



PRO SOUND

RCF offers modern sound reinforcement solutions for the market of professional users, consisting of innovative products that were engineered and manufactured to satisfy the needs of rental and production companies.

RDNet PRODUCTS

LINE ARRAY SYSTEMS

| | | |
|--------------------|------|----|
| HDL 50-A 4K | page | 8 |
| HDL 30-A | page | 10 |
| HDL 28-A | page | 12 |
| HDL 26-A | page | 14 |

SUBWOOFERS

| | | |
|--------------------|------|----|
| HDL 38-AS | page | 16 |
| HDL 36-AS | page | 18 |
| HDL 35-AS | page | 19 |
| HDM 45-A | page | 20 |
| SUB 9007-AS | page | 21 |
| SUB 9006-AS | page | 22 |
| SUB 9004-AS | page | 23 |

CONTROL

| | | |
|------------------|------|----|
| CONTROL 8 | page | 24 |
| CONTROL 2 | page | 25 |

LINE ARRAY SYSTEMS

| | | |
|---------------------|------|----|
| HDL 20-A | page | 26 |
| HDL 10-A | page | 28 |
| HDL 6-A | page | 30 |
| HDL 12-AS | page | 31 |
| NXL 44-A MK2 | page | 32 |
| NXL 24-A MK2 | page | 33 |

TWO-WAY SPEAKERS

| | | |
|-----------------|------|----|
| NX 45-A | page | 34 |
| NX 32-A | page | 35 |
| NX 915-A | page | 36 |
| NX 912-A | page | 36 |
| NX 910-A | page | 36 |

STAGE MONITORS

| | | |
|------------------|------|----|
| NX 15-SMA | page | 38 |
| NX 12-SMA | page | 38 |
| NX 10-SMA | page | 38 |
| ST 15-SMA | page | 39 |
| ST 12-SMA | page | 39 |

SUBWOOFERS

| | | |
|-----------------------|------|----|
| SUB 8006-AS | page | 40 |
| SUB 8004-AS | page | 41 |
| SUB 8003-AS II | page | 42 |
| SUB 905-AS II | page | 43 |

CONTROL & POWER

SUITABLE FOR ALL SYSTEMS

| | | |
|-----------------|------|----|
| DX 1616 | page | 44 |
| CR 16-ND | page | 45 |
| PR 63 | page | 45 |

CABLING, TRANSPORTATION AND ACCESSORIES

SUITABLE FOR ALL SYSTEMS

| | | |
|--------------------|------|----|
| ACCESSORIES | page | 46 |
|--------------------|------|----|

RCF Sound Culture

AT RCF WE CARE ABOUT YOUR SOUND

Since 1949 RCF has been committed to the perfect reproduction and amplification of sound in the fields of professional audio for events, music, broadcast and public address. We bring typical Italian passion for perfection and good design in the world of professional audio. RCF researches and develops every product from scratch, to ensure the maximum quality and reliability to the final user. The complete range of products covers all the aspects of the audio chain and all the requirements of musicians, sound engineers, architects and system integrators.



BASS MOTION CONTROL

When searching for an extended bass with enhanced performance, RCF engineers found a way to remove the high-pass filter, replacing it with a forward-thinking approach. Introducing BMC (Bass Motion Control), the newly advanced woofer excursion management feature. ART 9 with BMC can handle the lowest audible frequencies without affecting the woofer stability, with extended linearity and better sound integrity.

The BMC method works by creating a complete map of the dynamic behavior of the woofer, to generate a custom algorithm that only limits over-excursions. This gives total freedom of signal reproduction to the transducer. When high-pass filters normally protect the woofer motion from becoming destructive, but change the phase behavior, the new BMC algorithm breaks conventional rule. In combination with FIRPHASE technology, ART 9 has a level of DSP audio performance never achieved in this range of speakers.

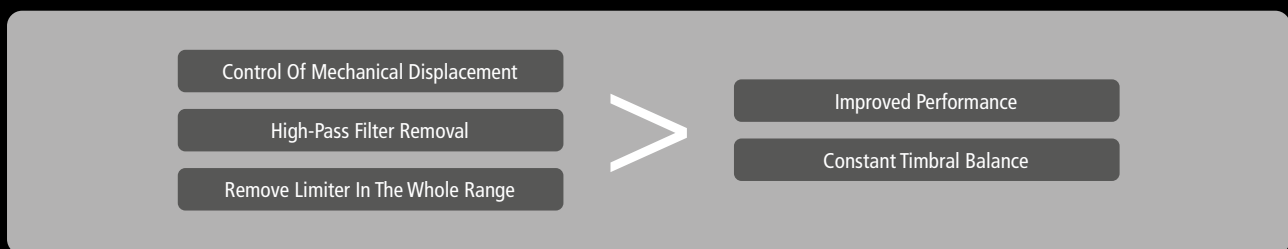

/ PRO SOUND

The concept behind our unique speaker design are derived from the touring industry, bringing in a versatile format all the experience of RCF professional sound engineers. The vocals are natural, the sound is clear at longer distances, and the SPL power is stable at very high levels. Perfect products for live sound reinforcement and reliable in various sound applications.

/ DSP

The new generation DSP handles all the processing within the cabinet and allows control of soft clipping limiters, RMS limits, amplitude and phase equalization. From the encoder on the input panel it is easy to adjust gain, low pass and high pass crossovers, delay, phase and cardioid equalization. Using the integrated RNet remote control you can monitor and adjust all settings.



FiRPHASE TECHNOLOGY

RCF speakers are designed using a proprietary and advanced FIR filtering technology, conceived to deliver transparent sound, absolute clarity and perfect stereo images to the listener. The special FiRPHASE filters allow for coherent distribution of sound for all listeners without phase distortions, ensuring minimum latencies in the system.

The design of the FIR filter for this specific purpose should start from an accurate measurement of the loudspeaker phase. FiRPHASE algorithm use this measurement and adapt the loudspeaker's phase without touching the amplitude equalization. The advanced technique used by FiRPHASE is a recursive method (least squares method) combined with a proprietary algorithm that calculates the best FIR filter coefficients according to amplitude and phase constrains. The algorithm corrects phase and amplitude (if necessary) by identifying the weak points of both the transducers and cabinet of the loudspeaker. This technique allows a deep control of phase at mid-low frequency with relatively small filters, while also achieving a higher resolution than that one as theory suggests.



/ TRANSDUCER INNOVATORS

RCF designs all the transducers to deliver a definite and clear sound, where the loudspeaker is able to reproduce a sound as close to the original as possible, while combining the absence of distortion. RCF develops advanced transducer technology including the application of high-tech materials and built to withstand high power levels over a long period of time.

/ RENTAL PROOF HARDWARE

The cabinets are made with the highest quality materials. From wood, plastics and metal parts to the final texture, RCF offers the maximum reliability and strength for the intensive use on the road in every product. The integrated mechanics allow the system engineer to create any configuration easily and safely.



NETWORKED SOUND SYSTEM MANAGER

RDNet is the RCF management software suite for Sound System Engineers. A robust management network for RCF devices, a line-array design tool, a monitoring platform, and a complete audio analyzer in one package. RDNet provides intuitive management of every connected device/object on the network. A network user can control all DSP settings inside any compatible device, including advanced subwoofer configurations, from a single object to a group of objects.

TOOLBOX FOR SOUND SYSTEM DESIGN

RDNet is more than just a speaker management software - you can control parameters and internal routings of multiple RCF devices, such as digital matrixes or amplifiers, both in live or installed applications. Featuring an advanced measurement suite and the ability to save/recall presets on the cloud, RDNet is the all-in-one solution for both touring and installed sound systems.

- Array and Zones Grouping
- Multiple-type EQ, Bass Shaper and FIRPHASE EQ
- Auto Scan and complete monitoring
- Shape Designer Array Calculator
- Real-time Measurement Suite
- Automatic Cluster Size shaping and Air Compensation
- Subwoofer configuration tool
- Cloud Storage

/ DOWNLOAD THE SOFTWARE



The RDNet software is available for free for registered users on RCF's website User's Area.

/ STRAIGHT-FORWARD SOUND DESIGN

Shape Designer prediction software enables a two-dimensional acoustic simulation of the array configuration and suggest LF Corrections based on the cluster size. The system curvature angles and sound projection data are computed with maximum sound pressure levels for the given design. The software provides system curvature and weight, system rigging points, and cabinet angles.



MONITOR AND MANAGE

The RDN Net Scan function sequentially scans all audio devices, recognizes, assigns digital address labels, and adds devices as objects in the main window. The real-time monitoring features a multitude of parameters such as fan speed, temperature, the inclination of a single speaker, VU Meters, peak levels and more. RDN Net takes direct control on the internal EQ and High-Pass filter on each cabinet.



GET THE MOST OF YOUR SYSTEM

RDN Net gives the ability to control devices in Groups for easy supervision. Arrays customizable Group properties are Zones, Air Compensation, Cluster Size, FIRPHASE Gain. When assigning Group Array objects in Zones: every Zone has its color for quick reference of set parameters. An incremental control shapes the Air Absorption Compensation, which can be very useful with changes in humidity or temperature (e.g., soundcheck on a sunny day, concert on a humid night). The line array's low-mid shaping is automatically calculated on the Cluster size to obtain the perfect linear frequency response from the entire system.

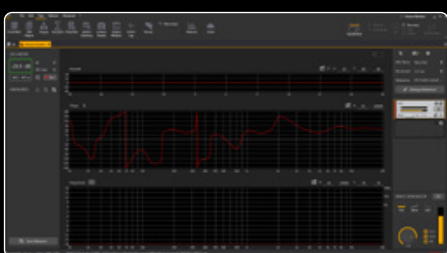

TAKE ALL APPROPRIATE MEASURES

RDN Net Measure is a powerful 4-input Dual-Channel FFT Audio Analyzer able to measure Magnitude, Phase, RTA, Coherence, and Impulse response. Functions included spans from a delay finder, a multiple signal generator, and an integrated SPL meter/logger with calibration tools. There's no need for external software to get the job done.



TRAVEL LIGHT ON CLOUDS

You don't need your personal computer anymore. Just connect your computer to the web, sign-in to your account, and you are ready to go with a complete set of audio tools for your RCF audio system. You can also save your projects and measurements and recall them anywhere you are.

/ NETWORKED SPEAKER CONTROL

When the RCF sound system is connected via Control2 or Control8 interfaces, the system engineer has complete control of time delay and equalization of all speakers, individually or grouped. With its built-in communication board and DSP, each device is an active part of the system, able to store presets, receive commands, and continuously send status information of single components or transducers. Comprehensive monitoring is standard in RDN Net: VU metering, clip indicator, limiter intervention, device inclination, communication issues, and much more.

/ EASY SUBWOOFER CONFIGURATION

Guided subwoofer configurations help the engineer to set up subwoofer Cardioids, Arcs, or EndFire configurations in one pass, while the Bass Shaper fine-tunes the desired timbre on low frequencies. With three sliders and a few steps, it's easy to correct low-end behavior while maintaining tonal balance across the entire system.

50

HDL 50-A 4K

ACTIVE THREE-WAY LINE ARRAY MODULE

The HDL 50-A 4K is an active 3-way line array module for large-sized events, indoors and outdoors. It features a sound pressure level of 143 dB SPL with a built-in 4000 W RMS Class-D four-channel amplifier. Equipped with eight best-of-class transducers, it offers excellent playback quality ideal for professional musical applications. The proprietary 90 x 10 degrees 4PATH waveguide with the symmetrical design of the cabinet delivers optimal coverage.

- 143 dB SPL Max
- 8000 W power, 4 x onboard amplifiers
- 40 ÷ 20000 Hz Frequency Range
- 90° x 10° wide, constant directivity coverage angle
- 2 x 3" neodymium Compression Drivers
- 4 x 6" neodymium Midrange
- 2 x 12" high power neodymium Woofer
- 200-800 Hz Crossover Frequency
- Wooden-reinforced polypropylene composite cabinet
- FiRPHASE Technology
- RDNet remote monitoring and control
- 366x1171x502 mm - 14.4x46.1x19.8 in (HxWxD)
- 58.4 kg - 128.75 lbs



/ CABINET

The HDL 50-A 4K tour-grade system comes in a composite wooden-polypropylene enclosure, and is equipped with two aluminum side handles with rubber handgrips and two rear handles for portability.

/ MAXIMUM EFFICIENCY

The HDL 50-A 4K is a true active high-power ready to use touring system. Equipped with a high-efficiency Class-D amplifier that delivers superior SPL, while reducing energy consumption. The integrated processing and cabling reduction makes the set-up fast and easy, while reducing space requirements during transport, due to its compact size.

/ FULLY INTEGRATED SYSTEM

The compact and lightweight design of the system combines with rugged steel mechanics for easy rigging and transportation.

/ CONFIGURABLE MECHANICS

The integrated mechanics are both fast and reconfigurable, allowing the system engineer to create J-shaped and spiral arrays with 0.5° resolution. The heavy-duty front grille is powder coated. A special transparent-to-sound foam backing inside helps to further protect the transducers from dust.

“ the most powerful
hdi array ever ”



INSIDE VIEW

/ LOW FREQUENCIES

- 2 X 3.0" v.c. neodymium 12" Woofers
- Water resistant fiber doped cone
- Polycotton M-roll surround
- Hypervented magnetic structure

/ MID FREQUENCIES

- 4 x 2.0" v.c. 6.0" neo Midranges
- Water resistant fiber doped cone
- Polycotton M-roll surround
- High power magnetic structure

/ HIGH FREQUENCIES

The two ND850 large format compression drivers deliver one of the key advantages of the HDL 50-A 4K. The 3.0" voice coil allows a crossover point of 800 Hz allowing the driver to produce almost all of the vocal range. This creates better coverage and superior efficiency.



4PATH WAVEGUIDE

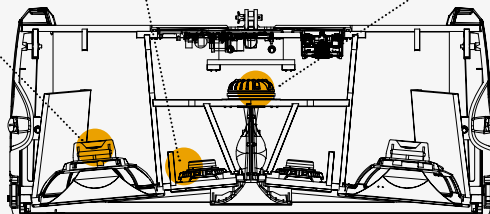

The custom 4PATH designed waveguide allows a precise coverage of 90 x 10 degrees, while also delivering a superb, linear high frequency response. The unique shape of the four ducts forming the guide creates an ideal isophasic load from 800 Hz to the highest audible frequencies.

/ V-SHAPED SYMMETRICAL DESIGN

The symmetrical design of the HDL 50-A 4K produces identical left and right coverage. The component positioning and special DSP crossover filtering of the cabinet takes care of the constant directivity without spots of break up or attenuation.

The originally designed V-SHAPED front baffle provides:

- Coplanar midranges and woofers
- Controlled LF dispersion
- Central space to host the HF guide.



p.n. 13000641 (90-240V)

30

HDL 30-A

ACTIVE TWO-WAY LINE ARRAY MODULE

The RCF HDL 30-A is a compact bi-amped 2-way active touring system for medium to large events, both indoors and outdoors. It features two 10-inch woofers and an impressive 4-inch titanium compression driver. The time coherent waveguide is the result of in-depth research and design. HDL 30-A is the first line array in a composite cabinet with zero-degree phase and ultra-linear amplitude response. The built-in 2200 Watt Class-D amplifier delivers excellent playback clarity and up to 137 dB SPL max. The RCF HDL 30-A features state-of-the-art RCF transducers with neodymium magnets. Considering its acoustical power, it has a remarkably low weight for easy handling and flying.



RCF's experienced engineering teams have developed and matched each component starting from the amplifier design, including a dedicated input board, from transducers right up to the complete HDL 30-A system. All HDL 30-A systems are hand-crafted by RCF.



/ RNet INSIDE

RNet Network Monitoring and Control, gives the system engineer the ability to carry out many system functions.

- 137 dB SPL Max
- 2200 W peak 2-way Class-D switching amplifier
- 50 ÷ 20000 Hz Frequency Range
- 100° x 15° wide, constant directivity coverage angle
- 1 x 4" neodymium Compression Drivers
- 2 x 10" high power neodymium Woofer
- 680 Hz Crossover Frequency
- FiRPHASE Technology
- RNet remote monitoring and control
- 293x705x502 mm - 11.5x27.7x19.7 in (HxWxD)
- 25 kg - 55.1 lbs

“ a lightweight champion with an impressive punch! ”

INSIDE VIEW

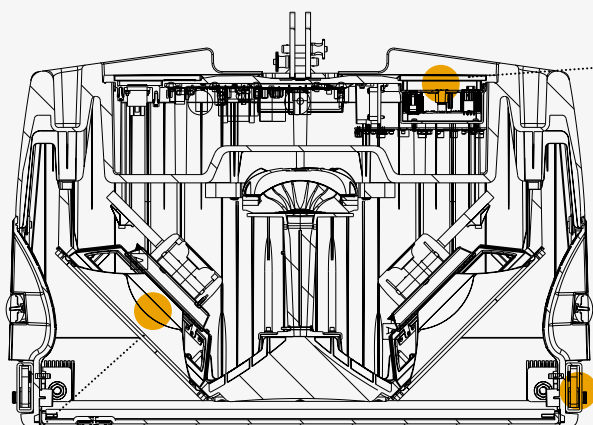

/ DSP

FIRPHASE filters allow coherent distribution of sound to be achieved for all listeners without phase distortion. Air Compensation for individual cabinets or groups helps to compensate the common frequency loss in air on long throw applications.

/ MECHANICS

High strength enclosure in composite polypropylene with a revolutionary new rigging concept inspired by its counter part: the RCF HDL 50-A 4K. Given its acoustical power, it has a remarkably low weight for easy handling and flying.

/ TRANSDUCERS

State of the art RCF transducers with neodymium magnets. Two 10" woofers and an impressive 4" titanium compression driver on a symmetrical design, for constant horizontal coverage.



p.n. 13000511 (90-240V)

/ MAIN FEATURES

- High Power / Low Weight
- Air Compensation
- Symmetrical acoustic design
- Easy to stack and fly

HDL 28-A

ACTIVE TWO-WAY LINE ARRAY MODULE

The RNet management network has been introduced to the new HDL 28-A. Because the woofer is a 2 x 8" device, with 2.5" voice coil and a 2200W Class-D amplifier, it is capable of far more bottom end for a wide range of applications, both indoors and outdoors, with an emphasis on vocal intelligibility. The proprietary 4 PATH waveguide paired with a 3-inch titanium compression driver creates precise coverage of 100 x 15 degrees and constant directivity without sign of break up or attenuation from 750 Hz. The symmetrical design of the cabinet delivers identical left and right coverage, FIRPHASE zero-degree phase processing, and ultra-linear amplitude response produce excellent playback clarity up to 135 decibel SPL max. The RCF HDL 28-A features state-of-the-art RCF transducers with lightweight neodymium magnets on a composite material cabinet, providing remarkably low weight for easy handling and flying.



/ THE ACOUSTIC BEAUTY OF THE SYMMETRY

The symmetrical design of the cabinet produces identical left and right coverage. The component positioning and special DSP crossover filtering of the HDL 28-A take care of the constant directivity without spots of break up or attenuation. The specially-designed front baffle provides coplanar woofers, controlled LF dispersion and a central space to host the 4PATH waveguide. The heavy-duty front grille is powder coated with a special transparent-to-sound foam backing inside helps to further protect the transducers from dust. A rain cover is also available.

ADVANTAGES

- High Power / Low Weight
- Symmetrical acoustic design
- Emphasis on vocal intelligibility
- Easy to stack and fly

- 135 dB SPL Max
- 2200 W peak 2-way Class-D switching amplifier
- 50 ÷ 20000 Hz Frequency Range
- 100° x 15° wide, constant directivity coverage angle
- 3.0" diaphragm titanium compression driver
- 2 x 8" high power neodymium Woofer
- 750 Hz Crossover Frequency
- FIRPHASE Technology
- RNet remote monitoring and control
- 294x569x491 mm - 11.57x22.4x19.33 in (HxWxD)
- 20.6 kg - 46.3 lbs

“ superior
vocal clarity ”



/ FIRST CLASS TRANSDUCERS

INSIDE VIEW

The RCF HDL 28-A features state-of-the-art RCF transducers with neodymium magnets. RCF's experienced engineering teams have specially developed and matched each component — starting from the power supply through the input board, to the amplifiers and transducers, right up to the complete HDL 28-A System.

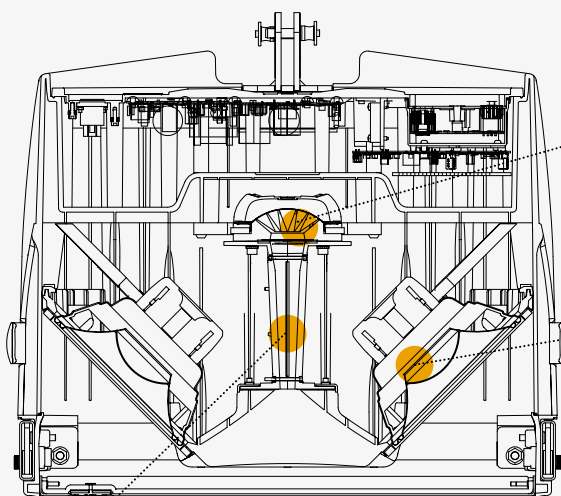

/ HIGH FREQUENCIES

- High-performance RCF ND840
- 3.0-inch diaphragm titanium compression Driver
- 1.4-inch exit throat
- 750 Hz Crossover Point

/ LOW FREQUENCIES

- 2 X 2.5" voice coil neodymium 8" Woofers
- Linear low frequencies handling down to 65 Hz
- Water resistant fiber doped cone
- Polycotton M-roll surround
- Vented magnetic structure

The custom 4 PATH-designed waveguide allows precise coverage of 100 x 15 degrees, while also delivering an excellent, linear high-frequency response. The unique shape of the four ducts forming the guide creates an ideal isophasic load from 750 Hz to the highest audible frequencies.



p.n. 13000605 (90-240V) WHITE



p.n. 13000579 (90-240V) BLACK



/ FLYING ATTITUDE

The advanced rigging concept derives directly from its big brothers: the RCF HDL 30-A and HDL 50-A 4K. The integrated mechanics are both fast and reconfigurable, allowing the system engineer to create J-shapes and spiral arrays. The hardware is designed for easy and fast setup. The angle can be adjusted on the ground before the system is hung and slipped automatically into the correct position as the array is pulled up. Up to 20 HDL 28-A modules can be fastened on a single flybar.

HDL 26-A

ACTIVE TWO-WAY LINE ARRAY MODULE

The RCF HDL 26-A is an ultra-compact bi-amped 2-way active touring system for small and medium-sized events, both indoors and outdoors. Because of the advanced transducers' design and the 2000W Class-D amplifier, among the best in its class, it is capable of extended bottom end and a pristine sound for a wide range of applications, alone or in a line-array configuration. It features two 6-inch woofers and an impressive 3-inch titanium compression driver. Following the HDL 30-A philosophy, the HDL 26-A shares the RDNet management network, the composite material cabinet, the zero-degree phase, and ultra-linear amplitude response. The proprietary 4PATH waveguide and the impressive 3-inch titanium compression driver create a precise coverage of 100 x 10 degrees and constant directivity without break up or attenuation from 750 Hz. The symmetrical design of the cabinet delivers identical left and right coverage producing excellent playback clarity up to 133 decibel SPL max.

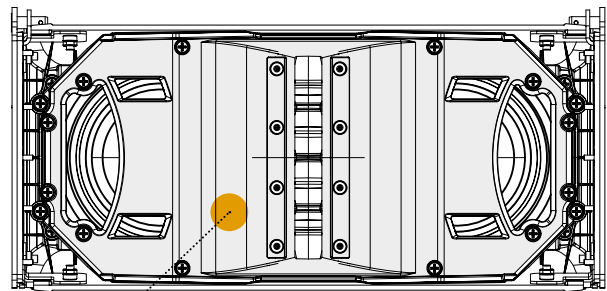

The frontal baffle's design increases the directivity of the line array doubling the radiation points on low/mid frequencies. The shape of the front baffle reduces the turbulence outside the waveguide decreasing the overall distortion.



/ CABINET & MECHANICS

The hardware is designed for an easy and fast setup. The angle can be adjusted on the ground before hand, and slip automatically into the correct position when pulling up the array. Up to 16 HDL 26-A modules can be fastened on a single flybar. The heavy-duty front grille is powder coated. A special transparent-to-sound foam backing inside helps to further protect the transducers from dust. A rain cover is also available.

- 133 dB SPL Max
- 2000 W peak 2-way Class-D switching amplifier
- 55 ÷ 20000 Hz Frequency Range
- 100° x 10° wide, constant directivity coverage angle
- 1.4" Titanium Compression Driver, 3.0" voice coil
- 2 x 6" Neodymium Woofers, 2.0" voice coil
- 750 Hz Crossover Frequency
- FiRPHASE Technology
- RDNet remote monitoring and control
- 237x470x377 mm - 9.33x18.5x14.84 in (HxWxD)
- 13.5 kg - 29.76 lbs

“*ultra-compact
rcf technology*”



INSIDE VIEW

/ FIRST CLASS TRANSDUCERS

The RCF HDL 26-A features state-of-the-art RCF transducers with neodymium magnets. RCF's experienced engineering teams have specially developed and matched each component — starting from the power supply through the input board, to the amplifiers and transducers, right up to the complete HDL 26-A System.



The custom designed 4 PATH waveguide allows a precise coverage of 100 x 10 degrees, while also delivering an excellent, linear high-frequency response. The unique shape of the four ducts forming the guide creates an ideal isophasic load from 750 Hz to the highest audible frequencies.

/ HIGH FREQUENCIES

- 3.0-inch diaphragm titanium compression Driver
- 1.4-inch exit throat
- 750 Hz Crossover Point

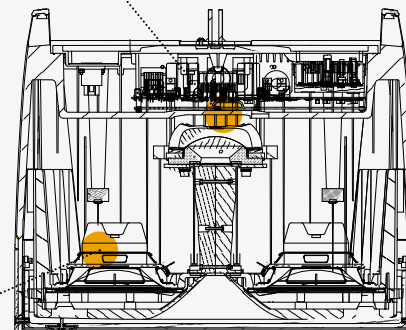

/ LOW FREQUENCIES 6" WOOFERS

- 2 X 2.0" voice coil neodymium 6" Woofers
- Low frequencies handling down to 65 Hz
- Water resistant fibre doped cone
- Polycotton M-roll surround



p.n. 13000606 (90-240V) WHITE



p.n. 13000588 (90-240V) BLACK

SYMMETRICAL DESIGN

The symmetrical design of the cabinet produces identical left and right coverage of 100°x10°. The component positioning and special DSP crossover filtering of the HDL 26-A take care of the constant directivity without spots of break up or attenuation. The front baffle provides: Coplanar woofers - Controlled LF dispersion - Central space to host the HF waveguide

HDL FLYABLE SUBWOOFERS

HDL 38-AS

ACTIVE FLYABLE SUBWOOFER MODULE FOR THE HDL 30-A

The HDL 38-AS is the ideal flyable bass complement for the HDL 30-A array system. It features one 4.0" voice coil, 18" Neodymium woofer to handle 136 dB SPL Max from 30 Hz to 140 Hz with maximum linearity and low distortion. The HDL 38-AS is perfect to create flown systems for theatrical and indoor venues. The built-in 3200 W Class-D amplifier delivers excellent playback clarity and up to 136 decibels SPL max. With RNet compatibility, the HDL 38-AS is part of the professional HDL System.



/ POWERFUL CLASS-D AMPLIFIERS

RCF's Class-D power amplifier technology packs high efficiency into a lightweight solution. HDL amplifiers deliver a ultra-fast attack, realistic transient response, and impressive audio performance. The amplifier features a solid machined aluminium

structure which not only stabilizes the amplifier during transportation but also helps with heat dissipation. All the HDL amplifiers present SMPS power supply section to produce maximum output and minimum weight. The HDL 38-AS incorporates the RNet Network Management System.

/ CABINET AND MECHANICS

The hardware is designed for an easy and fast setup, completely compatible with the HDL 30-A rigging. The heavy-duty front grille is powder coated. A special transparent-to-sound foam backing inside helps to further protect the transducers from dust. For weatherproof capabilities, a rain cover is available.



- 136 dB SPL Max
- 3200 W Class-D Amplifier
- 30 ÷ 140 Hz Frequency Range
- 18" Neodymium Woofer, 4.0" voice coil
- RNet remote monitoring and control
- 502x700x621 mm
19.76x27.56x24.45 in (HxWxD)
- 48.7 kg - 107.35 lbs

p.n. 13000580 (90-240 V)



/ ADVANCED PROCESSING

A 32-bit floating-point DSP processing manages:

- System's crossover and transducers' alignment
- Programmable system's equalization
- Input sensitivity reduction
- Soft limiter and gentle compressor for high signal inputs
- RMS current monitoring and transducer protection

A specially developed algorithm takes care of the frequency-dependent soft limiter, offering the listener the same system linearity, from very low-level signals to the maximum amplifier output.

/ MAIN FEATURES

- High Power
- Easy to stack and fly
- Emphasis on playback clarity



/ 18" PRECISION TRANSDUCER

Our latest developments have resulted in designing state-of-the-art neodymium magnetic circuits, radically new voice coil ventilation systems and ground breaking direct drive voice coil assemblies.



HDL FLYABLE SUBWOOFERS

HDL 36-AS

ACTIVE FLYABLE SUBWOOFER MODULE FOR THE HDL 28-A

Theatrical and indoor requirements often need space in front of the stage, leaving no space for subwoofers. The HDL 36-AS is the ideal flyable bass complement for the HDL 28-A array system. It features one 4.0" voice coil, 15" Neodymium woofer to handle 135 dB SPL Max from 40 Hz to 140 Hz with maximum linearity and low distortion. The built-in 3200 Watt Class-D amplifier delivers excellent playback clarity and up to 135 decibels SPL max. With RDNet compatibility, the HDL 36-AS is part of the professional HDL System.

/ LEGENDARY WOOFERS

RCF subwoofers are the first choice of many sound engineers, due to the very high SPL levels at very low frequencies, smaller dimensions compared to the competitors, self-powered design, RDNet remote control, cardioid configuration options and impressive size/weight to SPL output ratio. Your audience will enjoy an engaging immersive experience.

/ POWERFUL CLASS D AMPLIFIERS

RCF's Class-D power amplifier technology packs with high-efficiency into a lightweight solution. HDL amplifiers deliver a ultra-fast attack, realistic transient response, and impressive audio performance. The amplifier features a solid machined aluminium structure which not only stabilizes the amplifier during transportation but also helps the fan-less heat dissipation. All the HDL amplifiers present SMPS power supply section to produce maximum output and minimum weight.



The hardware is designed for an easy and fast setup, completely compatible with HDL 28-A rigging. The heavy-duty front grille is powder coated. A special transparent-to-sound foam backing inside helps to further protect the transducers from dust. A rain cover is also available.



p.n. 13000583 (90 V - 240 V)

- 135 dB Max SPL
- 3200 W Amplifier
- 40 ÷ 140 Hz frequency response
- 15" Neodymium Woofer, 4.0" voice coil
- RDNet remote monitoring and control
- 458x569x592 mm - 18x22.4x23.31 in (HxWxD)
- 37 kg - 81.57 lbs



HDL 35-AS

ACTIVE FLYABLE SUBWOOFER MODULE FOR THE HDL 26-A

While the HDL 26-A is designed for the best speech intelligibility and background music, a correct musical response requires low distortion and high power on low frequencies. The HDL 35-AS is the ideal flyable bass complement for the HDL 26-A array system. It features a baltic birch plywood cabinet housing one 4.0" voice coil, 15" Neodymium woofer to handle frequencies from 40 Hz to 140 Hz with the maximum linearity and lowest distortion.

The hardware is designed for an easy and fast setup, completely compatible with HDL 26-A rigging. The heavy-duty front grille is powder coated. A special transparent-to-sound foam backing inside helps to further protect the transducers from dust. A rain cover is also available.

/ PRECISION TRANSDUCERS

Our latest developments have resulted in designing state-of-the-art neodymium magnetic circuits, radically new voice coil ventilation systems and ground breaking direct drive voice coil assemblies.



/ POWERFUL CLASS D AMPLIFIER

RCF's Class-D power amplifier technology packs with high-efficiency into a lightweight solution. HDL amplifiers deliver a ultra-fast attack, realistic transient response, and impressive audio performance.

The amplifier features a solid machined aluminium structure which not only stabilizes the amplifier during transportation but also helps the fan-less heat dissipation. All the HDL amplifiers present SMPS power supply section to produce maximum output and minimum weight.



- 134 dB Max SPL
- 2200 W Amplifier
- 40 ÷ 140 Hz frequency response
- 1x15" Neodymium Woofer, 4.0" voice coil
- RDNet remote monitoring and control
- 444x456x508 mm - 17.48x17.95x20 in (HxWxD)
- 30 kg - 66.14 lbs

p.n. 13000575 (90-240V) BLACK - p.n. 13000664 (90-240V) WHITE

45

TWO-WAY SPEAKER

HDM 45-A

ACTIVE TWO-WAY SPEAKER

The HDM 45-A speaker boosts the performance with a top-quality two channel amplifier, RDNet management network ports, RCF precision transducers, FIRPHASE processing, and a rugged cabinet built for professionals. While it is one of the most powerful speaker in composite material in its category, it delivers clear, detailed and smooth sound from low to very high levels, with low distortion and fast transient response. The HDM concept is inspired by the touring industry, bringing in an elegant and lightweight cabinet all with the maximum reliability and strength for the intensive use on the road. Perfect as a main front of house in PA systems, high-powered floor monitor, or unobtrusive infill system when combined with the RCF HDL System speakers.

/ RENTAL PROOF

D LINE cabinets are molded with a special polypropylene composite material designed to dampen vibrations even at maximum volume settings. From molding to the final texture, D-LINE offers maximum reliability and strength for intensive use on the road. The advanced vented architecture offer high efficiency and low distortion. The speaker is equipped with a top handle and two side handles with rubber handgrips for greater portability.

/ SUPERIOR COMPRESSION DRIVER

The ND940 Compression Driver in pure Titanium with a 4 inches voice coil allows a crossover point at only 650 Hz. This allows a better impulse response, fast decay and superior efficiency. Lightweight and powerful, RCF neodymium drivers are a reference in performance and reliability.

/ POTENT WOOFER

The low-frequency transducer is a high-power 15" neodymium woofer with a 3.5" voice coil, delivering a punchy bass. Reproduction of the mid-bass frequencies is accurate, transparent and free from distortion.

/ STATE-OF-THE-ART POWER

Two independent Class-D amplifiers – 1600 W low frequencies, 600 W for the high frequency driver – deliver an astonishing output power making the HDM 45-A the most powerful speaker in composite material in its category. The input section provides In/Out XLR connectors, central encoder to control system parameters, and RDNet Input and Output.



p.n. 13000593 (90-240V)

- 133 dB Max SPL
- 2200 W 2-way power
- 1.5" Titanium Compression Driver, 4.0" v.c. Neodymium
- 15" Neodymium Woofer, 3.5" v.c. Neodymium
- 650 Hz crossover point for perfect vocal reproduction
- 90°x60°, wide dispersion constant directivity horn
- RDNet remote monitoring and control
- FIRPHASE Technology
- 714x442x397 mm - 28.11x17.40x15.63 in (HxWxD)
- 22 kg - 48.5 lbs

SUBWOOFERS

SUB 9007-AS

ACTIVE HIGH POWER SUBWOOFER

The SUB 9007-AS is one of the most powerful 2x21" subwoofers in the field of live sound. Featuring two, high-power, hyper-vented 21" neodymium woofers with 4.0" inside-outside voice coils, this cabinet delivers serious low frequencies. Powered by a 7200W digital amplifier, the SUB 9007-AS can perform in the most demanding situations. The housing of the SUB 9007-AS matches the RCF D-Line HDL 50-A and HD L20-A array systems, enabling stacked systems to match in a perfect combination.

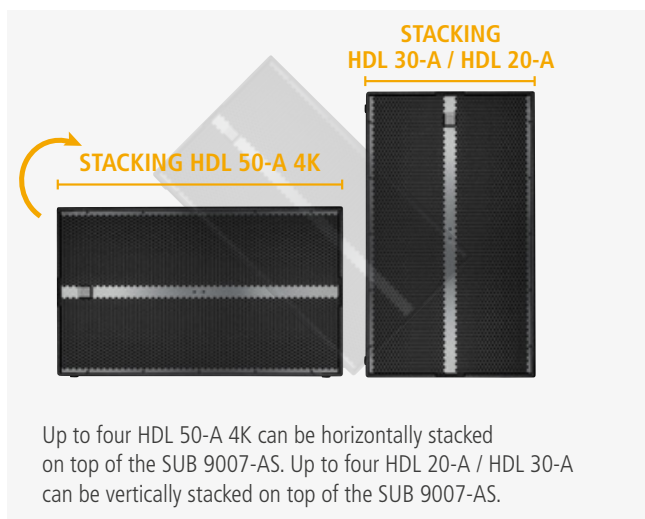

/ HYPERVENTED HIGH POWER NEODYMIUM WOOFERS

Custom designed 21" transducers joins the ultimate power performance to the incredibly lightweight. RCF designs these components to deliver the cleanest, punchiest and undistorted low frequencies for the best sound reproduction. In order to dissipate the heat generated by the powerful 4.0" voice coil, RCF engineers have developed a unique ventilation system that offers the best thermal dissipation and the lowest power compression. The Hyper Ventilation System is the result of a complex combination of ventilation ducts in the voice coil former, in the magnetic structure and in the woofer basket.

/ INDEPENDENT AMPLIFICATION CHANNELS

Two separate Class-D amplifiers ensure top efficiency and maximum reliability for an extensive use of the subwoofer during tours. Each amplifier delivers 3600 W to the 21" woofers and the regulated power supply guarantees full power from 100 V to 260 V. The amplifier is housed on a unique Vibrostop floating aluminum panel for extra protection during transportation.

/ DSP PROCESSING

A new generation DSP handles all the processing within the cabinet and allows control of soft clipping limiters, RMS limits, amplitude and phase equalization. From the encoder on the input panel users can adjust gain, low pass and high pass crossovers, delay, polarity and cardioid equalization. Users can access these settings via integrated RDNNet remote control.

- 141 dB SPL Max
- 7200 W
- 20 ÷ 400 Hz Frequency Range
- 2 x 21" Hyper Ventilation neodymium Subwoofer
- DSP Controlled Input Section with selectable presets
- RDNNet remote monitoring and control
- Delay Control
- 708x1188x785 mm - 27.87x46.77x30.91 in (HxWxD)
- 96 kg - 211.64 lbs



p.n. 13000493 (90-240 V)

SUBWOOFERS

SUB 9006-AS

ACTIVE HIGH POWER SUBWOOFER

The SUB 9006-AS has been designed to render effortless low frequency transients with a very fast response. As a self-powered system, the transducers, amplification and DSP control electronics of the SUB 9006-AS are designed to optimize performance and maximize power. The SUB 9006-AS's low tuned cabinet houses two RCF Precision new back-vented long-excursion high-power 18" inch cone drivers, providing a fast and controlled reproduction of the bass frequency range. It features a four-layer 4" inside/outside voice coil to minimize power compression and extend the life of this product.

/ HEAVY DUTY CABINET

The cabinet is made of high-quality birch plywood with every layer glued with a special water resistant adhesive that makes the cabinet weatherproof. The heavy-duty front grille integrates a central reinforcement bar and is powder coated. The SUB 9006-AS is equipped with 8 aluminum handles (4 per side) with ergonomic rubber handgrip and can be equipped with transportation front cart.

/ TWO INDEPENDENT CHANNELS

Two separate Class-D amplifiers ensure top efficiency levels and maximum reliability for an extensive use of the subwoofer during tours. Each amplifier delivers 3600W to the 18" woofers and the regulated power supply guarantees full power from 100V to 260V.

/ TRANSPORTATION CART

The front of the cabinet integrates two locking points to insert and fix the detachable Kart kit: a dolly caster-board with rugged four grade swivel wheels with brakes. It features a wood protection cover designed to protect the subwoofer grille during transportation. The accessory is made in strong plywood finished with a scratch-resistant paint.

CUSTOM HIGH POWER NEODYMIUM WOOFERS

The new custom designed 18" transducers join the ultimate power performance to an incredible light weight. RCF manufacture these components to deliver the cleanest, punchiest and undistorted low frequencies reproduction. In order to dissipate the heat generated by the powerful 4.0" voice coil, RCF engineers have developed a unique ventilation system that offers the best thermal dissipation and the lowest power compression.

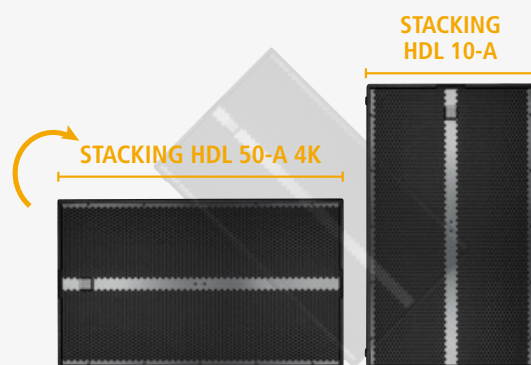

Up to four HDL 50-A 4K can be horizontally stacked on top of the SUB 9006-AS. Up to four HDL 10-A can be vertically stacked on top of the SUB 9006-AS.



p.n. 13000494 (90-240 V)

- 142 dB SPL Max
- 7200 W
- 30 ÷ 400 Hz Frequency Range
- 2 x 18" Hyper Ventilation neodymium Subwoofer
- DSP Controlled Input Section with selectable presets
- RDNet remote monitoring and control
- Delay Control
- Baltic Birch tour grade cabinet
- 558x1188x785 mm - 22.0x46.8x30.9 in (HxWxD)
- 86 kg - 189.59 lbs



SUB 9004-AS

ACTIVE HIGH POWER SUBWOOFER

The SUB 9004-AS is a single 18" high power active subwoofer. It employs a state-of-the-art transducer featuring a hypervented high power neodymium magnetic circuit with 4" voice coil. The extremely high-power amplifier is a new design that delivers extended low frequency performance. Ruggedly-designed, is perfect for AV rental companies.

STACKING HDL 30-A, HDL 28-A OR HDL 10-A

Up to four HDL 30-A can be horizontally stacked on top of the SUB 9004-AS.

Up to four HDL 10-A / HDL 28-A can be vertically stacked on top of the SUB 9004-AS.

HDL 10-A
HDL 28-A HDL 30-A



Sophisticated DSP is at the core of a fully-featured input section, providing user selectable cross-over functionality, polarity optimization, protection, dynamic limiting and discrete component optimization.

INSIDE VIEW

/ PLYWOOD CABINET

The cabinet is made of high-quality birch plywood. Every layer is glued with a special water resistant adhesive that makes the cabinet weatherproof. The subs are stackable and light-weight, for easy set-up and tear down. A pole receptacle on top and side allows the woofer to be deployed in various configurations.

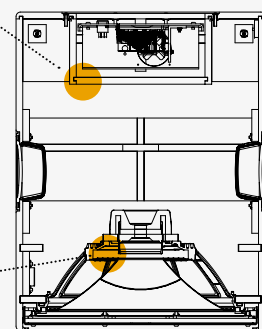

/ HYPERVENTED HIGH-POWER NEODYMIUM WOOFER

The new custom-designed 18" transducer combines power and performance with an incredibly light weight enclosure. In order to dissipate the heat generated by the powerful 4.0" voice coil, RCF engineers have developed a unique ventilation system that offers the best thermal dissipation and the lowest power compression.



- 136 dB SPL Max
- 2800 W power rating
- 30 ÷ 400 Hz Frequency Range
- 1 x 18" Hyper Ventilation Neodymium Subwoofer
- DSP Controlled Input Section with selectable presets
- RNet remote monitoring and control
- Delay Control
- Baltic Birch Cabinet
- 700x558x700 mm - 27.56x21.97x27.56 in (HxWxD)
- 57 kg - 125.6 lbs

p.n. 13000546 (90-240 V)

CONTROL

CONTROL 8

8 OUTPUT Ethernet/USB MASTER UNIT

The RNet Control 8 is a real-time monitor and control system able to manage up to 256 devices linked 32 per bus on 8 buses. All data is collected from the slaves and delivered to the sound engineer by USB in a local installation or by Ethernet from remote locations. The interface can be directly connected to the DSP on board of HDL products through the exclusive RNet protocol to address single cabinets or groups, specific presets or modification parameters in real-time. RNet software supports up to 20 CONTROL 8, all simultaneously linked to a computer via Ethernet, to get up to 160 RNet ports (up to 5120 devices).



/ CONTROL FLEXIBILITY

The PC cyclically requires the RNet Control 8 unit the operating state of audio devices that make up the communication network. All data is collected by the central unit that performs a sequential scan of all audio devices. Digital address allocation is automatic. It is possible to check each single audio device and edit its parameters (e.g. output level, mute, equalization, delay, etc.) by using the PC software. The audio device overall configuration can be saved as file in the PC and later reloaded. It is possible to synchronize all parameter values of the RNet Control 8 unit to the ones of the PC software preset.



/ COMMUNICATION FLEXIBILITY

The link between the PC and the RNet Control 8 unit can be made through USB port or Ethernet port.



/ TOPOLOGY FLEXIBILITY

The RNet Control 8 unit can manage up to 8 subnets. Up to 32 audio devices can be connected to each subnet (8 subnets x 32 = total 256 audio devices).



p.n. 17170154

- RNet control and monitoring in a single device by Ethernet or USB
- Up to 8 subnet of up to 32 slaves devices
- Automatic network configuration and registration
- Slave devices status and functions real time control
- Monitoring and display of faults and warnings
- User configurations storage and recall

“ control 8 manages up to 256 devices ”



CONTROL 2

2 OUTPUT USB MASTER UNIT

The RDNet Control 2 is a hardware interface that connects RCF RDNet compatible devices to a Personal Computer (PC) via a USB connection. The RDNet system was developed to create a data network for monitoring and command of more systems. The RDNet Control 2 unit can manage up to 2 subnets. Up to 32 devices can be connected to each subnet (2 subnets x 32 = total 64 devices). By addressing the various devices is handled automatically by RDNet Control 2 interface, each device is assigned a unique address during the power on procedure of network.



| ID | Description | Channel | Line | Gain | Equal | Delay | Phase | Pre | Post | Master | Slave | Equalizer | Cluster Size | IP Connection | Band | Level | Control | Angle |
|----|-------------|---------|----------|------|-------|-------|-------|-----|------|--------|-------|-----------|--------------|---------------|------|-------|---------|-------|
| 1 | TR150A | 1 | Line 1 1 | 0 | 0 | 0 | 0 | 111 | 0 | 0 | 0 | 0 | 1 | 1 KHz | ... | ... | ... | ... |
| 2 | TR150A | 1 | Line 1 2 | 0 | 0 | 0 | 0 | 111 | 0 | 0 | 0 | 0 | 1 | 1 KHz | ... | ... | ... | ... |
| 3 | TR150A | 1 | Line 1 3 | 0 | 0 | 0 | 0 | 111 | 0 | 0 | 0 | 0 | 1 | 1 KHz | ... | ... | ... | ... |
| 4 | TR150A | 1 | Line 1 4 | 0 | 0 | 0 | 0 | 111 | 0 | 0 | 0 | 0 | 1 | 1 KHz | ... | ... | ... | ... |
| 5 | TR150A | 1 | Line 1 5 | 0 | 0 | 0 | 0 | 111 | 0 | 0 | 0 | 0 | 1 | 1 KHz | ... | ... | ... | ... |
| 6 | TR150A | 1 | Line 1 6 | 0 | 0 | 0 | 0 | 111 | 0 | 0 | 0 | 0 | 1 | 1 KHz | ... | ... | ... | ... |
| 7 | TR150A | 1 | Line 1 7 | 0 | 0 | 0 | 0 | 111 | 0 | 0 | 0 | 0 | 1 | 1 KHz | ... | ... | ... | ... |
| 8 | TR150A | 1 | Line 1 8 | 0 | 0 | 0 | 0 | 111 | 0 | 0 | 0 | 0 | 1 | 1 KHz | ... | ... | ... | ... |
| 9 | TR150A | 1 | Line 2 1 | 0 | 0 | 0 | 0 | 111 | 0 | 0 | 0 | 0 | 1 | 1 KHz | ... | ... | ... | ... |
| 10 | TR150A | 1 | Line 2 2 | 0 | 0 | 0 | 0 | 111 | 0 | 0 | 0 | 0 | 1 | 1 KHz | ... | ... | ... | ... |
| 11 | TR150A | 1 | Line 2 3 | 0 | 0 | 0 | 0 | 111 | 0 | 0 | 0 | 0 | 1 | 1 KHz | ... | ... | ... | ... |
| 12 | TR150A | 1 | Line 2 4 | 0 | 0 | 0 | 0 | 111 | 0 | 0 | 0 | 0 | 1 | 1 KHz | ... | ... | ... | ... |
| 13 | TR150A | 1 | Line 2 5 | 0 | 0 | 0 | 0 | 111 | 0 | 0 | 0 | 0 | 1 | 1 KHz | ... | ... | ... | ... |
| 14 | TR150A | 1 | Line 2 6 | 0 | 0 | 0 | 0 | 111 | 0 | 0 | 0 | 0 | 1 | 1 KHz | ... | ... | ... | ... |
| 15 | TR150A | 1 | Line 2 7 | 0 | 0 | 0 | 0 | 111 | 0 | 0 | 0 | 0 | 1 | 1 KHz | ... | ... | ... | ... |
| 16 | TR150A | 1 | Line 2 8 | 0 | 0 | 0 | 0 | 111 | 0 | 0 | 0 | 0 | 1 | 1 KHz | ... | ... | ... | ... |
| 17 | TR150A | 1 | Line 3 1 | 0 | 0 | 0 | 0 | 111 | 0 | 0 | 0 | 0 | 1 | 1 KHz | ... | ... | ... | ... |
| 18 | TR150A | 1 | Line 3 2 | 0 | 0 | 0 | 0 | 111 | 0 | 0 | 0 | 0 | 1 | 1 KHz | ... | ... | ... | ... |
| 19 | TR150A | 1 | Line 3 3 | 0 | 0 | 0 | 0 | 111 | 0 | 0 | 0 | 0 | 1 | 1 KHz | ... | ... | ... | ... |
| 20 | TR150A | 1 | Line 3 4 | 0 | 0 | 0 | 0 | 111 | 0 | 0 | 0 | 0 | 1 | 1 KHz | ... | ... | ... | ... |
| 21 | TR150A | 1 | Line 3 5 | 0 | 0 | 0 | 0 | 111 | 0 | 0 | 0 | 0 | 1 | 1 KHz | ... | ... | ... | ... |
| 22 | TR150A | 1 | Line 3 6 | 0 | 0 | 0 | 0 | 111 | 0 | 0 | 0 | 0 | 1 | 1 KHz | ... | ... | ... | ... |
| 23 | TR150A | 1 | Line 3 7 | 0 | 0 | 0 | 0 | 111 | 0 | 0 | 0 | 0 | 1 | 1 KHz | ... | ... | ... | ... |
| 24 | TR150A | 1 | Line 3 8 | 0 | 0 | 0 | 0 | 111 | 0 | 0 | 0 | 0 | 1 | 1 KHz | ... | ... | ... | ... |

THE BENEFITS OF RDNet

Using our proprietary RDNet protocol users can monitor all system parameters, from the input to the status of each single amplifier. Having a DSP on board each cabinet, users can also address single cabinets or groups of cabinets' specific presets or modifications of parameters like gain, equalization or delay. The RDNet protocol is based on a stable, RS-485 communication protocol, and can send and receive data on a simple XLR cable.



p.n. 17170163 (USB POWERED)

- RDNet control and monitoring in a single device by USB communication
- Up to 2 subnet of up to 32 slaves devices
- Automatic network configuration and registration
- Slave devices status and functions real time control
- Monitoring and display of faults and warnings sent from slave devices
- User configurations storage and recall

“ full control from a pocket size device ”

HDL 20-A

ACTIVE TWO-WAY LINE ARRAY MODULE

The careful acoustic research, no compromise transducers and a unique, composite cabinet design, make the HDL 20-A the preferred audio tool of many professionals. Perfect in live sound reinforcement and reliable installed situations.

The HDL 20-A is the ideal choice when line array performance is needed and a fast and easy set up is a must. The system is powered from a 1400 Watt Peak Power 2-way digital amplifier, sound is processed from a powerful DSP. The processing includes cluster and HF projection correction and special new presets for indoor and high curving situations. The system features state-of-the-art RCF transducers, two powerful 10" for a solid bass reproduction and a large format 3" voice coil compression driver to deliver vocal clarity and high definition with incredible dynamics.

- 135 dB max SPL
- 1400 W two-way Class-D switching amplifier
- 55 ÷ 20000 Hz Frequency Range
- 100° x 15° wide, constant directivity coverage angle
- 3.0" voice coil c. driver
- 2 x high power 10" Woofers
- 48 kHz, 32 bit DSP processing
- Symmetrical design
- 294x705x445 mm - 11.5x27.7x17.5 in (HxWxD)
- Extremely low weight 30.2 kg - 66.58 lbs



p.n. 13040007 (220-240V) - 13040008 (115V)



INSIDE VIEW

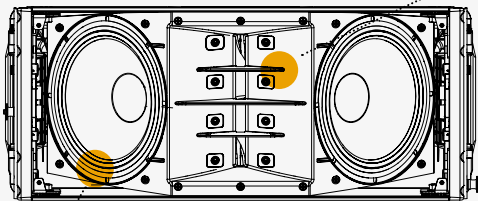

/ LOW FREQUENCIES 10" WOOFERS

- 2,5" Inside-Outside voice coil
- Water resistant fibre doped cone
- Polycotton M-roll surround
- High-power magnetic structure

/ HIGH FREQUENCIES

The CD 850 large format compression driver delivers one of the key advantages of the HDL 20-A. The 3" voice coil allows a crossover point of 800Hz and therefore almost all of the vocal range can be produced by this driver. This allows better coverage and dispersion control and superior efficiency.



The custom designed waveguide allows a precise coverage of 100 x 15 degrees, while also delivering a superb, linear high-frequency response.



DSP PROCESSING

The HDL 20-A is powered by a 1400W peak power two-way digital amplifier. A new generation DSP handles all the processing within the cabinet and allows adjustment of cluster size and HF projection. The DSP also includes presets for indoor/outdoor usage and highly curved arrays.

10

HDL 10-A

ACTIVE TWO-WAY LINE ARRAY MODULE

The very compact size, no compromise transducers and a unique composite cabinet design make the HDL 10-A the perfect audio tool in many situations. Ideal for live sound reinforcement and reliable installed applications, the HDL 10-A is an excellent choice when line array performance is needed and a fast and easy set up is a must. The system is powered by a 1400 Watt Peak Power 2-way digital amplifier, sound is processed with a powerful DSP.

- 133 dB max SPL
- 1400 W two-way Class-D switching amplifier
- 65 ÷ 20000 Hz Frequency Range
- 100° x 15° wide, constant directivity coverage angle
- 2.5" voice coil c. driver
- 2 x high power 8.0" Woofers
- 48 kHz, 32 bit DSP processing
- Symmetrical design
- 294x569x434 mm - 11.5x22.4x17.0 in (HxWxD)
- Extremely low weight 20.4 kg - 44.97 lbs



p.n. 13040016 (220-240V) - 13040017(115V) BLACK



p.n. 13040022 (220-240V) - 13040023 (115V) WHITE

“ your voice, louder ”

INSIDE VIEW

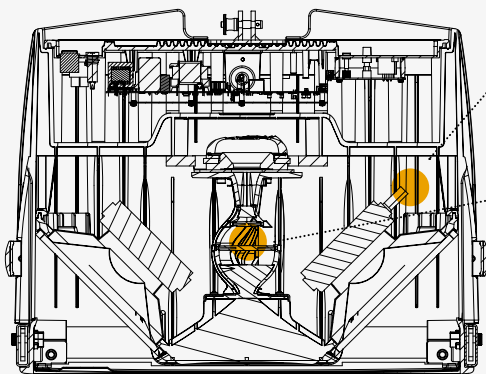

/ LOW FREQUENCIES 8.0" WOOFERS

- 2,0" Voice coil
- Water resistant fibre doped cone
- Polycotton M-roll surround
- High-power magnetic structure

/ HIGH FREQUENCIES

The ND640 large format compression driver is one of the key advantages of the HDL 10-A, the 2.5" voice coil allows a crossover point of 800Hz and therefore almost all the vocal range can be produced by this driver. This allows better coverage, dispersion control and superior efficiency.

With its large format compression driver on a waveguide, the HDL 10-A offers superior intelligibility over distance.



POWERFUL CLASS D AMPLIFIER

RCF's Class-D power amplifier technology packs huge performance operating with high efficiency into a lightweight solution. HDL amplifiers deliver a ultra-fast attack, realistic transient response, and impressive audio performance. The amplifier features a solid machined aluminium structure which not only stabilises the amplifier during transportation but also helps the fan-less heat dissipation. All the HDL amplifiers present SMPS power supply section to produce maximum output and minimum weight.



The integrated mechanics are both fast and reconfigurable, allowing the system engineer to create J-shaped or spiral arrays.

HDL 6-A

ACTIVE TWO-WAY LINE ARRAY MODULE

The HDL 6-A is the ideal choice when line array performance is needed and a fast and easy set-up a must. A 1400 W 2-channel digital amplifier powers the system. A powerful DSP includes crossover, phase correction, limiting and protection. The system features state-of-the-art RCF transducers – two powerful 6.0" woofers for a solid bass reproduction plus a high powered 1.7" voice coil compression driver mounted on a precise 100° x 10° waveguide. HDL 6-A delivers vocal clarity with high definition and an incredible dynamic.



/ CUSTOM DESIGNED WAVEGUIDE

The custom designed waveguide provides a precise coverage of 100° x 10° delivering a superb, linear high frequency response.



p.n. 13000496 (220-240V) - 13000509 (115V) BLACK
p.n. 13000514 (220-240V) - 13000515 (115V) WHITE

- 131 dB max SPL
- 1400 W two-way Class-D switching amplifier
- 65 ÷ 20000 Hz Frequency Range
- 100° x 10° wide, constant directivity coverage angle
- 1.7" voice coil neodymium c. driver
- 2 x high power neodymium 6.0" Woofers
- 48 kHz, 32 bit DSP processing
- Symmetrical design
- FiRPHASE Technology
- 237x470x377 mm - 9.3x18.5x14.8 in (HxWxD)
- Extremely low weight 11.6 kg - 25.57 lbs

“ the tiniest RCF monster ”

/ HIGH FREQUENCIES

The ND340 high power compression driver delivers one of the key advantages of the HDL 6-A. A 1.7" voice coil with a crossover point of 900 Hz allows the driver to produce almost all the vocal range. This allows better coverage and dispersion control and superior efficiency.



The compact and lightweight design of the system is combined with rugged steel mechanics for easy rigging and transportation.

/ LOW FREQUENCIES 6.0" WOOFERS

- 2.0" Edge-wound copper voice coil
- Water resistant ber cone
- Polycotton M-roll surround
- High-power neodymium magnetic structure



p.n. 13000505 (220-240V) - 13000510 (115V) BLACK

The HDL 12-AS is the companion subwoofer for HDL 6-A. Housing a 12" woofer, the HDL 12-AS, is a very compact active sub enclosure and features a powerful 1400W Class-D amplifier. It is the ideal complement to create flown HDL 6-A clusters with outstanding performance. It features a built-in digital stereo crossover (DSP) with adjustable crossover frequency to connect the HDL 6-A line array module or a satellite. The integrated mechanics are both fast and reliable. The heavy-duty front grille is power coated.

FLYABLE MATCHED SUBWOOFER

HDL 12-AS

ACTIVE FLYABLE HIGH POWER SUBWOOFER

- 131 dB max SPL
- 1400 W Class-D switching amplifier
- 40 ÷ 120 Hz Frequency Range
- 12" high power Woofer
- Stereo crossover
- Switchable crossover frequencies
- Polarity reverse switch
- Electronic equalization, soft limiter and protection
- Stereo XLR input, Stereo XLR signal output
- 379x470x508 mm - 14.9x18.50x20 in (HxWxD)
- Extremely low weight 24 kg - 50.9 lbs

2-WAY ARRAYS

NXL 44-A MK2

ACTIVE TWO-WAY ARRAY

NXL 44-A MK2 is a line array column speaker masterfully engineered from the ground up to deliver stellar audio performance for Bands, DJs, Clubs, and Rental Companies. The best-in-class combination of premium RCF transducers and a 2,100W two-channel amplifier produce coherent 100° x 25° coverage for the listening area with up to 135 dB. The two-way design features three 10" neodymium woofers and a 3" driver on an asymmetrical waveguide. The horn's design delivers accurate sound to the coverage area without tilting the enclosure. The speaker delivers an extended frequency range down to 45 Hz and can be used as a stand-alone speaker, flown, or coupled with another NXL 44-A MK2 for extended coverage. Pairing the speaker with subwoofers delivers full-range power for medium-sized concerts and DJ systems. Blending RCF proprietary FIRPHASE and Bass Motion Control DSP processing, the NXL 44-A MK2 speaker is perfectly tuned for absolute sound clarity and deep, powerful bass response. The rugged, tour-ready, high-quality baltic birch plywood cabinet is easy to carry and installed securely using the dedicated rigging points.

/ SUPERIOR TRANSDUCERS

The extended clarity of the 3" compression driver features a neodymium magnet for improved current handling and reduced weight. The best-in-class titanium dome and the Polyimide/Kapton voice coil handle extreme power levels with very low distortion. Three, high-power 10" low-frequency woofers with a new advanced transducer design gain more stability over higher currents, with less distortion, fast transient response, and better heat dissipation.

p.n. 13000609 (220-240V)
p.n. 13000756 (115V)



- Up to 135 dB Sound Pressure Level
- 2100W Class-D Amplifier
- 100° x 25° Constant Directivity Coverage Angle
- 3" Titanium Neodymium Compression Driver
- 3 x 10" High Power Neodymium Woofers
- 45-20000 Hz linear Frequency Response
- Bass Motion Control and FIRPHASE processing
- 8 x M8 Rigging Points and 8 x Quick Lock
- IP Rated Powercon TRUE1 TOP IN/OUT
- 1080x297.5x373 mm - 47.2x11.93x15.83 in (HxWxD)
- 33.4 kg - 73.63 lbs



/ RAISING THE BAR OF SOUND

NXL series consists of full-range column line array speakers ideal for high-powered portable and thanks to flexible rigging options make it for a wide range of sound applications.



NXL 24-A MK2

ACTIVE TWO-WAY ARRAY

NXL 24-A MK2 is a line array column speaker masterfully engineered from the ground up to deliver stellar audio performance for Bands, DJs, Clubs, and Rental Companies. The best-in-class combination of premium RCF transducers and a 2100W two-channel amplifier produce coherent 100° x 30° coverage for the listening area with up to 132 dB. The two-way design features four 6" neodymium woofers and a 3" driver on an asymmetrical waveguide. The horn's design delivers accurate sound to the coverage area without tilting the enclosure. The speaker delivers an extended frequency range down to 60 Hz and can be used as a stand-alone speaker, flown, or coupled with another NXL 24-A MK2 for extended coverage. Pairing the speaker with subwoofers delivers full-range power for medium-sized concerts and DJ systems. Blending RCF proprietary FIRPHASE and Bass Motion Control DSP processing, the NXL 24-A MK2 speaker is perfectly tuned for absolute sound clarity and deep, powerful bass response. The rugged, tour-ready, high-quality baltic birch plywood cabinet is easy to carry and installed securely using the dedicated rigging points.

/ SUPERIOR TRANSDUCERS

The extended clarity of the 3" compression driver features a neodymium magnet for improved current handling and reduced weight. The best-in-class titanium dome and the Polyimide/Kapton voice coil handle extreme power levels with very low distortion. Six, high-power 6" woofers with a new advanced transducer design gain more stability over higher currents, with less distortion, fast transient response, and better heat dissipation.

p.n. 13000610 (220-240V)
p.n. 13000751 (115V)



- Up to 132 dB Sound Pressure Level
- 2100W Class-D Amplifier
- 100° x 30° Constant Directivity Coverage Angle
- 3" Titanium Neodymium Compression Driver
- 4 x 6" High Power Neodymium Woofers
- 60-20000 Hz linear Frequency Response
- Bass Motion Control and FIRPHASE processing
- 4 x M8 Rigging Points and 4 x Quick Lock
- IP Rated Powercon TRUE1 TOP IN/OUT
- 1056x201x274 mm - 41.57x7.91x10.79 in (HxWxD)
- Extremely low weight 24.4 kg - 53.79 lbs

2-WAY MULTIPURPOSE

NX 45-A

ACTIVE TWO WAY MULTIPURPOSE SPEAKER

Featuring RCF precision transducers and a wooden cabinet, the NX 45-A is the RCF's most flexible tool for deploying high-power and pristine sound. As a stand-alone FOH system, a satellite (with subwoofer) or a stage monitor or flown speaker, the NX 45-A has many practical uses. Conceived as the ideal complement to the RCF high-powered HDL System or NXL arrays, it features much of the power and accessories of the TT+ series, such as multiple rigging points and FIRPHASE processing.



/ POWERFUL WOOFER

The low-frequency transducer is a high-power 15" woofer with a 3.0" voice coil, delivering punchy bass. Reproduction of the mid-bass frequencies is accurate, transparent and free from distortion.



/ 4.0" SUPERIOR COMPRESSION DRIVERS

The ND940 large format Compression Driver with 4" voice coil is the key feature of the NX 45-A. The extremely low crossover point of 650Hz is a must for perfect reproduction of the vocal range.

/ DIRECT DRIVE TECHNOLOGY

The voice coil features a high-temperature kapton former. The assembly process takes advantage of the RCF proprietary Direct Drive technology. The diaphragm's suspension has been designed following extensive studies aimed at minimizing distortion and extending low frequency range.

/ AMPLIFIER AND DSP

The two-way 1400 W amplifier features a solid machined aluminium structure, which not only stabilizes the amplifier during transportation but also assists in heat dissipation. The internal DSP has limiters and protections for the transducers and includes FIRPHASE filters to achieve a coherent distribution of sound without phase distortion. A single button shapes the sound for background music when the system plays at minimum volume levels.



- 133 dB SPL Max
- 1400 W 2-way Class-D amplifier
- 45 ÷ 20000 Hz Frequency Range
- 90° x 50° constant directivity coverage
- 15" neodymium woofer, 3.5" voice coil
- Horn loaded 1.4" neodymium c. driver, 4.0" v.c.
- FIRPHASE Technology
- Easy to install with built-in multiple rigging points
- 707x418x402 mm - 27.83x16.46x15.83 in (HxWxD)
- 24 kg - 52.91 lbs

p.n. 13000552 (220-240V) - 13000553 (115V)

“ professional power ”

NX 32-A

ACTIVE TWO WAY MULTIPURPOSE SPEAKER

Featuring RCF precision transducers and a wooden cabinet, the NX 32-A is the RCF's most flexible tool for deploying high-power and pristine sound. As a stand-alone FOH system, a satellite (with subwoofer) or a stage monitor or flown speaker, the NX 32-A has many practical uses. Conceived as the ideal complement to the RCF high-powered HDL System or NXL arrays, it features much of the power and accessories of the TT+ series, such as multiple rigging points and FIRPHASE processing.

/ 3.0" COMPRESSION DRIVERS

The ND840 Compression Driver in pure Titanium with a 3" voice coil allows a crossover point at only 800 Hz. This allows a better impulse response, fast decay and superior efficiency. Lightweight and powerful, our neodymium drivers are a reference in performance and reliability.



/ DIRECT DRIVE TECHNOLOGY

The voice coil features a high-temperature kapton former. The assembly process takes advantage of the RCF proprietary Direct Drive technology. The diaphragm's suspension has been designed following extensive studies aimed at minimising distortion and extending low frequency range.



- 131 dB SPL Max
- 1400 W 2-way Class-D amplifier
- 50 ÷ 20000 Hz Frequency Range
- 90° x 60° constant directivity coverage
- 12" woofer, 2.5" voice coil
- Horn loaded 1.4" neodymium c. driver, 3.0" v.c.
- FIRPHASE Technology
- Easy to install with built-in multiple rigging points
- 600x365x378 mm - 23.62x14.37x14.88 in (HxWxD)
- 20.6 kg - 45.42 lbs



p.n. 13000550 (220-240V) - 13000551 (115V)

NX PROFESSIONAL

NX 9 SERIES

PROFESSIONAL ACTIVE SPEAKERS

The NX 9 series is masterfully engineered to deliver stellar audio performances for solo musicians, bands, and DJs. The new bi-amplified 2100W electroacoustic design provides impressive sound pressure levels, also when used in open-air applications and at long distances, with unbeatable sound quality. The combination of purpose-designed transducers, advanced DSP processing, and a constant directivity waveguide produces coherent coverage to the listening area with distortion-free sound and RCF reliability. Durably built in a rugged all-wood cabinet, NX 9 is tour-ready, and delivers remarkable audio performance and versatility to any professional audio application.



POWER THAT MOVES

With 2100 W power, the 2-channel NX 9 Class-D amplifier is 50% more powerful than previous models, able to manage extreme sound pressure levels with an ultra-fast attack, realistic transient response, and very low heat loss.

REMARKABLE AUDIO PERFORMANCE

The combination of purpose-designed transducers, advanced DSP processing, and a constant directivity waveguide produces coherent coverage to the listening area with distortion-free sound and RCF reliability.

ONE INPUT, THE ONE THAT SOUNDS GOOD

Plug the output of your mixer or audio device into the Line-in Combo (TRS+XLR) Input. The extremely low noise input circuit will deliver an unaltered and clean signal to the power amplifier.



NX 915-A

p.n. 13000674 (220-240 V)
p.n. 13000690 (115 V)

- Up to 131 dB Max SPL
- 2100W Class-D Bi-Amplification
- 1.75" Compression Driver
- 15" Woofer
- FiRPHASE technology
- Bass Motion Control
- 705x420x451 mm
27.76x16.54x17.76 inch
(HxWxD)
- 24.1 kg - 53.13 lbs



NX 912-A

p.n. 13000673 (220-240 V)
p.n. 13000689 (115 V)

- Up to 130 dB Max SPL
- 2100W Class-D Bi-Amplification
- 1.75" Compression Driver
- 12" Woofer
- FiRPHASE technology
- Bass Motion Control
- 620x362x405 mm
24.41x14.25x15.94 inch
(HxWxD)
- 20.8 kg - 45.86 lbs



NX 910-A

p.n. 13000673 (220-240 V)
p.n. 13000689 (115 V)

- Up to 130 dB Max SPL
- 2100W Class-D Bi-Amplification
- 1.75" Compression Driver
- 10" Woofer
- FiRPHASE technology
- Bass Motion Control
- 510x294x333 mm
20.08x11.61x13.11 inch
(HxWxD)
- 16.4 kg - 36.16 lbs

*“ the next generation
of sound ”*



SUPERIOR TRANSDUCERS

Lightweight and powerful, RCF drivers are a reference in high performance. All transducers are designed by RCF engineers in Italy for maximum reliability and perfectly matched components. The new 1.75" voice coil design with Polyimide-Kapton dome features a new bonding technology and reinforcement ribs making it 10 times more rigid than previous models, for increased accuracy and durability. The redesigned phase plug increases sound clarity with less distortion. Low-frequency transducer design gains more stability over higher currents, with less distortion and better heat handling.



TOUR-PROVEN WORKHORSE

NX 9 can operate as either the main system or as a floor monitor. This flexibility makes it a smart choice for a wide range of live sound applications, with maximum strength for intensive use on the road, but also perfect for fixed installation.

A NEW STANDARD IN PORTABLE SOUND

We've merged remarkable audio performance and touring-ready versatility for solo musicians, bands, and DJs. The new bi-amplified 2100W electroacoustic design provides impressive sound pressure levels, also when used in open-air applications and at long distances, with unbeatable sound quality.



S M

STAGE MONITORS

NX STAGE MONITOR SERIES

ACTIVE COAXIAL HIGH-OUTPUT STAGE MONITORS

All the NX Stage Monitors are provided with coaxial transducers which define excellent linearity and high efficiency. The RCF Coaxial Transducers radiate a coherent single spherical wave front with perfect dispersion control.



/ MAXIMUM FLEXIBILITY

Use the NX Series 10-SMA, 12-SMA and 15-SMA as a portable PA system for small to mid-size sound applications. Rugged powder-coated steel pole mounts can be used for flexibility.



NX 12-SMA



/ COAXIAL NEODYMIUM TRANSDUCERS

The newly designed coaxial neodymium transducers provide outstanding audio quality and definition as well as being extremely lightweight.



/ ERGONOMIC HANDLE

Cabinets are made from Baltic Birch plywood, finished with an extremely resistant paint for extensive use on the road. An ergonomic side handle, integrated with the input panel, is provided for easy transport.



NX 15-SMA

p.n. 13000260 (220-240 V)
p.n. 13000261 (115 V)

- 1400 W
- 130 dB Max SPL
- 15" Neo Woofer
- 1.7" Compression Driver
- Jack -XRL IN
XLR OUT
POWERCON AC socket
- 362x650x468mm
14.25x25.59x18.42 inch
(HxWxD)
- 20.2 kg - 44.53 lbs



NX 12-SMA

p.n. 13000235 (220-240 V)
p.n. 13000236 (115 V)

- 1400 W
- 129 dB Max SPL
- 12" Neo Woofer
- 1.7" Compression Driver
- Jack -XRL IN
XLR OUT
POWERCON AC socket
- 324x550x417mm
12.7x21.6x16.4 inch
(HxWxD)
- 16.6 kg - 36.6 lbs



NX 10-SMA

p.n. 13000233 (220-240 V)
p.n. 13000234 (115 V)

- 800 W
- 127 dB Max SPL
- 10" Neo Woofer
- 1.7" Compression Driver
- Jack -XRL IN
XLR OUT
POWERCON AC socket
- 324x450x417mm
12.7x17.7x16.4 inch
(HxWxD)
- 14.3 kg - 31.53 lbs



ST STAGE MONITOR SERIES

ACTIVE HIGH-OUTPUT MULTIPURPOSE MONITOR

ST Series is a practical solution for high intelligibility speech and audio applications, covering infill or delay, production studios, presentations and high-power music sound reinforcement with or without subwoofers. A key requirement for everyday audio systems, delivering simple 'plug and play' solutions, without compromising performance and portability.



ST 15-SMA II



ST 15-SMA II

p.n. 13000638 (220-240 V)
p.n. 13000639 (115 V)

- 1200 W
- 131 dB Max SPL
- 15" Woofer
- 1.4" Compression Driver
- FiRPHASE Technology
- Jack -XRL IN / XLR OUT
VDE AC socket
- 362x673x473mm
14.2x26.4x16.4 inch
(HxWxD)
- 20.7 kg - 45.63 lbs



ST 12-SMA II

p.n. 13000636 (220-240 V)
p.n. 13000637 (115 V)

- 1200 W
- 130 dB Max SPL
- 12" Neo Woofer
- 1.4" Compression Driver
- FiRPHASE Technology
- Jack -XRL IN / XLR OUT
VDE AC socket
- 318x594x400mm
12.52x23.39x15.75 inch
(HxWxD)
- 18 kg - 39.68 lbs

/ STAGE MONITOR

Use it as a stage monitor. The "FLAT" equalization mode is set for monitoring applications, when the system is placed on the floor.

/ LOUDSPEAKER

With an easy 90° rotation and a simple click on the FLAT/ BOOST switch, the ST 15-SMA II turns into a loudspeaker, with the equalization settings in "BOOST" mode.



/ ACCURATE AND POWERFUL WOOFER

ST series features a professional high-power woofer, delivering extremely accurate punchy bass and precise low frequency control, making it an ideal stage monitor/ speaker for personal use and small bands.



/ HIGH-FIDELITY DRIVER

The custom-made compression driver ensures a transparent midrange and extreme accuracy. It features a high performance 1-inch exit throat and 1.4" voice coil, with a frequency range up to 20 kHz.



MAXIMUM FLEXIBILITY

ST Series maximum flexibility philosophy has been maintained for these two new additions; it is possible, in fact, to use the ST 15-SMA II and ST 12-SMA II as a portable PA system, thanks to the rugged powder coated steel pole mount installed on the side.

SUBWOOFERS

SUB 8006-AS

ACTIVE HIGH POWER SUBWOOFER

The SUB 8006-AS is the largest and most powerful active sub woofer in the professional series. Featuring two 18" transducers, with 4" inside/outside voice coils, this cabinet is designed to deliver serious low frequency. Powered by a 2500W Class-D amplifier module, the SUB 8006-AS can perform in the most demanding environments.



The custom designed 18" woofers feature 4" edgewound, inside/outside voice coils for excellent power handling for superior thermal performance.



The SUB 8006-AS input section includes Volume control, a Deep / Punch switch; Signal, Power and Limiter LED's; High pass switch; Phase switch; Cardioid switch; Delay control; Crossover and XLR signal link.



The SUB 8006-AS is powered from a 2500 Watt Class-D amplifier, with an access panel integrated to the rear, with a separate chamber that mechanically insulated cabinet vibrations.

Sophisticated DSP is at the core of a fully-featured input section, providing user selectable crossover functionality, polarity optimization, protection, dynamic limiting and discrete component optimization.



- 141 dB Max SPL
- 5000 W
- 30 ÷ 120 Hz Frequency Range
- 2 x 18" Woofer, 4.0" v.c.
- Jack - XLR IN / XLR OUT
- POWERCON AC socket
- 709x1109x700 mm
27.9x43.6x27.5 in (HxWxD)
- 96.4 kg - 212.53 lbs

p.n. 13000372 (220-240 V) - p.n. 13000373 (115 V)



SUB 8004-AS

ACTIVE SUBWOOFER

The SUB 8004-AS is one of the most powerful 18" subwoofers in pro-sound category. Featuring a high power, hyperventated 18" woofer, with 4" inside/outside voice coils, this cabinet is designed to deliver a serious amount of low frequency. Powered by a 2500W Class-D amplifier module, the SUB 8004-AS can perform in the most demanding environments. The input board includes volume control, deep/punch switch, high pass switch, phase switch, cardioid, time delay.



The subwoofers input section includes Volume control, a Deep / Punch switch; Signal, Power and Limiter LED's; High pass switch; Phase switch; Cardioid switch; Delay control; Crossover and XLR signal link.



/ POWERFUL CLASS D AMPLIFIERS

RCF's Class-D power amplifier technology packs huge performance operating with high efficiency into a lightweight solution. RCF amplifiers deliver an ultra-fast attack, realistic transient response, and impressive audio performance. All the amplifiers present SMPS power supply section to produce maximum output and minimum weight.

/ CABINET & MECHANICS

The RCF cabinets are made of baltic birch plywood coated with a textured black finish. The subs are stackable and light-weight, for easy set-up and tear down. A pole receptacle on top and side allows the use of the box in various configurations. The powder coated front grille integrates a special transparent-to-sound foam backing on the inside to further protect the transducers from dust.



p.n. 13000392 (220-240 V) - p.n. 13000393 (115 V)

- 136 dB Max SPL
- 2500 W
- 18" Woofer, 4" v.c.
- Jack - XLR IN / XLR OUT
- POWERCON AC socket
- 700x558x700 mm - 27.5x21.9x27.5 in (HxWxD)
- 56 kg - 123.46 lbs

SUBWOOFERS

SUB 8003-AS II

ACTIVE SUBWOOFER

The SUB 8003-AS II active subwoofer features the latest generation of RCF woofer technology, Class-D amplifiers and DSP processing with higher-power and enhanced performance. It offers the perfect blend of bass reproduction, high SPL and compact dimensions for mobile use by bands and DJs.

/ CABINET & MECHANICS

The RCF cabinets are made of the best multi-ply hardwood coated with a textured black finish. The subs are stackable and light-weight, for easy set-up and tear down, thanks to the ergonomic handles. A pole receptacle on top and side allows the use of the box in various configurations. The powder coated front grille integrates a special transparent-to-sound foam backing on the inside to further protect the transducers from dust.



FULL FEATURED INPUT BOARD

These subwoofers can be configured from the rear panel, that features a full set of commands:

- OUT SIGNAL, LINE / HIGH PASS
- PRESET
- VOLUME
- TIME

RCF new line of subwoofers suitable for all speakers in its Professional Line of products, offering the maximum flexibility to tailor your PA system to your needs. Featuring strong Baltic birch construction, high quality mechanics, superior acoustic design and premium RCF Precision low frequency transducers, the SUB Series represents the perfect complement for any portable sound reinforcement system.



p.n. 13000432 (220-240 V) - p.n. 13000443 (115 V)

- 135 dB Max SPL
- 2200 W
- 18" Woofer, 4.0" v.c.
- Jack - XLR IN / XLR OUT
- POWERCON AC socket
- 694x523x700 mm
27.32x20.59x27.56 in
(HxWxD)
- 45 kg - 99.21 lbs

“ *the right punch* ”

SUB 905-AS II

ACTIVE SUBWOOFER

The SUB 905-AS II active subwoofer is ideal for building subwoofer satellite systems where compactness and high sound levels are required at the same time. The SUB 905-AS has the most advanced RCF woofer technology, coupled with a powerful 2200 W Class-D amplifier. It offers the perfect blend of bass reproduction, high SPL and compact dimensions for mobile use by bands or DJs.

Both SUB 8003-AS II and SUB 905-AS II are equipped with high power RCF woofers. Our inside/outside voice coils represent unmatched reference in power handling. Their “triple thickness” former transfers the sound to the cone with extreme accuracy and reliability.

FULL FEATURED INPUT BOARD

These subwoofers can be configured from the rear panel, that features a full set of commands:

- OUT SIGNAL, LINE / HIGH PASS
- PRESET
- VOLUME
- TIME

/ LEGENDARY SUBWOOFERS

RCF subwoofers are the first choice of many sound engineers, thanks to the very high SPL levels at very low frequencies, small dimensions compared to the competitors, self-powered design, internal delay control, cardioid configuration options and impressive size/weight to SPL output ratio. Your crowd will be able to live an engaging immersive experience.

- 133 dB Max SPL
- 2200 W
- 15" Woofer, 3.0" v.c.
- Jack - XLR IN / XLR OUT
- POWERCON AC socket
- 600x445x610 mm
23.62x17.52x24.02 in
(HxWxD)
- 30.2 kg - 66.58 lbs



p.n. 13000434 (220-240 V) - p.n. 13000435 (115 V)

CP CONTROL & POWER

DX 1616

MATRIX AUDIO PROCESSOR

DX 1616 AES-Dante remote software. This network-based software designed for Microsoft Windows and Mac OSX allows the management of the DX 1616 Matrix Sound Processor.

Pre-Amp configuration, selecting source types like analog, AES/EBU, Dante

- Designing Input groups for complex applications

- Input source processing with EQ, delay and compressor

Powerful 16x16 router to assign processing tasks to flexible output patches.

/ HOME

The home screen gives the most important information of the signal flow to the system engineer in one view. All inputs with pre-fade level meters including the routing to dedicated DSP modules for typical system tasks for main PA, side PA, subwoofer and distributed speakers. Useful groups of inputs allow easy setup and configuration for any large event application with several mixing desks or multiple sources.

/ SOURCE PROCESSING

The powerful source processing window allows the configuration of the input preamps (analog, AES/EBU, mic/line) and Dante inputs as well. For each source the user can adjust gain, polarity, input EQ, input compressor and input delay.

/ OUTPUT PATCH

With 16 analog outputs, DX 1616 offers flexible routing possibilities. The engineer can use up to 16 individual DSP modules for each output or he can even assign several analog outputs to a specific DSP module to use these outputs as high-quality line drivers. In combination with the RCF CP16 control panel any wiring configuration is supported.

/ DSP MODULE

The DSP module offers high pass filters, low pass filters, parametric EQ, all pass filters, level, compressor and output delay for perfect system control even if no RNet controlled speaker is part of the system.

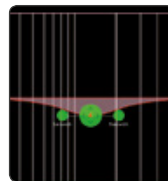

p.n. 12399033



- Hybrid architecture DSP
- 48 kHz sampling, 40 bit floating point engine
- 16 x 16 I/O matrix
- Dante enabled network audio transport
- 8 AES/EBU inputs - 8 AES/EBU outputs
- Ethernet connectivity and control
- Maximum latency 3 ms
- Easy to use software GUI

“connect and manage”



CR 16-ND

CONTROL RACK

The CR 16-ND is a 10 Unit flight case designed to control RCF Professional speaker systems. The CR 16-ND includes one Control 8 that manages the RDNet connection up to 256 devices, one DX 1616 matrix processor that takes care of audio signals routing and processing and one CP 16 control panel to bring audio and control signals to 4 x LK 25 multipin outputs. Each LK 25 has four audio channels, two RDNet channels and two spare sends. Each signal is doubled to XLR redundant outputs.



/ DIGITAL I/O

The DX 1616 matrix audio processor features Ethernet control, Dante redundant inputs, eight AES/EBU inputs and outputs. The signals are managed from a 40 bit floating point, high resolution DSP.

PR 63

POWER RACK

The Power Rack PR 63 features the PD 63 A-419 power distribution with a 63 A Cekon power input with 5m fixed cable. The three-phase power is distributed in a 32 A Cekon output, 4 x LKS19 output, 6 x Powercon output, 1 Powercon auxiliary output to power the CR 16-ND Control Rack.

All outputs are equipped with individual RCBOs (Residual Current-operated Circuit-Breaker with Overcurrent protection) for maximum reliability. In case of damage, only the faulty output is missed while the rest of the system continues to function.



/ 63-AMPERE RACK

From a single 63-Ampere Cekon connector the power rack delivers power distribution to large PA systems, including up to 12+12 left-right line array systems, a large subwoofer system and a complete stage monitoring. 32-Ampere power output for chain motors and 16-Ampere Powercon output to supply CR 16-ND are included.



p.n. 12100004

Dual Switch not included. Ask RCF and adapt the System to your networking protocol.



p.n. 12100006

- 10 RU flight case on shock mounts
- DX 1616 matrix audio processor
- Control 8 master unit
- CP16 control panel
- 16 analog audio inputs, 16 analog audio outputs
- 8 AES/EBU inputs - 8 AES/EBU outputs
- Dante input
- 4 x LK 25 multicore audio/RDNet outputs

- 63 Ampere Cekon power input with 5 m cable
- 32 Cekon outputs
- 4 x LKS 19 outputs
- 6 x Powercon outputs + 1 Powercon auxiliary output
- 24 x individual power line RCBOs
- 32 Ampere and Auxiliary individual front RCBOs
- Tour Grade flight case construction

CABLING AND TRANSPORTATION



The HDL System Karts allows four HDL speakers to be stored and transported in vertical position. All subwoofers are equipped with detachable front wheel boards, which makes setup easy without having the rattling noise of wheels displayed towards the audience when using subs in cardioid setups. RCF active sound reinforcement systems feature sophisticated weather protection to ensure safe operation under worse weather condition. Ease of transportation and weather protection are integral parts of an efficient system.

/ LKS 19 CONNECTORS

With LKS 19 power distribution system uses dedicated fan out cables to connect HDL Systems and companion subwoofers with a single, 19 pin connector. A single cable run can power a full-sized line array column. RCF offers dedicated cabling options for arrays and subwoofers as well as extension cables of 10m or 20m.

/ DEDICATED ACCESSORIES

A full range of custom accessories complements the RCF line array systems. Starting from suspension and stacking to cabling and transportation, RCF provides solutions for a practical assembly, and transportation from the smallest to the largest system.



ACCESSORIES

RIGGING

p.n. 13360334 **FL-B HDL 50**

Flybar for HDL 50-A 4K + 1x Pickup Tab with Shackle + Stacking Bar + Mounting Bracket for inclinometer. Pins included.

p.n. 13360127 **FL-B PK TTL 55**

Pickup Tab with Shackle for HDL 50-A 4K. To be added to the flybar when rigging with 2 motors. Pins included.

p.n. 13360389 **FL-B LINK HDL 50-30**

Link bar for HDL-50-A to HDL 30-A

p.n. 13360128 **SAFETY CHAIN TTL 55**

To be added to the flybar to provide a secondary safety (specially when the cluster is suspended with a single motor). 1 pcs for every Fly Bar suggested.

p.n. 13360129 **HOIST SPACING CHAIN TTL 55**

Hoist Connector Chain to distance the chain-hoist and the chain bag from the flybar. Designed for HDL 50-A 4K and HDL 30-A.

p.n. 13360394 **FL-B PK HDL 30**

Pickup Tab with Shackle for HDL 30-A and HDL 28-A. To be added to the flybar when rigging with 2 motors. Pins included.

p.n. 13360380 **FL-B HDL 30**

Flybar for HDL 30-A or HDL 38-AS + 1x Pickup Tab with Shackle + Stacking Bar + Mounting Bracket for inclinometer. Pins included.

p.n. 13360411 **FL-B HDL 28**

Flybar for HDL 28-A or HDL 36-AS + 1x Pickup Tab with Shackle + Stacking Bar + Mounting Bracket for inclinometer. Pins included.

p.n. 13360432 **FL-B HDL 28 W**

Flybar (white) for HDL 28-A W or HDL 36-AS + 1x Pickup Tab with Shackle + Stacking Bar + Mounting Bracket for inclinometer. Pins included.

p.n. 13360218 **FL-B HDL 20-18**

Flybar for HDL 20-A or HDL 18-AS + 1x Pickup Tab with Shackle + Stacking Bar. Pins included.

p.n. 13360229 **FL-B LGT HDL 20**

Flybar for HDL 20-A + Pole Mount + 1x Pickup Tab with Shackle + Stacking Bar. Pins included.

p.n. 13360225 **FL-B LINK HDL 20-18 2X**

Link bar for HDL 20-A and HDL 18-AS. Pins included. (two pieces)

p.n. 13360221 **FL-B PK HDL 20-18**

Pickup Tab with Shackle for HDL 20-A and HDL 18-AS. To be added to the flybar when rigging with 2 motors. Pins included.

p.n. 13360274 **FL-B HDL 10**

Flybar for HDL 10-A + 1x Pickup Tab with Shackle + Stacking Bar. Pins included.

p.n. 13360314 **FL-B HDL 10 W**

Flybar for HDL 10-A + 1x Pickup Tab with Shackle + Stacking Bar. Pins included.

p.n. 13360296 **FL-B LINK HDL 10-15 2X**

Link bar for HDL 10-A and HDL 15-AS. Pins included. (two pieces)

p.n. 13360276 **FL-B LGT HDL 10**

Flybar for HDL 10-A + Pole Mount + 1x Pickup Tab with Shackle + Stacking Bar. Pins included.

p.n. 13360313 **FL-B LGT HDL 10 W**

Flybar for HDL 10-A W (white) + Pole Mount + 1x Pickup Tab with Shackle + Stacking Bar. Pins included.

p.n. 13360371 **CL-BR HDL 6**

Clamp Bracket for HDL 6-A and HDL 26-A

p.n. 13360360 **FL-B HDL 6**

Flybar for HDL 6-A; HDL 12-AS; HDL 26-A; HDL 35-AS + 1x Pickup Tab with Shackle + Stacking Bar + Pole Mount + M20 Adapter. Pins included.

p.n. 13360373 **FL-B HDL 6 W**

Flybar for HDL 6-A W + 1x Pickup Tab with Shackle + Stacking Bar + Pole Mount + M20 Adapter. Pins included.

RIGGING

p.n. 13360375 **FL-B LINK HDL 6-12 2X**

Link bar for HDL 6-A and HDL 12-AS; HDL 26-A and HDL 35-AS (two pieces)

p.n. 13360372 **FL-B PK HDL 6**

Pickup Tab with Shackle for HDL 6-A; HDL 12-AS; HDL 26-A; HDL 35-AS. To be added to the flybar when rigging with 2 motors. Pins included.

p.n. 13360345 **FL-B NXL 44**

Fly bar for NXL 44-A MKII up to 2 pieces

p.n. 13360346 **FL-B LINK NXL 44**

Accessory to link a second NXL 44-A to a flying NXL 44-A (straight or 2 angles)

p.n. 13360278 **FL-B NXL 24**

Fly bar for NXL 24-A MKII up to 2 pieces

p.n. 13360279 **FL-B LINK NXL 24**

Accessory to link a second NXL 24-A to a flying NXL 24-A (straight or 2 angles)

p.n. 13360351 **AZM-BR 2X**

To be added for horizontal array control

p.n. 13360398 **V-BR NX 45**

Wall mount brackets with adjustable inclination for NX 45-A

p.n. 13360328 **V-BR TT 22 II**

Wall mount brackets with adjustable inclination for NX 32-A and NX 10-A II

STACKING

p.n. 13360377 **PM-KIT 3X HDL 6**

Pole mount kit for 3 HDL 6-A or 3 HDL 26-A. Pins included. + Stacking Bar

p.n. 13360285 **PM-KIT 2X HDL 20**

Accessory for 2 HDL 20 on a pole mount. Pins included. + Stacking Bar

p.n. 13360393 **STCK-KIT 2X HDL 30**

Stacking kit for HDL 30-A, HDL 28, HDL 20-A and HDL 10-A. Pins included.

p.n. 13360347 **STCK-KIT NXL 44**

Accessory for stacking 2 NXL 44-A MKII on SUB 8006 or 8004 (or M20 pole)

p.n. 13360280 **PM-KIT NXL 24**

Adjustable pole accessory for stacking NXL 24-A MKII on SUB 8004 (or M20 pole)

p.n. 13360281 **STCK-KIT NXL 24**

Accessory for stacking 2 NXL 24-A MKII on SUB 8006 or 8004 (or M20 pole)

p.n. 13360232 **AC PMX**

Adjustable pole - up to 60Kg for HDL 20-A, HDL 18-A and HDL 15-A

p.n. 13360231 **STCK-KIT SUB 8006**

Accessory to lock FLY BAR HDL 20-18 to the SUB 8006-AS. Accessory to lock FLY BAR HDL 10 to the SUB 8004-AS. M20 fixing point. Two pieces. Pins included.

p.n. 13360109 **AC PRO-FS**

Professional loudspeaker floor stand

p.n. 13360111 **AC PRO-LF**

Professional adapter sleeve for loudspeaker floor stand

p.n. 13360110 **AC PRO-PM**

Adjustable pole accessory for satellite loudspeaker on a subwoofer

p.n. 13360067 **PM-KIT M20**

Adjustable pole for subwoofer

p.n. 13360068 **AC PMA TT**

Adjustable speaker pole M20

p.n. 13360034 **AC PMA**

Adjustable speaker pole

p.n. 13360031 **AC EB 4X**

kit including 4 pcs M10 eye bolts

ACCESSORIES

QUICK LOCK PINS (4X)

p.n. 13360335 QL-PIN D11.2 L31 4X

| PRODUCT | | POSITION | TPOLOGY |
|-------------|----------|----------|---------|
| HDL 50-A 4K | 13000641 | FRONT | LINK |
| HDL 50-A 4K | 13000641 | FRONT | LOCK |

p.n. 13360340 QL-PIN D12.6 L32 4X

| PRODUCT | | POSITION | TPOLOGY |
|-------------|----------|----------|---------|
| HDL 50-A 4K | 13000641 | REAR | LINK |

p.n. 13360132 QL-PIN D11.1 L44.5 4X

| PRODUCT | | POSITION | TPOLOGY |
|-------------|----------|----------|---------|
| FL-B HDL 50 | 13360334 | FRONT | LINK |

p.n. 13360219 QL-PIN D9.6 L21.3 4X

| PRODUCT | | POSITION | TPOLOGY |
|------------------|----------|----------|---------|
| HDL 20-A | 13040007 | FRONT | LINK |
| HDL 20-A | 13040007 | FRONT | LOCK |
| HDL 18-AS | 13040009 | FRONT | LINK |
| HDL 10-A | 13040016 | FRONT | LINK |
| HDL 10-A | 13040016 | FRONT | LOCK |
| HDL 30-A | 13000511 | FRONT | LINK |
| HDL 30-A | 13000511 | FRONT | LOCK |
| HDL 36-AS | 13000583 | FRONT | LINK |
| HDL 36-AS | 13000583 | FRONT | LOCK |
| HDL 38-AS | 13000580 | FRONT | LINK |
| HDL 38-AS | 13000580 | FRONT | LOCK |
| HDL 28-A | 13000579 | FRONT | LINK |
| HDL 28-A | 13000579 | FRONT | LOCK |
| HDL 28-A W | 13000605 | FRONT | LINK |
| HDL 28-A W | 13000605 | FRONT | LOCK |
| HDL 6-A | 13000496 | FRONT | LINK |
| HDL 6-A | 13000496 | REAR | LINK |
| HDL 26-A | 13000588 | FRONT | LINK |
| HDL 26-A | 13000588 | REAR | LINK |
| HDL 12-AS | 13000505 | FRONT | LINK |
| HDL 12-AS | 13000505 | REAR | LINK |
| HDL 35-AS | 13000575 | FRONT | LINK |
| HDL 35-AS | 13000575 | REAR | LINK |
| FL-B NXL 24 | 13360278 | | LINK |
| FL-B NXL 44 | 13360345 | | LINK |
| PM-KIT 2X HDL 20 | 13360285 | FRONT | LINK |
| PM-KIT 2X HDL 20 | 13360285 | REAR | LINK |
| FL-B LINK NXL 44 | 13360346 | | LINK |
| STCK-KIT NXL 44 | 13360347 | | LINK |
| FL-B HDL 6 | 13360360 | FRONT | LINK |
| KRT-WH 6X HDL 6 | 13360366 | FRONT | LINK |

QUICK LOCK PINS (4X)

p.n. 13360219 QL-PIN D9.6 L21.3 4X

| PRODUCT | | POSITION | TPOLOGY |
|-----------------------|----------|----------|---------|
| FL-B LINK HDL 6-12 2X | 13360375 | | LINK |
| PM-KIT 3X HDL 6 | 13360377 | | LINK |
| KRT-WH 4X HDL 30 | 13360382 | FRONT | LINK |
| KRT-WH 4X HDL 28 | 13360412 | FRONT | LINK |

p.n. 13360220 QL-PIN D9.6 L26.9 4X

| PRODUCT | | POSITION | TPOLOGY |
|------------------------|----------|----------|---------|
| HDL 20-A | 13040007 | REAR | LINK |
| HDL 30-A | 13000511 | REAR | LINK |
| HDL 28-A | 13000579 | REAR | LINK |
| HDL 28-A W | 13000605 | REAR | LINK |
| FL-B LINK HDL 20-18 2X | 13360225 | | LINK |
| FL-B LINK HDL 10-15 2X | 13360296 | | LINK |
| KRT-WH 4X HDL 20 | 13360223 | | LINK |
| KRT-WH 4X HDL 10 | 13360275 | | LINK |
| FL-B LGT HDL 20 | 13360229 | | LINK |
| FL-B LGT HDL 10 | 13360276 | | LINK |
| FL-B LINK NXL 24 | 13360279 | | LINK |

p.n. 13360222 QL-PIN D9.6 L31 4X

| PRODUCT | | POSITION | TPOLOGY |
|------------------------|----------|----------|---------|
| FL-B HDL 20-18 | 13360218 | FRONT | LOCK |
| FL-B HDL 20-18 | 13360218 | REAR | LINK |
| FL-B PK HDL 20-18 | 13360221 | | LINK |
| FL-B LINK HDL 20-18 2X | 13360225 | | LINK |
| STCK-KIT SUB 8006 | 13360231 | | LINK |
| FL-B HDL 10 | 13360274 | FRONT | LOCK |
| FL-B HDL 10 | 13360274 | REAR | LINK |
| FL-B HDL 6 | 13360360 | REAR | LINK |
| CL-BR HDL 6 | 13360371 | | LINK |
| FL-B PK HDL 6 | 13360372 | | LINK |
| FL-B HDL 30 | 13360380 | FRONT | LOCK |
| FL-B HDL 30 | 13360380 | REAR | LINK |
| FL-B HDL 28 | 13360411 | FRONT | LOCK |
| FL-B HDL 28 | 13360411 | REAR | LINK |
| STCK-KIT 2X HDL 30 | 13360393 | | LINK |

ACCESSORIES

TRANSPORTATION

p.n. 13360336 **KRT-WH 4X HDL 50**
HDL 50-A 4K transportation kart for 4 modules

p.n. 13360382 **KRT-WH 4X HDL 30**
Kart with wheels for 4 HDL 30-A

p.n. 13360430 **KRT-WH 3X HDL 38**
HDL 38-AS cart to store and transport up to 3 modules

p.n. 13360431 **KRT-WH 3X HDL 36**
HDL 36-AS cart to store and transport up to 3 modules

p.n. 13360412 **KRT-WH 4X HDL 28**
Kart with wheels for 4 HDL 28-A

p.n. 13360348 **KRT-WH SUB 9007**
Kart for 1 SUB 9007-AS

p.n. 13360361 **KRT-WH SUB 9006**
Kart for 1 SUB 9006-AS

p.n. 13360223 **KRT-WH 4X HDL 20**
Kart with wheels for 4 HDL 20

p.n. 13360275 **KRT-WH 4X HDL 10**
Kart with wheels for 4 HDL 10

p.n. 13360366 **KRT-WH 6X HDL 6**
Kart with wheels for 6 HDL 6-A or 6 HDL 26-A

p.n. 13360385 **KRT-WH SUB 9004**
Kart for 1 SUB 9004-AS

p.n. 13360238 **WH PRO 4X**
Kit 4 swivel castor 100mm wheels with roller bearing

COVERS

p.n. 13360338 **CVR 4X HDL 50**
Cover for 4 pieces of HDL 50-A 4K on cart

p.n. 13360433 **CVR 3X HDL 38**
Cover for 3 pieces of HDL 38-AS on cart

p.n. 13360434 **CVR 3X HDL 36**
Cover for 3 pieces of HDL 36-AS on cart

p.n. 13360386 **CVR 4X HDL 30**
Cover for 4 pieces of HDL 30-A on cart

p.n. 13360422 **CVR 4X HDL 28**
Cover for 4 pieces of HDL 28-A on cart

p.n. 13360339 **CVR SUB 9007**
Cover for 1 SUB 9007-AS

p.n. 13360363 **CVR SUB 9006**
Cover for 1 SUB 9006-AS

p.n. 13360397 **CVR SUB 9004**
Cover for 1 SUB 9004-AS

p.n. 13360167 **CVR NX10-SMA**
Cover for NX 10-SMA

p.n. 13360174 **CVR NX15-SMA**
Cover for NX 15-SMA

COVERS

p.n. 13360168 **CVR NX12-SMA**
Cover for NX 12-SMA

p.n. 13360320 **CVR ST 15-SMA**
Cover for ST 15-SMA II

p.n. 13360319 **CVR ST 12-SMA**
Cover for ST 12-SMA II

p.n. 13360209 **CVR HD 12-32**
Cover for HD 32-A

p.n. 13360438 **CVR HD 15**
Protection cover for HD 35-A and HDM 45-A.

p.n. 13360242 **CVR SUB 8006**
Cover for SUB 8006-AS

p.n. 13360286 **CVR SUB 8004**
Cover for SUB 8004-AS

p.n. 13360378 **CVR SUB 8003 II**
Cover for SUB 8003-AS II

p.n. 13360379 **CVR SUB 905 II**
Cover for SUB 905-AS II

p.n. 13360409 **CVR NX 45**
Cover for NX 45-A

p.n. 13360408 **CVR NX 32**
Cover for NX 32-A

p.n. 13360478 **CVR NX 915**
Cover for NX 915-A

p.n. 13360496 **CVR NX 912**
Cover for NX 912-A

p.n. 13360495 **CVR NX 910**
Cover for NX 910-A

RAIN PROTECTIONS

p.n. 13360337 **RP 1X HDL 50**
Set of 2x rain covers to protect HDL 50-A 4K input boards

p.n. 13360388 **RP 1X HDL 30**
Set of 2x rain covers to protect HDL 30-A, HDL 28-A and HDL 35-AS input boards

p.n. 13360352 **RP 1X SUB 9007**
Rain cover to protect SUB 9007-AS input board

p.n. 13360362 **RP 1X SUB 9006**
Rain cover to protect SUB 9006-AS input board

p.n. 13360437 **RP 1X SUB 9004**
Rain cover to protect SUB 9004-AS input board

p.n. 13360233 **RP 1X SUB 8006**
1 x Rain Cover for SUB 8006-AS amplifier

p.n. 13360283 **RP 1X HDL 20**
Rain cover for 2 HDL 20/10 or 2 HDL 18/15

p.n. 13360381 **RP 1X HDL 6**
1 x Rain Cover for HDL 6 and HDL 26-A

ACCESSORIES

CONTROL AND AUDIO CABLES

p.n. 13360102 **AC XLR 3M3F**
3 XLR Female connector with nickel body and silver contacts
3 XLR Male connector with nickel body and silver contacts

p.n. 12399021 **CBL LKS 25-2 FANOUT**
25 pin to 8X XLR, cable 1.0 meters, fanout 1.0 meters

p.n. 12399022 **CBL LK 25 MULTIPIN 20M**
25 pin male female cable 20 meters

p.n. 12399023 **CBL LK 25 MULTIPIN 10M**
25 pin male female cable 10 meters

p.n. 12399016 **CBL ETHERCON 0.7M**
Ethercon cable 0.7 meters. Compatible with RDNET

p.n. 12399017 **CBL ETHERCON 1.5M**
Ethercon cable 1.5 meters. Compatible with RDNET

p.n. 12399035 **CBL ETHERCON 3M**
Ethercon cable 3 meters. Compatible with RDNET

p.n. 12399018 **CBL ETHERCON 5M**
Ethercon cable 5 meters. Compatible with RDNET

p.n. 12399019 **CBL ETHERCON TO XLR F 0.2M**
Adapter cable Ethercon to XLR female 0.2 meters

p.n. 12399020 **CBL ETHERCON TO XLR M 0.2M**
Adapter cable Ethercon to XLR male 0.2 meters

POWER DISTRIBUTION

p.n. 12399024 **CBL LKS 19 ARRAY FANOUT**
Array fan out cable 0.5 - 1.3 - 2.1 - 2.9 - 3.7 - 4.5 M

p.n. 12399025 **CBL LKS 19 SUB FANOUT**
Sub fan out cable 2X 2.5 - 2X 5.0 - 2X 10.0 M

p.n. 12399026 **CBL LKS 19 BREAKOUT**
Breakout box with LKS 19 Input/Output to 6x powercon

p.n. 13360146 **CBL LKS 19 POWER 20M**
LKS 19 power cable 20 meters

p.n. 12399027 **CBL LKS 19 POWER 10M**
LKS 19 power cable 10 meters

p.n. 12399028 **CBL POWERCON LINK 10M**
Powercon link cable 10 meters

p.n. 12399029 **CBL POWERCON LINK 5M**
Powercon link cable 5 meters

p.n. 12399030 **CBL POWERCON LINK 1.5M**
Powercon link cable 1.5 meters

p.n. 12399031 **CBL POWERCON LINK 0.7M**
Powercon link cable 0.7 meters

p.n. 13360145 **CBL POWER BOX 6X**
Breakout box with LKS 19 Input/Output to 6x powercon

UPGRADES

p.n. 12399061 **HDL 50 UPGRADE KIT 4K**
This kit includes 2 stereo amplification modules assebled on an heatsink plate to upgrade the HDL 50-A to HDL 50-A 4K.



www.rcf.it

HEADQUARTERS:

RCF S.p.A. Italy
tel. +39 0522 274 411
e-mail: info@rcf.it

RCF UK
Int. +44 (0) 1702 800846
e-mail: info@rcfaudio.co.uk

RCF France
tel. +33 6 24 15 81 76
e-mail: france@rcf.it

RCF Germany
tel. +49 2203 925370
e-mail: germany@rcf.it

RCF Spain
tel. +34 91 817 42 66
e-mail: info@rcfaudio.es

RCF Benelux
tel. +49 (0) 2203 9253724
e-mail: benelux@rcf.it

RCF USA Inc.
tel. +1 732-9026100
e-mail: info@rcf-usa.com