



INSTALLED SOUND

RCF Installed Sound speaker systems range represents a prominent chapter in the long history of RCF, started in 1949.

Whether a speaker system is designed for permanent installation or for portable PA situations, RCF has a solution with high level of audio fidelity and intelligibility, offering superior sound definition.

This requirement has fostered the need for Audio Professionals to be able to offer a range of speaker systems combined with dedicated Processing and Amplification Technologies that are superior in Acoustic Performance and Control.

The RCF product portfolio is one of the most comprehensive in the market place today offering true integrated audio solutions.

This catalogue includes speaker systems designed to meet all pro-audio contractors requirements for fixed installations like café or theme bars, retail outlets, places of worship, theatres, restaurants, live venues, dance clubs, theme parks, airports, hotels, railway stations, shopping malls, auditoriums, congress centres or major sporting stadia.....

From architectural design and industry standard monitor speakers to digital steerable arrays, from the compact near and medium field "two-way systems" to the "large format" horn-loaded arrayable systems for stadia and long throw sound reinforcement applications, all RCF speaker systems designed for fixed installations offer dedicated controlled horn directivity. For the maximum safety with no compromises RCF wooden cabinets have internal steel reinforcement brackets dimensioned over the most severe safety standards.

The speaker series included in this catalogue feature some of RCF's exclusive designs and technologies such as RCF Precision Woofers and Compression Drivers, "CMD" Coverage Matching Design horns providing consistent horizontal and vertical pattern control through the usable frequency range, RCF exclusive "LICC" Crossover Systems, matching amplification and control systems to fully optimise the high performance and long term reliability RCF is renowned for. RCF speaker systems equipped with compression drivers also have the RCF built in dynamic electronic protection, providing a high standard in reliability.

RCF is one of only a few loudspeaker manufacturers worldwide who completely manufactures transducers, speaker systems and amplification and control electronics.

Our 70 years heritage in Audio research and development combined with the latest manufacturing processes and high quality materials gives us the opportunity to create a complete range of systems that can individually or combined meet today's high standards in audio requirements.

INDEX

VSA II

VSA 2050 II	page	6-9
VSA 1250 II	page	6-9
VSA 850 II	page	6-9

HL SYSTEM

HL 2290	page	10-13
HL 2260	page	10-13
HL 2240	page	10-13
HS 2200	page	10-13
HL 20-WP	page	14-15
H 1315	page	16-17
H 1315-WP	page	16-17

V MAX

V 45	page	18-19
V 35	page	20-21
V 10	page	22-23
V 6	page	24-25
V 221-S	page	26-27
V 218-S	page	28-29

C MAX

C MAX 4112	page	30-31
C MAX 4110	page	32-33

E MAX

E MAX 3112	page	34-35
E MAX 3110	page	36-37

COMPACT SERIES

C 5215-99	page	38-41
C 5215-96	page	38-41
C 5215-94	page	38-41
C 5215-66	page	38-41
C 5215-64	page	38-41

COMPACT SERIES

C 5212-99	page	42-45
C 5212-96	page	42-45
C 5212-94	page	42-45
C 5212-66	page	42-45
C 5212-64	page	42-45
C 3110-126	page	46-49
C 3110-96	page	46-49
C 3108-126	page	50-53
C 3108-96	page	50-53

COMPACT M

COMPACT M 12	page	54-55
COMPACT M 10	page	56-57
COMPACT M 08	page	58-59
COMPACT M 06	page	60-61
COMPACT M 05	page	62-63

L SERIES

L 2406T	page	64-65
---------	------	-------

P SERIES

P 5228-L	page	66-67
P 4228	page	68-69
P 3108	page	70-71
P 1108T	page	72-73
P 6215	page	74-75
P 3115T	page	76-77
P 2110T	page	78-79
P 8015S	page	80-81

ART SERIES

ART 725 MK4	page	82-83
ART 315 MK4	page	84-85
ART 312 MK4	page	84-85
ART 310 MK4	page	84-85

SUBWOOFER SERIES

S 8028 II	page	86-87
S 8018 II	page	88-89
S 8015 II	page	90-91
S 8015 LP	page	92-93
SUB S12	page	94-95
SUB S10	page	96-97
S 4012	page	98-99

MONITOR SERIES

MR 50T	page	100-101
MR 40T	page	102-103
MF 33EN	page	102-103
WMF 33EN	page	102-103
MQ 80P	page	104-105
MQ 60H	page	104-105
MQ 50	page	106-107
MQ 50i	page	106-107
MQ 50C	page	108-109
MQ 30P	page	108-109
MQ 100L	page	110-111
MQ 90S	page	110-111

PRO AMPLIFIERS

QPS 9600	page	112-113
HPS 2500	page	112-113
HPS 1500	page	112-113
IPS 3700	page	114-115
IPS 2700	page	114-115
IPS 1700	page	114-115
IPS 700	page	114-115

DIGITAL MIXER AMPLIFIER

DMA	page	116-117
DPA	page	118-119

DPS AMPLIFIER

DPS 604X	page	120-121
-----------------	------	---------

DIGITAL PROCESSORS

DX 1616	page	122-123
DX 4008	page	122-123
DX 2006	page	122-123

AUDIO MATRIX

MZ 8060	page	124-125
----------------	------	---------

AUDIO SOURCE

MS 1033	page	126-127
----------------	------	---------

ACCESSORIES

UNIVERSAL ACCESSORIES FOR LOUDSPEAKERS	page	128-129
UNIVERSAL LINE TRANSFORMERS	page	130
ACCESSORIES FOR VSA II	page	130

VSA

VERTICAL STEERABLE ARRAY

VSA 2050 II | VSA 1250 II | VSA 850 II

The VSA II system allows the audio signal to be addressed exactly to the listening area, avoiding the radiation of the acoustic energy to ceilings and empty floors; this eliminates any bad reflections that would affect speech intelligibility, mainly in critical environments with high reverberation. VSA offers a precise directivity and control to give high intelligibility performance with wide frequency response, high-dynamics and coherence at distance. Thanks to the reliable and powerful amplifiers, the accurate speaker design, and the high efficiency of the digital technology, VSA II is able to achieve an extended and stable coverage, preserving at the same time a smooth uniform horizontal coverage.



/ POWERFUL TRANSDUCERS

The state of the art transducer developed for the VSA II offers the highest possible intelligibility and wider frequency response, according to RCF philosophy. A 1,4 tesla flux density is the result of the massive neodymium magnet to get an incredible mid frequency dynamic range. The neodymium magnet is very lightweight and helps to compact the size of the overall system.

/ ARCHITECTURAL CAMOUFLAGE

The unobtrusive and robust aluminium cabinet blends seamlessly in any architecturally sensitive environments. The standard colors are white RAL 9003 and black RAL 9005, and custom colours are available on request. The modular design approach offers a uniform heat dissipation for maximum consistency over time. The installation is particularly simple thanks to the drilling template on the wooden package and the light weight of the speaker. Optional swivel brackets are available on request if the column has to be oriented horizontally.



VSA 2050 II



VSA 1250 II



VSA 850 II

- 50 W Class-D power amplifier for each transducer (VSA 2050 II: 20 | VSA 1250 II: 12 | VSA 850 II: 8)
- 48 kHz 32 bit processing
- Vertical Dispersion controlled up to 10° till 300 Hz
- Power Supply 115/230Vac; 24Vdc
- Extruded aluminium body
- Ceramic block terminals and thermal fuse on OdB balanced priority input
- Standard installation accessories included
- Easy and fast configuration
- Indicators and control for EN 60849 monitoring facility
- Custom colors available



SPECIFICATIONS

VSA 2050 II

p.n. 131.00.022 [220-240V] White
 p.n. 131.00.023 [115V] White
 p.n. 131.00.053 [220-240V] Black
 p.n. 131.00.054 [115V] Black
 p.n. 131.00.024 [220-240V Custom Color]
 p.n. 131.00.031 [115V Custom Color]

VSA 1250 II

p.n. 131.00.025 [220-240V] White
 p.n. 131.00.026 [115V] White
 p.n. 131.00.055 [220-240V] Black
 p.n. 131.00.056 [115V] Black
 p.n. 131.00.027 [220-240V Custom Color]
 p.n. 131.00.032 [115V Custom Color]

VSA 850 II

p.n. 131.00.028 [220-240V] White
 p.n. 131.00.029 [115V] White
 p.n. 131.00.058 [220-240V] Black
 p.n. 131.00.442 [115V] Black
 p.n. 131.00.030 [220-240V Custom Color]
 p.n. 131.00.033 [115V Custom Color]

ACOUSTICAL

FREQ. RESPONSE (-10 dB)	100 Hz ÷ 18 kHz	120 Hz ÷ 18 kHz	130 Hz ÷ 18 kHz
MAX SPL (A-weighted at 30 m)	96 dB	94 dB	93 dB
COVERAGE ANGLE (-6 dB)	130° horiz. x 10°/30° vert.	130° horiz. x 10°/30° vert.	130° horiz. x 10°/30° vert.
VERTICAL STEERING ANGLE	selectable from 0° to -40°	selectable from 0° to -40°	selectable from 0° to -40°
TRANSDUCERS	20 x 3.5" full range	12 x 3.5" full range	8 x 3.5" full range
AMPLIFIERS	20 x class D 50 W	12 x class D 50 W	8 x class D 50 W
PROTECTIONS	short circuit, thermal	short circuit, thermal	short circuit, thermal
AC POWER SUPPLY	650 W switching type	650 W switching type	650 W switching type
DC POWER SUPPLY	24 Vdc Back-up	24 Vdc Back-up	24 Vdc Back-up
CONNECTORS	Ceramic terminal block	Ceramic terminal block	Ceramic terminal block

TECHNICAL

PROCESSING	32 bit floating point DSP 24 bit AD converters, 48 kHz		
FUNCTIONALITIES	PEQs Channels Compression Beam-forming Speaker limiter and protection		
INPUT SENSITIVITY	0 dBu		
INPUT CONNECTORS	Balanced screw terminal Ceramic block		
INPUT CONTROL	Remote control dedicated IR input Priority input command Status remote monitoring Stand by remote command		
LEDs	Active Communication Status Emergency		

PHYSICAL

DIMENSIONS (W x H x D)	4.9" x 81.5" x 3.8" 125 x 2070 x 97 mm	4.9" x 52.7" x 3.8" 125 x 1340 x 97 mm	4.9" x 38.5" x 3.8" 125 x 980 x 97 mm
WEIGHT	41.8 lbs - 19 kg	30.8 lbs - 14 kg	22 lbs - 10 kg
COLOR	Black RAL 9005, White RAL 9003 or customizable		
CABINET	Powder coated aluminium extrusion	Powder coated aluminium extrusion	Powder coated aluminium extrusion
HARDWARE	2 x speaker wall mounting flange	2 x speaker wall mounting flange	2 x speaker wall mounting flange

1) Measured on axis in the far field with 1 watt (2.83V RMS, 8 ohm) input and referenced to 1 meter distance using the inverse square law. Listed sound pressure represents an average from 300 Hz to 3 kHz.

2) Using 20 Hz to 20 kHz, Pink Noise Spectrum, 2 hours, + 6 dB crest factor, with RMS voltage calculated on speaker minimum impedance.

3) Recommended Amplifier is a power capability value that should be taken as a guide.

VSA

VERTICAL STEERABLE ARRAY

VSA 2050 II | VSA 1250 II | VSA 850 II

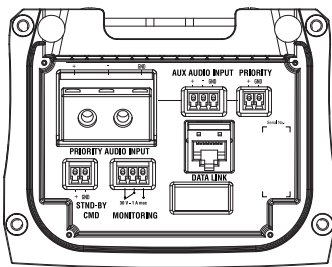

/ CONNECTIONS PANEL

The audio connections are secure thanks to the plastic cap/shield on the bottom-end of the column. Two balanced inputs are available for independent wiring for Priority and Aux audio sources. The Priority one is available on ceramic terminal blocks with a thermal fuse for voice alarm applications and can be controlled by a fail-safe activation command. The Data Link port allows the control and monitoring from the RNet Network, while the monitoring port can be used for 'faulty' remote indications.

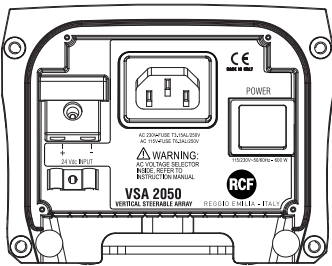

/ POWER PANEL

AC and DC Power supply connections are on top of the column, protected by a plastic cover. Connectors are VDE type for AC and ceramic terminal block for DC.

APPLICATIONS

- Intelligible audio transmission in critical acoustical environments
- Transportation halls
- Sports arenas
- Convention centres
- Conference halls
- Auditoriums
- Houses of Worship

RELATED ACCESSORIES

SWM-BR VSA II

p.n. 133.60.410 White - p.n. 133.60.442 Black
Pair of horizontal brackets for mounting one VSA on the wall with an inclination up to 60°.

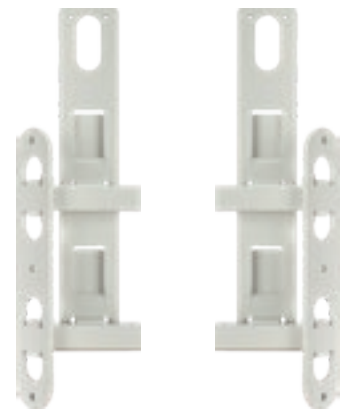

Other accessories are available on page 122

VSA SMART RC

The VSA-RC is an easy way to control the VSA speakers through the VSA Remote App available on iOS or Android. The following data are configurable on each VSA through the VSA-RC remote control:

- Select the proper beaming and tilting configuration
- Delay in metres
- Voice/music optimization filters
- Polarity
- Mute
- Volume
- Stand-By



(p.n. 13160330)

The I/R receiving diode is recessed, and its directivity coverage has been narrowed to receive I/R commands just from the dedicated remote located in front of the column axis.

Thanks to this, if two columns are one close to the other, there is no risk to drive two receivers at the same time.



NETWORKED MANAGEMENT

RDNet NETWORKED MANAGEMENT

The RCF RDNet is the perfect tool to help you to configure your VSA II system setup in any venues. The software helps to monitor and control all individual speakers with its own DSP setting and to secure the best performance of the system configuration.

RDNet is a secure and robust management for small, medium, and arena-sized sound systems as well as complex and extended installations. Based on a proprietary network protocol RDNet provides straightforward monitoring and intuitive control of the RCF audio system down to every connected device/object.

AUDIO CONTROL WINDOW

Two different audio channels available, the Priority Channel will be active when needed if the priority function is activated, overriding the AUX Channel.

A delay on the DSP improves the intelligibility on big installations. The parameter to be set is not the time, but the distance (range: from 0 to 99 metres, 3 m steps) between the first loudspeaker line and the one of the loudspeaker to be set. The polarity control (Phase) is helpful to minimise destructive interferences due to particular loudspeaker positions.

DIRECT CONNECTION OR NETWORK

Each VSA II column can be programmed directly from the RDNet on a PC via an USB to RS-485 converter. A Control2 or Control8 interface can be used for the programming of complex systems of 2 or more VSA.

EQUALIZER

The equalization can be chosen among 6 different settings, 3 of which are user custom with a complete range of available equalization types.

- **Flat**
No equalization (flat frequency response)
- **Speech**
Equalization optimised for speech
- **Music**
Equalization optimised for music
- **Custom 1 – 2 – 3**
3 custom equalization by setting max. 8 filters.

BEAM CONTROL

Three different operational modes are available for a precise and fast set up of the column in any environment.

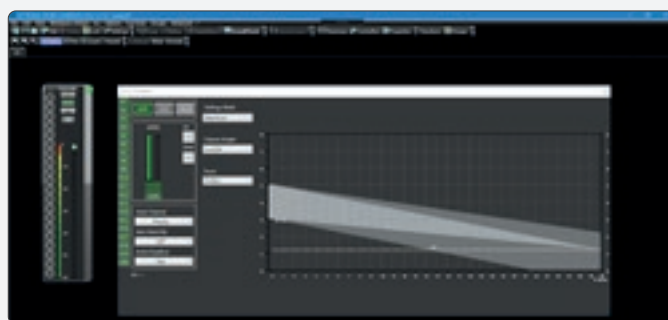

• "EASY FOCUS" CONFIGURATION

Simple, easy and suitable for all systems, advisable for users and installers that are not so experienced. Only two parameters are necessary: the loudspeaker installation height and the maximum distance to be covered.

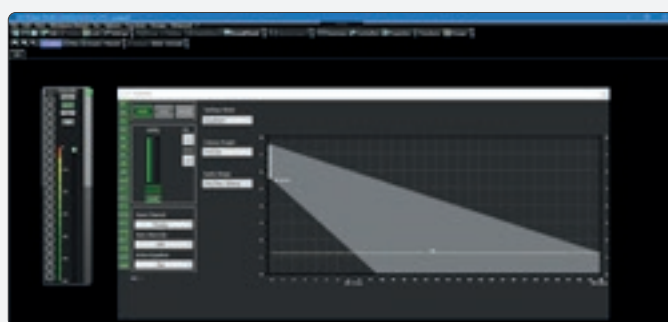

• "EASY BEAM" CONFIGURATION

For experts/installers, it allows the (virtual) setting of both loudspeakers tilt and beam

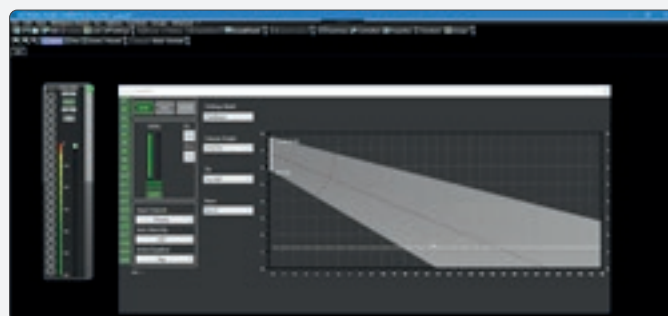

• "FREE BEAM" CONFIGURATION

Allows specifying the listening area to be covered by selecting a preset audio range.

HL SERIES

HL 2290 | HL 2260 | HL 2240

HORN LOADED ARRAY SYSTEM

HS 2200

ARRAY SUBWOOFER

The HL 2260 (2240, 2290) is a horn loaded two-way full range array system that incorporates a 2 x 12" woofer and a 1.4" exit 4.0" voice coil titanium compression driver for mid distance and long throw applications. The system is very compact and provides very high output and accurate voice and sound reproduction. The system is equipped with the latest generation of RCF precision transducers. The system has a vertical dispersion of 22.5° and is ideally used in point source configuration for mid distance applications or can be clustered with narrower angles for long throw applications. The loudspeaker enclosure shape is trapezoidal and offers a 22.5° coupling angle each side. Connections to the amplifier are made through a watertight Amphenol multi-pole connector.

- Horn Loaded two-way Array System
- Fully Horn-loaded, 60° x 22.5° (40° x 22.5°, 90° x 22.5°) directivity
- 2 x 12" RCF Precision woofers with 3.5" voice coil
- RCF Precision 4.0" voice coil compression driver, titanium dome
- 141 dB Max SPL
- Horn loading on RCF waveguide
- System Power rating 1500 W RMS (1350 W LF, 150 W HF)
- Safe and solid variable array mechanics
- Baltic Birch Plywood enclosure with internal structural metal bracings

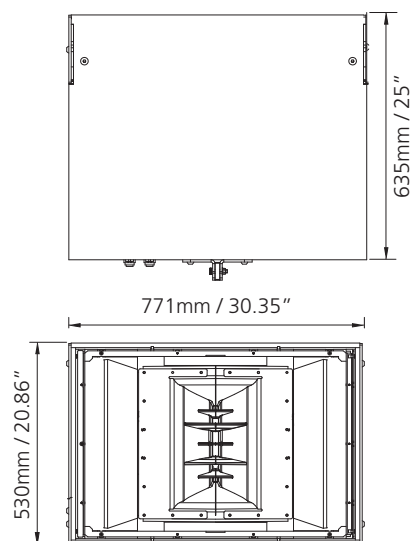

APPLICATIONS

- Outdoor Sound Reinforcement
- High-Level AV Playback
- Flown cluster configurations
- Large speech systems
- Music Sound Reinforcement



SPECIFICATIONS

HL 2290

p.n.130.00.405

HL 2260

p.n.130.00.407

HL 2240

p.n.130.00.404

HS 2200

p.n.130.00.406

ACOUSTICAL

FREQ. RANGE (-10 dB):	60 Hz ÷ 20 kHz	60 Hz ÷ 20 kHz	60 Hz ÷ 20 kHz	30 Hz ÷ 200 Hz
FREQ. RANGE (-3 dB):	80 Hz ÷ 20 kHz	80 Hz ÷ 20 kHz	80 Hz ÷ 20 kHz	35 Hz ÷ 200 Hz
HORIZ. COVERAGE ANGLE (-6 dB):	90°	60°	40°	-
VERTICAL COVERAGE ANGLE (-6 dB):	22.5°	22.5°	22.5°	-
DIRECTIVITY FACTOR Q:	13	14	16	-
SYSTEM SENSITIVITY:	LF 104 dB HF 113 1W @ 1m ⁽¹⁾	LF 104 dB HF 113 1W @ 1m ⁽¹⁾	LF 104 dB HF 113 1W @ 1m ⁽¹⁾	100 dB 1W @ 1m ⁽¹⁾
RATED MAXIMUM SPL:	141 dB, @ 1m	141 dB, @ 1m	141 dB, @ 1m	136 dB, @1m
SYSTEM NOMINAL IMPEDANCE:	8 ohm	8 ohm	8 ohm	-
SYSTEM INPUT POWER RATING RMS:	LF 1350 W, HF 150 W ⁽²⁾	LF 1350 W, HF 150 W ⁽²⁾	LF 1350 W, HF 150 W ⁽²⁾	LF 900 W ⁽²⁾
SYSTEM INPUT POWER RATING PEAK:	LF 5400 W, HF 600 W	LF 5400 W, HF 600 W	LF 5400 W, HF 600 W	LF 3600 W
RECOMMENDED AMPLIFIER:	LF 2700 W, HF 300 W	LF 2700 W, HF 300 W	LF 2700 W, HF 300 W	LF 1800 W
CROSSOVER:	Recommended 600 Hz	Recommended 600 Hz	Recommended 600 Hz	-

TRANSDUCERS

LOW FREQUENCY:	2 x 12" woofer, 3.5" v.c.	2 x 12" woofer, 3.5" v.c.	2 x 12" woofer, 3.5" v.c.	18" woofer 4.0" v.c.
NOMINAL IMPEDANCE:	8 ohm	8 ohm	8 ohm	8 ohm
INPUT POWER RATING:	1350 W AES	1350 W AES	1350 W AES	900 W AES
SENSITIVITY:	104 dB, 1W @ 1m	104 dB, 1W @ 1m	104 dB, 1W @ 1m	100 dB, 1W @ 1m
HIGH FREQUENCY:	neo 1.4" throat, 4" v.c.	neo 1.4" throat, 4" v.c.	neo 1.4" throat, 4" v.c.	-
INPUT POWER RATING:	150 W AES	150 W AES	150 W AES	-
SENSITIVITY:	113 dB, 1W @ 1m	113 dB, 1W @ 1m	113 dB, 1W @ 1m	-

PHYSICAL

ENCLOSURE:	Trapezoidal, 15 mm birch plywood construction			
RIGGING INSERTS:	Side and rear array rigging point			
COLOR:	Polyurea Black, weather and scratch resistant paint			
GRILLE:	Custom perforated steel grille			
INPUT CONNECTORS:	Amphenol eco/mat IP 67			
DIMENSIONS (H x W x D):	20.87" x 30.35" x 25.00" 530 x 771 x 635 mm			
WEIGHT:	69 kg	66 kg	69 kg	50.8 kg

1) Measured on axis in the far field with 1 watt (2.83V RMS, 8 ohm) input and referenced to 1 meter distance using the inverse square law. Listed sound pressure represents an average from 300 Hz to 3 kHz.

2) Using 20 Hz to 20 kHz, Pink Noise Spectrum, 2 hours, + 6 dB crest factor, with RMS voltage calculated on speaker minimum impedance.

3) Recommended Amplifier is a power capability value that should be taken as a guide.

HL SERIES

HL 2290 | HL 2260 | HL 2240

HORN LOADED ARRAY SYSTEM

HS 2200

ARRAY SUBWOOFER



The system is fully horn-loaded and it is ideally used either in point source configuration for mid distances or clustered with narrower angles for long-throw applications.



/ LOW FREQUENCY

The HL 2260 (2240, 2290) is a 2 x 12" woofer and a 2.0" exit with 3.5" voice-coil.

The HS 2200 is a 18" high-efficiency 4.0" voice-coil woofer with Inside/Outside Coil Technology.



/ HIGH FREQUENCY

The HL 2260 (2240, 2290) is a 4" compression driver with a 1.5" exit throat.

ARRAY FITTINGS

The HL SYSTEM is equipped with standard array fittings and IP 55 weather protection.



The cabinet is constructed of multi-ply Baltic birch marine plywood and finished in a very resistant, textured, polyurea black paint. The cabinet is equipped with 12 x M 8 brass inserts, a stainless steel U-Bracket and pair of spacers for 90° mounting.



The grille is in custom perforated aluminium with open-cell fibres and water repellent woven fabric backing.



HL 2290

RESPONSE 1W/1m

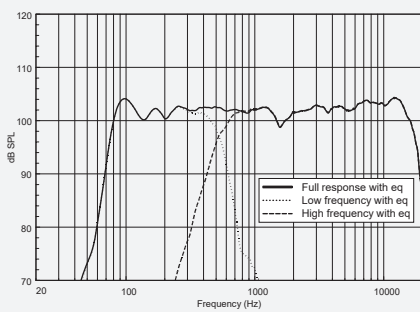

BEAMWIDTH vs. FREQUENCY

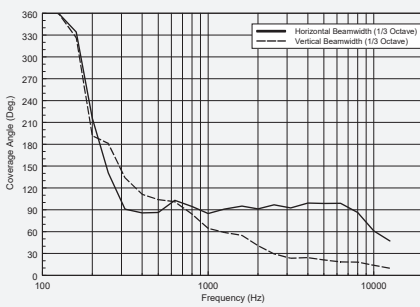

DIRECTIVITY INDEX AND Q

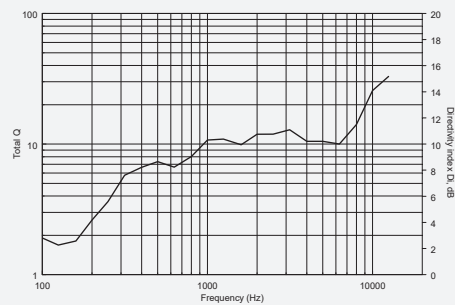

HL 2260

RESPONSE 1W/1m

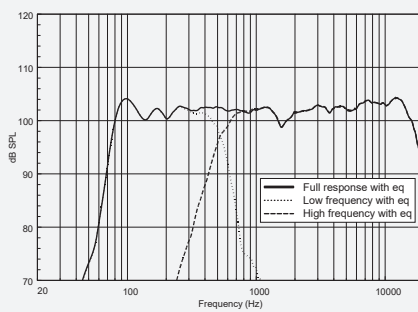

BEAMWIDTH vs. FREQUENCY

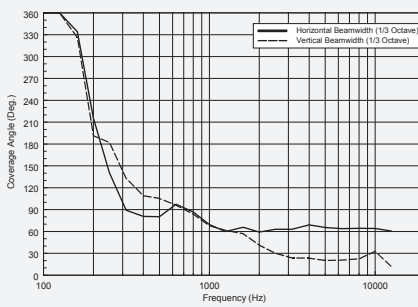

DIRECTIVITY INDEX AND Q

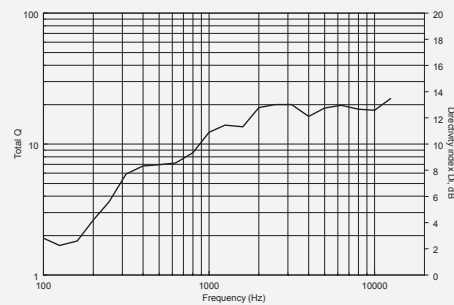

HL 2240

RESPONSE 1W/1m

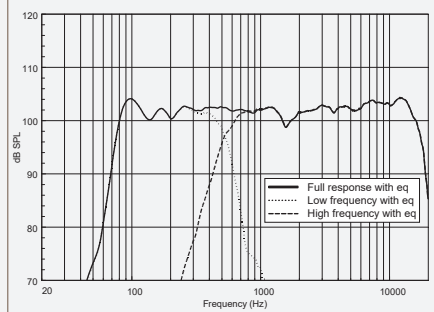

BEAMWIDTH vs. FREQUENCY

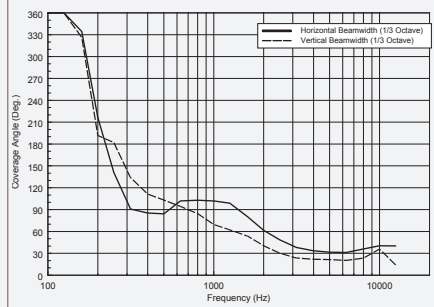

DIRECTIVITY INDEX AND Q

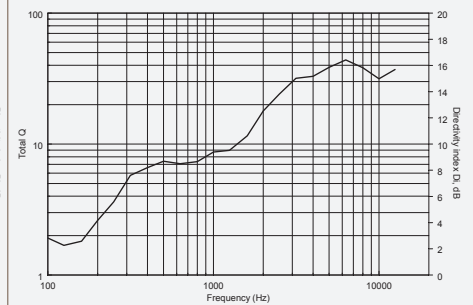

HS 2200

RESPONSE 1W/1m

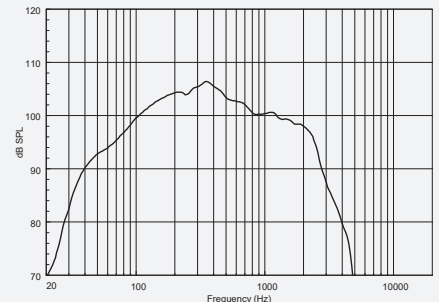

RELATED ACCESSORIES



FL-B HL

(p.n. 133.60.282)

Suspending bar for HL line array system

- To suspend HL 2240, HL 2260, HL 2290, HS 2200
- Strong steel construction

HL SERIES

HL 20-WP

WEATHERPROOF PASSIVE LINE ARRAY MODULE

The HL 20 WP is a compact, wide dispersion, 2 way passive line array module that offers the highest performance from a small size line array. The incredible high output and dynamics, the extreme accuracy and high frequency extension plus the compact size makes the HL 20 WP the ideal tool for outdoor sound reinforcement, live performances and events as well as fixed installations in theatres, concert halls or auditoriums. Connections to the amplifier are made through a watertight multi-pole connector. The grille is in custom perforated aluminum with open-cell fibers and water repellent woven fabric backing. The cabinet is constructed of multiply baltic birch plywood and finished in a fire resistant, textured coating.

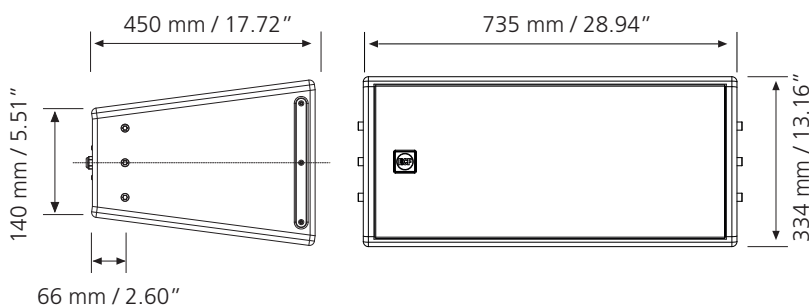

/ HIGH FREQUENCIES

The ND840 large format compression driver delivers one of the key advantages of the HL20 WP. The 3" voice coil allows a crossover point of 800Hz, therefore almost all of the vocal range can be produced by this driver. This allows better coverage, dispersion control, and superior efficiency.

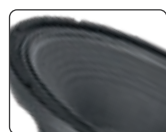

/ LOW FREQUENCIES

Water resistant fibre doped cone
Polycotton M-roll surround
High power magnetic structure

- Very compact size
- Maximum output per size available on the market
- Wide, constant directivity, horizontal coverage angle
- Minimum weight
- Watertight multi-pole connector IP67
- Baltic birch cabinet





SPECIFICATIONS

HL 20-WP

p.n. 130.00.473

ACOUSTICAL

FREQ. RANGE (-10 dB):	55 Hz ÷ 20 kHz
FREQ. RANGE (-3 dB):	65 Hz ÷ 20 kHz
HORIZ. COVERAGE ANGLE (-6 dB):	100°
VERTICAL COVERAGE ANGLE (-6 dB):	15°
DIRECTIVITY FACTOR Q:	16
SYSTEM SENSITIVITY:	102 dB, 1W @ 1m ⁽¹⁾
RATED MAXIMUM SPL:	135 dB, @ 1m
SYSTEM NOMINAL IMPEDANCE:	16 ohm
SYSTEM INPUT POWER RATING RMS:	LF 700 W, HF 100 W ⁽²⁾
SYSTEM INPUT POWER RATING PEAK:	LF 2800 W, HF 400 W
RECOMMENDED AMPLIFIER:	LF 1400 W, HF 200 W ⁽³⁾
CROSSOVER:	Recommended 800 Hz

TRANSDUCERS

LOW FREQUENCY:	2 x 10" (254 mm) woofer 2.5" (64 mm) coil
NOMINAL IMPEDANCE:	16 ohm
INPUT POWER RATING:	600 W AES
SENSITIVITY:	98 dB, 1W @ 1m
HIGH FREQUENCY:	neo 1.4" (38 mm) throat, 3" (75 mm) coil
NOMINAL IMPEDANCE:	16 ohm
INPUT POWER RATING:	110 W AES
SENSITIVITY:	109 dB, 1W @ 1m

PHYSICAL

ENCLOSURE:	Trapezoidal, 21 mm birch plywood construction
RIGGING INSERTS:	6 x Side M10 rigging points
COLOR:	White, Custom color, weather and scratch resistant paint
GRILLE:	Custom perforated stel grill with open cell poly fiber and waterproof cloth backing
INPUT CONNECTORS:	Amphenol eco/mat IP 67
DIMENSIONS (H x W x D):	13.14" x 28.93" x 17.71" 334 x 735 x 450 mm
WEIGHT:	74.95 lb 34 kg

RESPONSE 1W/1m

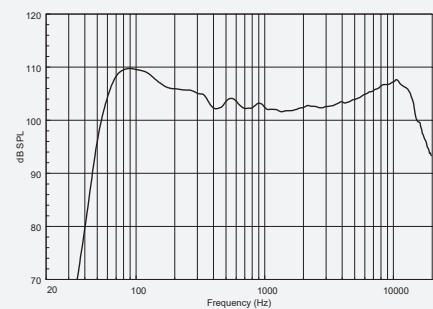

BEAMWIDTH vs. FREQUENCY

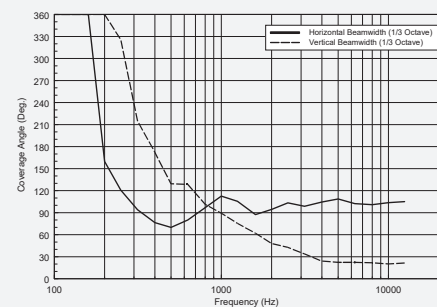

DIRECTIVITY INDEX AND Q

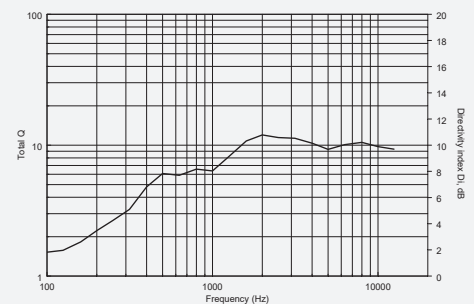

APPLICATIONS

- Outdoor sound reinforcement
- Touring sound reinforcement for mid-sized venues
- High quality reinforcement of music and speech
- Medium to large theatres and night clubs
- Stadiums, arenas, concert halls and other fixed venue installations
- Corporate A/V presentation

¹⁾ Measured on axis in the far field with 1 watt (2.83V RMS, 8 ohm) input and referenced to 1 meter distance using the inverse square law. Listed sound pressure represents an average from 300 Hz to 3 kHz.

²⁾ Using 20 Hz to 20 kHz, Pink Noise Spectrum, 2 hours, + 6 dB crest factor, with RMS voltage calculated on speaker minimum impedance.

³⁾ Recommended Amplifier is a power capability value that should be taken as a guide.

1315

H SERIES



H 1315

THREE WAY HORN LOADED SPEAKER SYSTEM

H 1315 WP

THREE WAY INDOOR/OUTDOOR HORN LOADED SPEAKER SYSTEM

The RCFACUSTICA H1315 and H 1315WP are three-way full range loudspeaker systems that incorporate a 15" LF transducer, a 10" cone MF transducer and a 1.4" exit titanium compression driver.

The MF cone driver is a unique RCF sealed basket design and is loaded into an exponential, Baltic birch 60° x 40° midrange horn. The 3" coil MF driver is acoustically equalized thanks to a unique RCF complex phase-plug design. The HF titanium compression driver is loaded on a constant directivity rotatable horn with a coverage of 60° x 40°.

The internal crossover network between midrange and compression driver offers a unique Compression Driver Protection thanks to an Active MOSFET Circuit. The system is driven in bi-amped mode, is able of producing a Max SPL higher than 136 dB and handles 900 W AES (LF) + 400 W AES (MF/HF). The loudspeaker enclosure shape is multi-trapezoidal and allow a double coupling angle each side. The cabinet of the H 1315 is constructed of multi-ply Baltic birch plywood and finished in a very resistant, textured, polyurethane black paint. The H1315WP cabinet is treated inside-outside with polyurea black paint. The cabinet includes 2 recessed handles for transportation and positioning and a total of six double M10 fixing point for flown applications and extensive internal metal bracing. The front steel grille is epoxy powder coated for H 1315 version and equipped with two layers of weather-resistant open-cell fibres and water repellent woven fabric backing for WP version. The transducer cones as well carry a special additional treatment to resist against critical environmental conditions. While standard version uses a SPEAKON connector, the H 1315 WP is equipped with an IP 67 removable Amphenol terminal.

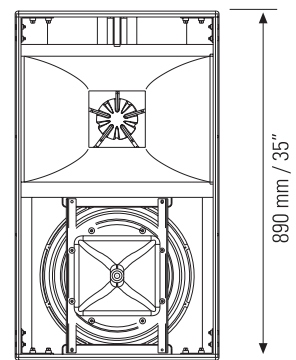
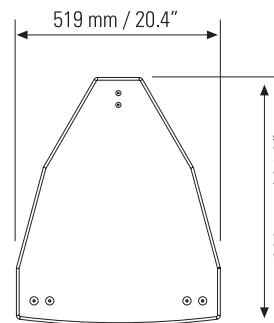

RELATED ACCESSORIES

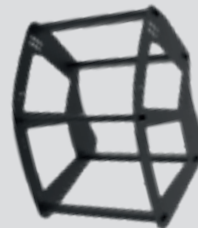

C-BR H 1315

(p.n. 331.83.006)
Cluster Flybar for 2 x H1315 or 2 x H1315 WP

SUGGESTED PROCESSOR

DX 4008

p.n. 121.35.033

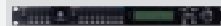

4 inputs, 8 output digital processor



- Compact Arrayable 3-way System
- Fully Horn-loaded LF/MF/HF (60° x 40° directivity)
- Fully equipped with Neodymium Transducers
- Bi-amp system (passive crossover MF/HF included)
- Active Mosfet Compression Driver Protection
- Rotable HF Horn
- Recessed handles



SPECIFICATIONS

H 1315

p.n.130.00.084

H 1315 WP

p.n. 130.00.266

ACOUSTICAL

FREQ. RANGE (-10 dB):	50 Hz ÷ 20 kHz
FREQ. RANGE (-3 dB):	65 Hz ÷ 20 kHz
HORIZ. COVERAGE ANGLE (-6 dB):	60°
VERTICAL COVERAGE ANGLE (-6 dB):	40°
DIRECTIVITY FACTOR Q:	12
SYSTEM SENSITIVITY:	LF 100 dB, HF/MF 108 dB 1W @ 1m ⁽¹⁾
RATED MAXIMUM SPL:	136 dB, @ 1m
SYSTEM NOMINAL IMPEDANCE:	8 ohm
SYSTEM INPUT POWER RATING RMS:	LF 900 W, HF/MF 400 W ⁽²⁾
SYSTEM INPUT POWER RATING PEAK:	LF 3600 W, HF/MF 1600 W
RECOMMENDED AMPLIFIER:	LF 1800 W, HF/MF 800 W ⁽³⁾
HF PROTECTION:	Active Mosfet compression driver
CROSSOVER:	Recommended 300 Hz, internal MF/HF 1300 Hz

TRANSDUCERS

LOW FREQUENCY:	neo 15" (381 mm) woofer 4" (100 mm) coil
NOMINAL IMPEDANCE:	8 ohm
INPUT POWER RATING:	900 W AES
SENSITIVITY:	100 dB, 1W @ 1m
MID FREQUENCY	neo 10" (254 mm) midrange 3" (76 mm) coil
NOMINAL IMPEDANCE	8 ohm
INPUT POWER RATING	300 W AES
SENSITIVITY	109 dB, 1W @ 1m
HIGH FREQUENCY	neo 1,4" (35,5 mm) throat 3" (75 mm) coil
NOMINAL IMPEDANCE	8 ohm
INPUT POWER RATING	110 W AES
SENSITIVITY	109 dB, 1W @ 1m

PHYSICAL

ENCLOSURE:	Double Trapezoidal, 15 mm birch plywood construction
RIGGING INSERTS:	12 x M10, rigging point
COLOR:	Black, scratch resistant paint (H1315WP inside-outside polyurea black paint)
GRILLE:	Custom perforated steel grille (H1315 WP epoxy powder coated, weather-resistant open-cell fibres and water repellent woven fabric backing)
INPUT CONNECTORS:	Speakon® NL4 (H1315 WP Amphenol eco mat IP67)
DIMENSIONS (H x W x D):	35.03" x 20.47" x 24.88" 890 x 520 x 632 mm
WEIGHT:	78.26 lb 35.5 kg

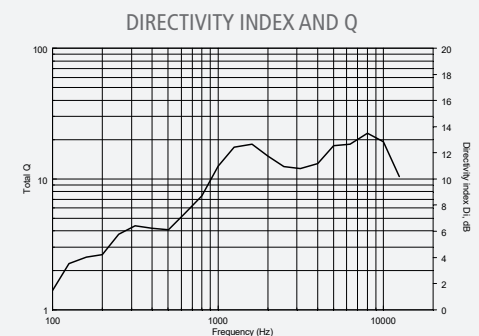
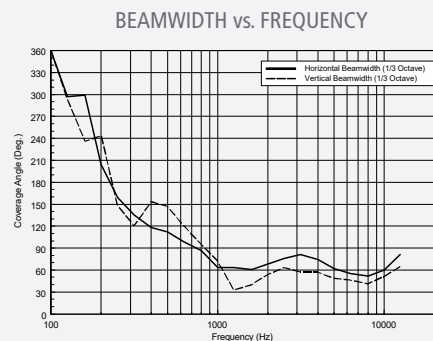
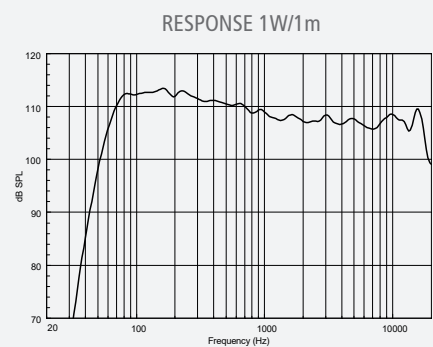

APPLICATIONS

- Permanent Installations
- Sound Reinforcement in medium to large spaces
- AV Presentations
- Flown Clusters
- Club Systems
- Main PA in mid to large-size systems

1) Measured on axis in the far field with 1 watt (2.83V RMS, 8 ohm) input and referenced to 1 meter distance using the inverse square law. Listed sound pressure represents an average from 300 Hz to 3 kHz.

2) Using 20 Hz to 20 kHz, Pink Noise Spectrum, 2 hours, + 6 dB crest factor, with RMS voltage calculated on speaker minimum impedance.

3) Recommended Amplifier is a power capability value that should be taken as a guide.

45

V MAX

V 45

HIGH POWER, TWO-WAY BASS REFLEX FULL RANGE SYSTEM

The V 45 is a two-way full range loudspeaker system that incorporates 2 x 15" LF transducers and a 4" voice coil, titanium, compression driver. The system is very compact and provides very high output and accurate voice and sound reproduction.

The 4.0" HF titanium compression driver is a state of the art in compression drivers designs and is loaded on a constant directivity horn with a perfect coverage of 90° x 40°.

The loudspeaker enclosure shape is trapezoidal and offers a coupling angle each side. The cabinet is constructed in multi-ply birch plywood and finished in a highly resistant, textured, polyurea black paint.

The cabinet includes two recessed handles for transportation and positioning and a total of six double M10 fixing point for flown applications with internal metal bracing.

The epoxy coated front steel grille features side mounted rubber dampeners and foam backing.

The cabinet features two Neutrik Speakon™ connectors in a recessed input plate. A 2-position high power selector sets the system in passive or bi-amped mode.

The high power internal passive filter provides crossover protection and equalisation.



SUGGESTED PROCESSOR

DX 4008

p.n. 121.35.033



4 inputs, 8 output digital processor

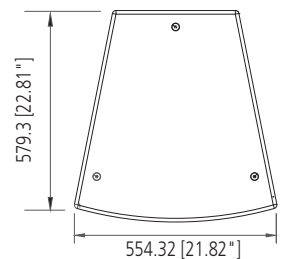
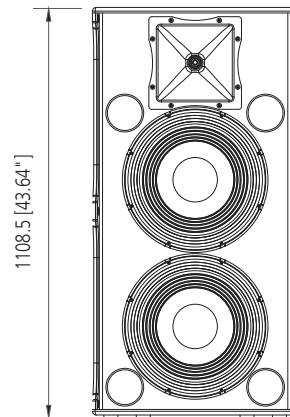

/ WOOFER

The low-frequency transducer is a high power 15" woofer with a 4" voice coil built in our factory in Italy using the most advanced assembly technologies.



/ COMPRESSION DRIVER

The CMD horn is loaded to a Neodymium compression driver with a 4" titanium diaphragm assembly for smooth, controlled dispersion.

- 2 x 15" high power, 4" voice coil hyperventated woofers
- 1 x 4" high power titanium neo compression driver
- 137 dB max SPL, 1800 W AES
- Very high output, response down to 30 Hz
- Birch plywood cabinet
- Whether resistant, textured, polyurea finish
- Epoxy powder coated front grille



SPECIFICATIONS

V 45

p.n. 130.00.413

ACOUSTICAL

FREQ. RANGE (-10 dB):	30 Hz ÷ 20 kHz
HORIZ. COVERAGE ANGLE (-6 dB):	90°
VERTICAL COVERAGE ANGLE (-6 dB):	40°
DIRECTIVITY FACTOR Q:	10
SYSTEM SENSITIVITY:	99 dB, 1W @ 1m ⁽¹⁾
RATED MAXIMUM SPL:	137 dB, @ 1m
SYSTEM NOMINAL IMPEDANCE:	4 ohm
SYSTEM INPUT POWER RATING RMS:	1800 W ⁽²⁾
SYSTEM INPUT POWER RATING PEAK:	7200 W
RECOMMENDED AMPLIFIER:	3600 W ⁽³⁾
HF PROTECTION:	Bulb Lamp
CROSSOVER:	1.2 kHz

TRANSDUCERS

LOW FREQUENCY:	2 x 15" woofer 4" voice coil
NOMINAL IMPEDANCE:	8 ohm
INPUT POWER RATING:	900 W AES; 1800 W Peak
SENSITIVITY:	97 dB, 1W @ 1m
HIGH FREQUENCY:	neo 1.4" driver 4" voice coil
NOMINAL IMPEDANCE:	8 ohm
INPUT POWER RATING:	140 W AES; 280 W Peak
SENSITIVITY:	110 dB, 1W @ 1m

PHYSICAL

ENCLOSURE:	15 mm Birch Plywood
RIGGING INSERTS:	12 x M10
COLOR:	Black
GRILLE:	Custom perforated steel grille
INPUT CONNECTORS:	2 x SPEAKON NL4
DIMENSIONS (H x W x D):	43.64" x 21.82" x 22.81" 1108.5 x 554.3 x 579.3 mm
WEIGHT:	137.7 lbs 62.5 kg

RESPONSE 1W/1m

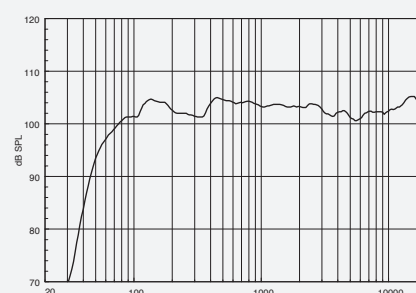

BEAMWIDTH vs. FREQUENCY

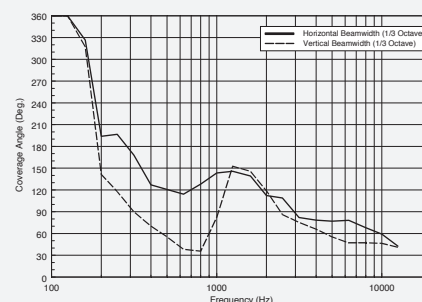

DIRECTIVITY INDEX AND Q

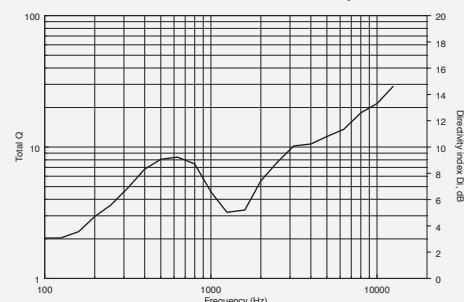

APPLICATIONS

- Live performance
- DJ set
- Rental solutions
- Permanent installations

1) Measured on axis in the far field with 1 watt (2.83V RMS, 8 ohm) input and referenced to 1 meter distance using the inverse square law. Listed sound pressure represents an average from 300 Hz to 3 kHz.

2) Using 20 Hz to 20 kHz, Pink Noise Spectrum, 2 hours, + 6 dB crest factor, with RMS voltage calculated on speaker minimum impedance.

3) Recommended Amplifier is a power capability value that should be taken as a guide.

V 35

V 35

HIGH POWER, TWO-WAY BASS REFLEX FULL RANGE SYSTEM

The V 35 is a full range, extremely versatile controlled dispersion two-way loudspeaker system. This offers substantial power and efficiency for a variety of professional applications that include portable systems, primary sound reinforcement, plus permanent installations and supplementary fill for larger systems. The high-frequency section is a constant directivity CMD horn mathematically designed for Constant Matching Design compared to the woofer system, loaded on a neodymium compression driver with a 3.0" titanium diaphragm assembly for smooth, controlled dispersion. The low-frequency transducer is a high power 15" woofer with a 4.0" voice coil.

The cabinet includes a recessed handle for transportation and positioning and a total of six double M10 fixing point for flown applications with internal metal bracing.

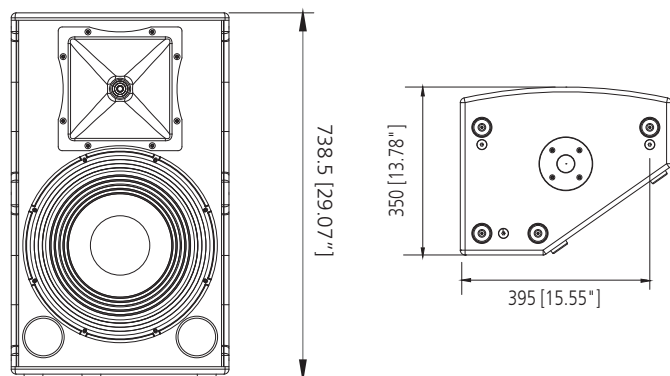

The epoxy coated front steel grille features side mounted rubber dampeners and foam backing.



STAGE MONITOR CONFIGURATION



SUGGESTED PROCESSOR

DX 4008

p.n. 121.35.033



4 inputs, 8 output digital processor



/ WOOFER

The low-frequency transducer is a high power 15" woofer with a 4.0" voice coil built in our factory in Italy using the most advanced assembly technologies.



/ COMPRESSION DRIVER

The CMD horn is loaded to a Neodymium compression driver with a 3.0" titanium diaphragm assembly for smooth, controlled dispersion.



The system includes a high-level crossover network that features markedly lower (than conventional) induction values in series with the woofer. The benefits are reduction in delay, reduced phase shift and superior transient response.

- 15" high power, 4" voice coil hyperventated woofers
- 1 x 3" high power titanium neo compression driver
- 132 dB max SPL, 900 W AES
- Very high output, response down to 40
- Birch plywood cabinet
- Weather resistant, textured, polyurea
- Epoxy powder coated front grille



SPECIFICATIONS

V 35

p.n. 130.00.412

ACOUSTICAL

FREQ. RANGE (-10 dB):	40 Hz ÷ 20 kHz
HORIZ. COVERAGE ANGLE (-6 dB):	90°
VERTICAL COVERAGE ANGLE (-6 dB):	40°
DIRECTIVITY FACTOR Q:	10
SYSTEM SENSITIVITY:	97 dB, 1W @ 1m ⁽¹⁾
RATED MAXIMUM SPL:	132 dB, @ 1m
SYSTEM NOMINAL IMPEDANCE:	8 ohm
SYSTEM INPUT POWER RATING RMS:	900 W ⁽²⁾
SYSTEM INPUT POWER RATING PEAK:	3600 W
RECOMMENDED AMPLIFIER:	1800 W ⁽³⁾
HF PROTECTION:	Bulb Lamp
CROSSOVER:	1.4 kHz

TRANSDUCERS

LOW FREQUENCY:	15" woofer 4" voice coil
NOMINAL IMPEDANCE:	8 ohm
INPUT POWER RATING:	900 W AES; 1800 W Peak
SENSITIVITY:	97 dB, 1W @ 1m
HIGH FREQUENCY:	neo 1.4" driver 3" voice coil
NOMINAL IMPEDANCE:	8 ohm
INPUT POWER RATING:	110 W AES; 220 W Peak
SENSITIVITY:	109 dB, 1W @ 1m

PHYSICAL

ENCLOSURE:	15 mm Birch Plywood
RIGGING INSERTS:	Pole mount, 10 x M10
COLOR:	Black
GRILLE:	Custom perforated steel grille
INPUT CONNECTORS:	2 x SPEAKON NL4
DIMENSIONS (H x W x D):	29.07" x 17.32" x 13.78" 738.5 x 440 x 350 mm
WEIGHT:	68.3 lbs 31 kg

RESPONSE 1W/1m

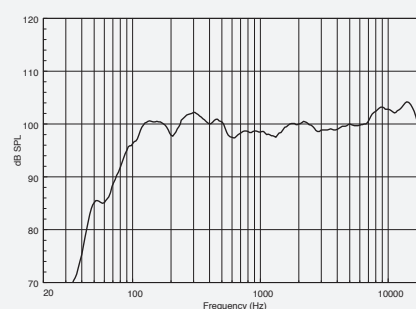

BEAMWIDTH vs. FREQUENCY

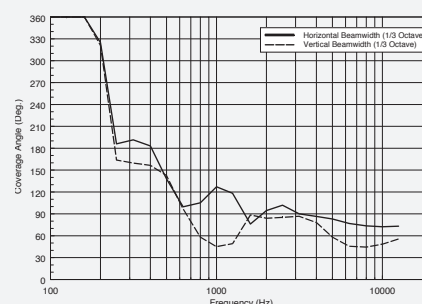

DIRECTIVITY INDEX AND Q

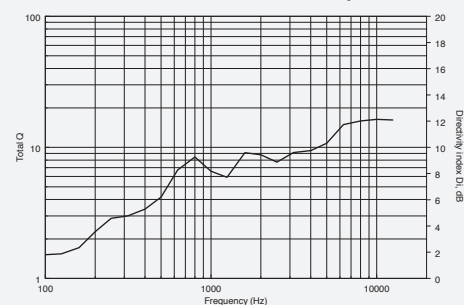

APPLICATIONS

- Live performance
- DJ set
- Rental solutions
- Permanent installations

1) Measured on axis in the far field with 1 watt (2.83V RMS, 8 ohm) input and referenced to 1 meter distance using the inverse square law. Listed sound pressure represents an average from 300 Hz to 3 kHz.

2) Using 20 Hz to 20 kHz, Pink Noise Spectrum, 2 hours, + 6 dB crest factor, with RMS voltage calculated on speaker minimum impedance.

3) Recommended Amplifier is a power capability value that should be taken as a guide.

V10

V MAX

V 10

HIGH POWER, TWO-WAY BASS REFLEX FULL RANGE SYSTEM

The V 10 is a compact, full range, extremely versatile two-way loudspeaker system. It offers substantial power and efficiency for a variety of professional applications that include portable systems, sound reinforcement, permanent installations and supplementary fill for larger systems. The high-frequency section is a constant directivity CMD horn mathematically designed for Constant Matching Design in relation to the woofer system, loaded on a neodymium compression driver with a 2.5" diaphragm assembly for smooth, controlled dispersion. The low-frequency transducer is a tight, high power 10" mid-bass with a 2.5" voice coil.

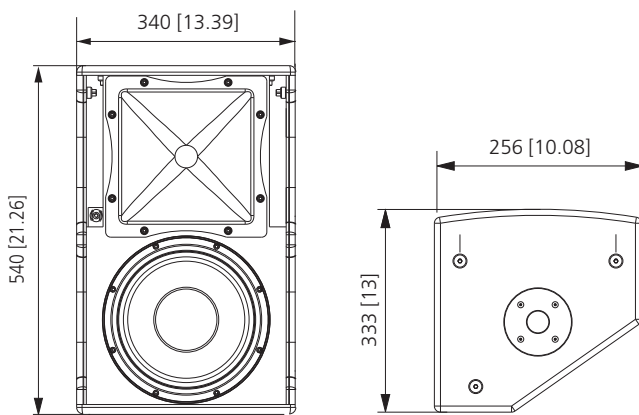

/ CONNECTIONS

Connections are made through two Neutrik Speakon NL4 connectors (audio input and parallel link output).



/ HEAVY DUTY POLYUREA PAINT

The paint department inside our factory in Italy utilizes a special polyurea paint to create a very thick full coating of the cabinet making it highly resistant to scratches and bumps.



/ COMPRESSION DRIVER

The V10 features a high performance 2.5" diaphragm compression driver with a 1.4" exit throat. The diaphragm is precision formed from titanium. The voice coil assembly is designed using high temperature Kapton

former, rectangular profile copper clad aluminium wire and assembled using advanced, specially formulated adhesives.



- 10" high power, 2.5" voice coil mid bass
- 2.5" high power titanium compression driver
- 130 dB max SPL
- 350 W AES
- High output, response down to 60 Hz
- Birch plywood cabinet
- Weather resistant, textured, polyurea finish
- Epoxy powder coated front grille



SPECIFICATIONS

V 10

p.n.130.00.438

ACOUSTICAL

FREQ. RANGE (-10 dB):	55 Hz ÷ 20 kHz
HORIZ. COVERAGE ANGLE (-6 dB):	90°
VERTICAL COVERAGE ANGLE (-6 dB):	60°
DIRECTIVITY FACTOR Q:	10
SYSTEM SENSITIVITY:	98 dB, 1W @ 1m ⁽¹⁾
RATED MAXIMUM SPL:	130 dB, @ 1m
SYSTEM NOMINAL IMPEDANCE:	8 ohm
SYSTEM INPUT POWER RATING RMS:	350 W ⁽²⁾
SYSTEM INPUT POWER RATING PEAK:	1400 W
RECOMMENDED AMPLIFIER:	700 W ⁽³⁾
HF PROTECTION:	Dynamic
CROSSOVER:	1.0 KHz

TRANSDUCERS

LOW FREQUENCY:	10" woofer 2.5" voice coil
NOMINAL IMPEDANCE:	8 ohm
INPUT POWER RATING:	250 W AES; 500 W Peak
SENSITIVITY:	98 dB, 1W @ 1m
HIGH FREQUENCY:	neo 1.4" driver 2.5" voice coil
NOMINAL IMPEDANCE:	8 ohm
INPUT POWER RATING:	90 W AES; 180 W Peak
SENSITIVITY:	110 dB, 1W @ 1m

PHYSICAL

ENCLOSURE:	15 mm Birch Plywood
RIGGING INSERTS:	Pole mount
COLOR:	Black
GRILLE:	Custom perforated steel grille
INPUT CONNECTORS:	2 x SPEAKON NL4
DIMENSIONS (H x W x D):	21.26" x 13.39" x 13.11" 540 x 340 x 333 mm
WEIGHT:	39.02 lbs 17.7 kg

RESPONSE 1W/1m

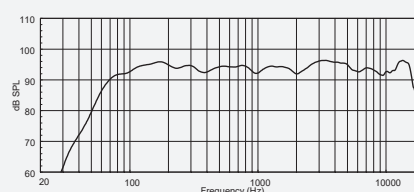

BEAMWIDTH vs. FREQUENCY

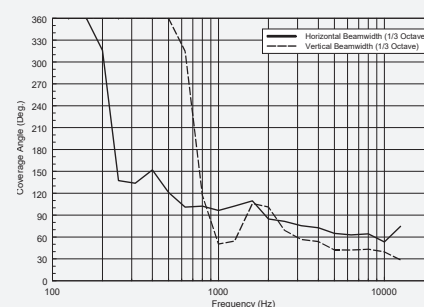

DIRECTIVITY INDEX AND Q

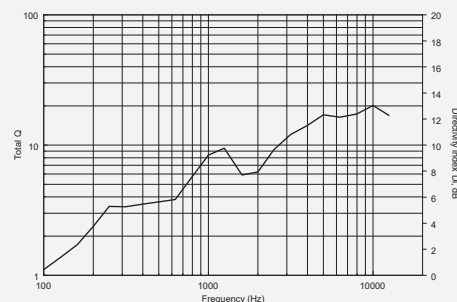

APPLICATIONS

- Live performance
- DJ set
- Rental solutions
- Permanent installations
- Portable systems
- Supplementary fill for larger systems

1) Measured on axis in the far field with 1 watt (2.83V RMS, 8 ohm) input and referenced to 1 meter distance using the inverse square law. Listed sound pressure represents an average from 300 Hz to 3 kHz.

2) Using 20 Hz to 20 kHz, Pink Noise Spectrum, 2 hours, + 6 dB crest factor, with RMS voltage calculated on speaker minimum impedance.

3) Recommended Amplifier is a power capability value that should be taken as a guide.

V MAX

V 6

HIGH POWER, TWO-WAY BASS REFLEX FULL RANGE SYSTEM

The V 6 is a very compact, full range, extremely versatile two-way loudspeaker system. It offers substantial output and efficiency for a variety of professional applications that include portable systems, small sound reinforcement, permanent installations and supplementary fill for larger systems. The high-frequency section is a constant directivity CMD horn mathematically designed for Constant Matching Design in relation to the woofer system, loaded on a compression driver with a 1.7" diaphragm assembly for smooth, controlled dispersion. The low-frequency transducer is a tight, high power 6" mid-bass with a 1.8" voice coil.

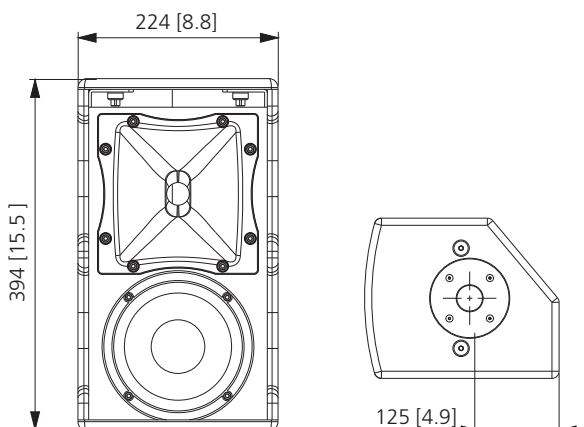

/ CABINET

Is built in baltic birch plywood, coated with high resistance polyurea paint and features a steel pole mount cap and rear mounting M10 points. The side is designed with an angle for near field monitoring or under-balcony applications.

STAGE MONITOR CONFIGURATION



/ WOOFER

The V 6 woofer is a new design featuring 1.7" aluminum voice coil, high excursion, handling 200 watt AES power. The cone is weather protected for long lasting installations.



/ COMPRESSION DRIVER

The V 6 features a high performance 1.75" diaphragm compression driver with a 1.0" exit throat.

The diaphragm is precision formed from polyester. The voice coil assembly is designed using high temperature Kapton former, rectangular profile copper clad aluminium wire and assembled using advanced, specially formulated adhesives.



- 6" high power, 1.7" voice coil mid bass
- 1 x 1.7" high power titanium compression driver
- 123 dB max SPL
- 200 W AES
- High output, response down to 60 Hz
- Birch plywood cabinet
- Weather resistant, textured, polyurea finish
- Epoxy powder coated front grille



SPECIFICATIONS

V 6

p.n.130.00.437

ACOUSTICAL

FREQ. RANGE (-10 dB):	60 Hz ÷ 20 kHz
HORIZ. COVERAGE ANGLE (-6 dB):	90°
VERTICAL COVERAGE ANGLE (-6 dB):	60°
DIRECTIVITY FACTOR Q:	10
SYSTEM SENSITIVITY:	94 dB, 1W @ 1m ⁽¹⁾
RATED MAXIMUM SPL:	123 dB, @ 1m
SYSTEM NOMINAL IMPEDANCE:	8 ohm
SYSTEM INPUT POWER RATING RMS:	200 W ⁽²⁾
SYSTEM INPUT POWER RATING PEAK:	800 W
RECOMMENDED AMPLIFIER:	400 W ⁽³⁾
HF PROTECTION:	Dynamic
CROSSOVER:	1.2 KHz

TRANSDUCERS

LOW FREQUENCY:	6" woofer 1.7" voice coil
NOMINAL IMPEDANCE:	8 ohm
INPUT POWER RATING:	90 W AES; 180 W Peak
SENSITIVITY:	94 dB, 1W @ 1m
HIGH FREQUENCY	1.0" driver 1.75" voice coil
NOMINAL IMPEDANCE	8 ohm
INPUT POWER RATING	180 W AES; 360 W Peak
SENSITIVITY	108 dB, 1W @ 1m

PHYSICAL

ENCLOSURE:	15 mm Birch Plywood
RIGGING INSERTS:	Pole mount, 10 x M10
COLOR:	Black
GRILLE:	Custom perforated steel grille
INPUT CONNECTORS:	2 x SPEAKON NL4
DIMENSIONS (H x W x D):	15.5" x 8.8" x 10.7" 394 x 224 x 272 mm
WEIGHT:	19.84 lbs 9 kg

RESPONSE 1W/1m

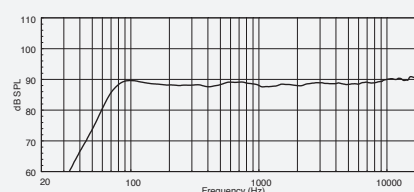

BEAMWIDTH vs. FREQUENCY

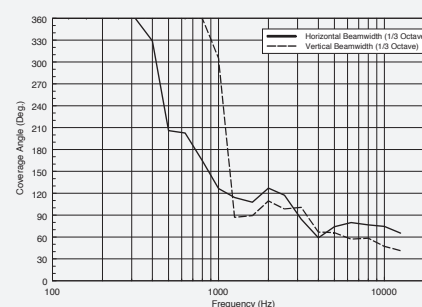

DIRECTIVITY INDEX AND Q

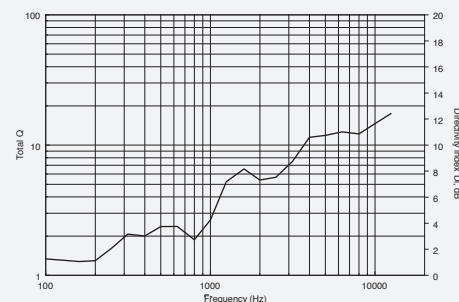

APPLICATIONS

- Live performance
- DJ set
- Rental solutions
- Permanent installations
- Portable systems
- Supplementary fill for larger systems

1) Measured on axis in the far field with 1 watt (2.83V RMS, 8 ohm) input and referenced to 1 meter distance using the inverse square law. Listed sound pressure represents an average from 300 Hz to 3 kHz.

2) Using 20 Hz to 20 kHz, Pink Noise Spectrum, 2 hours, + 6 dB crest factor, with RMS voltage calculated on speaker minimum impedance.

3) Recommended Amplifier is a power capability value that should be taken as a guide.

V MAX 21

V 221-S

HIGH POWER, BASS REFLEX SUBWOOFER SYSTEM

The V 221-S is a very high-output bass reflex subwoofer. The system is equipped with two advanced 21" RCF precision woofers mounted in a front-loaded configuration. This new high power design marks the latest refinements in RCF experience in compact subwoofer design, resulting in a fast and controlled reproduction of the bass frequency range. The two transducers couple to achieve tight and maximised output, while the subwoofer design ensures an efficient acoustic response down to 25 Hz.

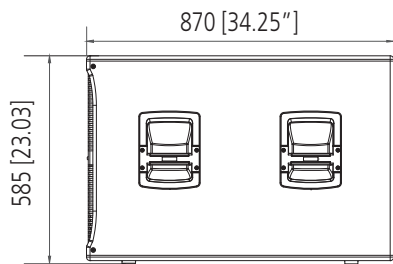
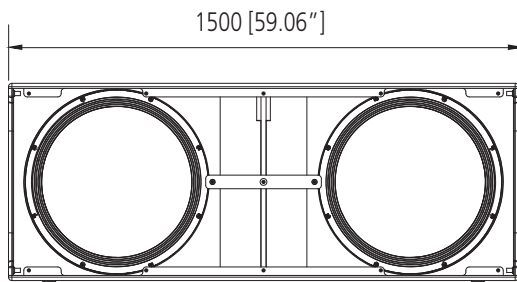

The LF21X451 features a fibre loaded cone assembly along with a high excursion triple roll, constant geometry surround: this combination provides remarkable strength and a peak to peak maximum excursion of 54 mm.

The new dual forced hyper-venting system guarantees a very efficient voice coil ventilation for minimum power compression and the 2000 W AES incredible power handling.



Equipped in V 221-S, the LF21X451 low frequency transducer is the result of many years of developments with the goal of creating new levels of professional audio performance standards.

Incredibly linear frequency response characteristics, the highest power handling of any comparable transducer and the lowest power compression.

- 2 x 21" high power, 4.5" voice coil hypervented woofers
- 143 dB max SPL
- 4000 W AES
- Very high output, response down to 30 Hz
- Birch plywood cabinet
- Weather resistant, textured, polyurea finish
- Epoxy powder coated front grille





SPECIFICATIONS

V 221-S

p.n. 130.00.415

ACOUSTICAL

FREQ. RANGE (-10 dB)	25 Hz ÷ 200 Hz
SYSTEM SENSITIVITY	100 dB, 1W @ 1m ⁽¹⁾
RATED MAXIMUM SPL	143 dB, @ 1m
SYSTEM NOMINAL IMPEDANCE	4 ohm
SYSTEM INPUT POWER RATING RMS	4000 W ⁽²⁾
SYSTEM INPUT POWER RATING PEAK	16000 W
RECOMMENDED AMPLIFIER	8000 W ⁽³⁾

TRANSDUCERS

LOW FREQUENCY	2 x 21" woofer 4.5" voice coil
NOMINAL IMPEDANCE	8 ohm
INPUT POWER RATING	2000 W AES, 4000 W PEAK

PHYSICAL

ENCLOSURE:	Rectangular, 15 mm birch plywood
RIGGING INSERTS:	Pole mount
COLOR:	Black, scratch resistant paint
GRILLE:	Custom perforated steel grille
INPUT CONNECTORS:	2 x SPEAKON NL4
DIMENSIONS (H x W x D):	22.406" x 47.24" x 29.33" 585 x 1500 x 870 mm
WEIGHT:	242,50 lbs 110 kg

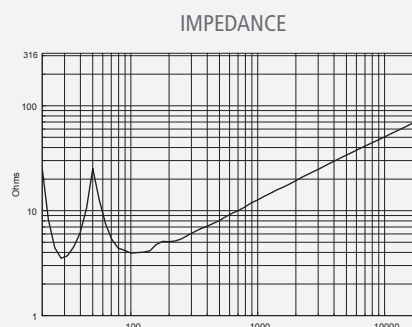

APPLICATIONS

- Live performance
- DJ set
- Rental solutions
- Permanent installations



The cabinet features two Neutrik Speakon™ connectors in a recessed input plate.

A 2-position high power selector set the transducers in parallel or independent input mode.

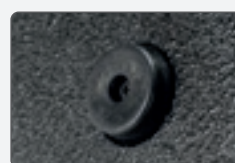

The epoxy coated front steel grille features side mounted rubber dampeners and foam backing.

The loudspeaker enclosure shape is rectangular and the cabinet is constructed in multi-ply birch plywood and finished in a weather-resistant, textured, polyurea black paint. It features four side handles and rubber feet.

1) Measured on axis in the far field with 1 watt (2.83V RMS, 8 ohm) input and referenced to 1 meter distance using the inverse square law. Listed sound pressure represents an average from 300 Hz to 3 kHz.
 2) Using 20 Hz to 20 kHz, Pink Noise Spectrum, 2 hours, + 6 dB crest factor, with RMS voltage calculated on speaker minimum impedance.
 3) Recommended Amplifier is a power capability value that should be taken as a guide.

218

V MAX

V 218-S

HIGH POWER, BASS REFLEX SUBWOOFER SYSTEM

The V 218-S is a compact, high-output bass reflex subwoofer. The system is equipped with two advanced neodymium 18" RCF precision woofers mounted in a front-loaded configuration.

This new high power design marks the latest refinements in RCF experiences in compact subwoofer design, resulting in a fast and controlled reproduction of the bass frequency range. The two transducers couple to achieve tight and maximised output, while the subwoofer design ensures an efficient acoustic response down to 30 Hz.

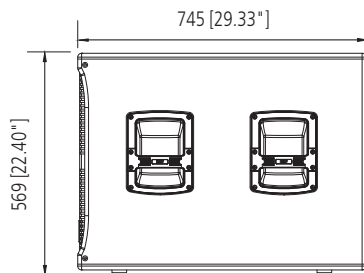
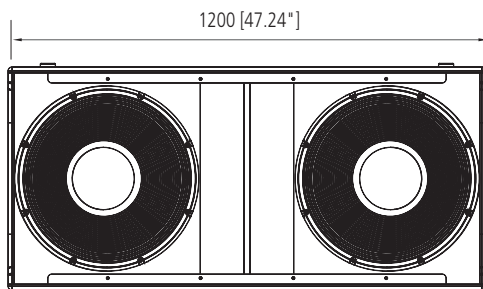

The loudspeaker enclosure shape is rectangular and the cabinet is constructed in multi-ply birch plywood and finished in a weather-resistant, textured, polyurea black paint.

It features four side handles and rubber feet. The epoxy coated front steel grille features side mounted rubber dampeners and foam backing.



The low-frequency transducer is a hyperventilated vented, high excursion RCF Precision 18" woofer with a 4" inside/outside voice coil to minimize power compression and extend the life of the product.

- 2 x 18" high power, 4" voice coil hyperventilated woofers
- 141 dB max SPL, 3000 W AES
- Very high output, response down to 30 Hz
- Birch plywood cabinet
- Weather resistant, textured, polyurea finish
- Epoxy powder coated front grille





SPECIFICATIONS

V 218-S

p.n. 130.00.414

ACOUSTICAL

FREQ. RANGE (-10 dB)	30 Hz ÷ 250 kHz
SYSTEM SENSITIVITY	99 dB , 1W @ 1m ⁽¹⁾
RATED MAXIMUM SPL	141 dB , @ 1m
SYSTEM NOMINAL IMPEDANCE	4 ohm
SYSTEM INPUT POWER RATING RMS	3000 W ⁽²⁾
SYSTEM INPUT POWER RATING PEAK	12000 W
RECOMMENDED AMPLIFIER	6000 W ⁽³⁾
PROTECTIONS	Weather

TRANSDUCERS

LOW FREQUENCY	2 x 18" woofer 4" voice coil
NOMINAL IMPEDANCE	8 ohm
INPUT POWER RATING	3000 W AES, 6000 W PEAK

PHYSICAL

ENCLOSURE:	Rectangular, 15 mm birch plywood
RIGGING INSERTS:	Pole mount
COLOR:	Black, scratch resistant paint
GRILLE:	Custom perforated steel grille
INPUT CONNECTORS:	2 x SPEAKON NL4
DIMENSIONS (H x W x D):	22.406" x 47.24" x 29.33" 569 x 1200 x 745 mm
WEIGHT:	172 lbs 78 kg

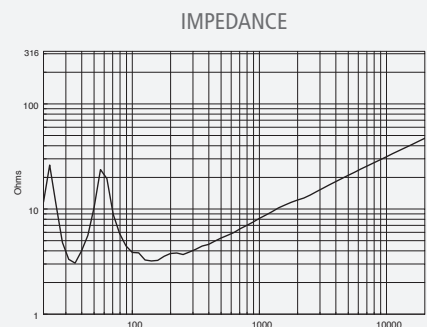
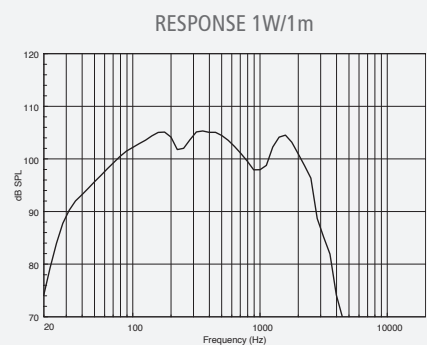

APPLICATIONS

- Live performance
- DJ set
- Rental solutions
- Permanent installations



The cabinet features two Neutrik Speakon™ connectors in a recessed input plate.

A 2-position high power selector set the transducers in parallel or independent input mode.



1) Measured on axis in the far field with 1 watt (2.83V RMS, 8 ohm) input and referenced to 1 meter distance using the inverse square law. Listed sound pressure represents an average from 300 Hz to 3 kHz.

2) Using 20 Hz to 20 kHz, Pink Noise Spectrum, 2 hours, + 6 dB crest factor, with RMS voltage calculated on speaker minimum impedance.

3) Recommended Amplifier is a power capability value that should be taken as a guide.

4112

C MAX

C MAX 4112

FULL RANGE HIGH POWER NEARFIELD SPEAKER

The full-range passive two-way speaker RCF C MAX 4112 has been specifically designed as club systems for entertainment, to reach the best near field quality, vocal coherence, and a stable sound pressure level even at high volumes. It features a 12" woofer and a 1" compression driver. The passive C MAX Series speakers represent a further step of the famous COMPACT Series. Thanks to the bass reflex port, perfectly tuned on the back of the cabinet, the system gives its best when installed near walls, without the need of a subwoofer. It's perfect for KTV, Karaoke rooms, conference halls, AV installations, public areas and clubs.

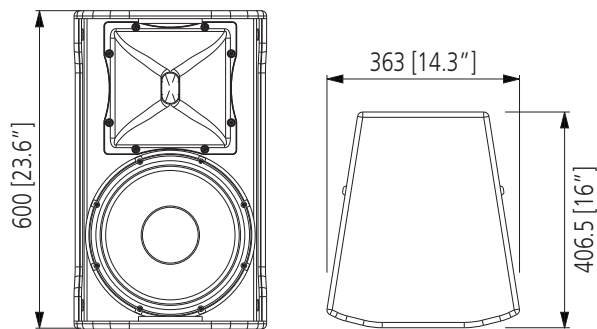

/ FRONT GRILLE

A strong powder-coated metal grille protects the front, and a transparent to sound foam backing on the inside of the grille ensures protection from dust and humidity.

/ AVOID VIBRATIONS

Small isolating rubber elements placed between the cabinet's edges and the grille avoid unwanted vibration.



/ LOW FREQUENCY TRANSDUCER

The high power 12" woofer is designed to provide an excellent frequency response linearity with very low distortion. A strong magnetic structure guarantee dynamic and precision.

/ HI FREQUENCY TRANSDUCERS

The RCF ND340 is an extremely compact 1.75" compression driver with 1.0" voice coil for professional applications. Flexible and easy to crossover, it offers high efficiency combined with a very high frequency extension.



FLYING POINTS

Thirteen M10 flying points – 9 on the corners and 4 on the sides.



/ BA EX

Rear bass reflex allows a broader extension of low frequencies when the speakers are close to a wall.

- 400 W AES power rating
- 60 ÷ 20000 Hz Frequency Range
- 90° x 70° Coverage
- 130 dB SPL Max
- Custom designed mid-freq (2-4 kHz) shaping for close distance listening
- Heavy-duty birch plywood coated with black textured epoxy
- Genuine CUSTOM RCF precision Transducer
- Unique minimum phase filter



SPECIFICATIONS

C MAX 4112

p.n. 130.00.535

ACOUSTICAL

FREQ. RANGE (-10 dB):	60 Hz ÷ 20 kHz
HORIZ. COVERAGE ANGLE (-6 dB):	90°
VERTICAL COVERAGE ANGLE (-6 dB):	70°
DIRECTIVITY FACTOR Q:	11
SYSTEM SENSITIVITY:	98 dB, 1W @ 1m ⁽¹⁾
RATED MAXIMUM SPL:	130 dB, @ 1m
SYSTEM NOMINAL IMPEDANCE:	8 ohm
SYSTEM INPUT POWER RATING RMS:	400 W ⁽²⁾
SYSTEM INPUT POWER RATING PEAK:	1600 W
RECOMMENDED AMPLIFIER:	800 W ⁽³⁾
HF PROTECTION:	Bulb Lamp
CROSSOVER:	1.8 kHz

TRANSDUCERS

LOW FREQUENCY:	12" woofer 3" voice coil
NOMINAL IMPEDANCE:	8 ohm
INPUT POWER RATING:	350 W AES; 700 W Peak
SENSITIVITY:	98 dB, 1W @ 1m
HIGH FREQUENCY:	1.0" driver 1.75" voice coil
NOMINAL IMPEDANCE:	16 ohm
INPUT POWER RATING:	60 W AES; 120 W Peak
SENSITIVITY:	106 dB, 1W @ 1m

PHYSICAL

ENCLOSURE:	15 mm Birch Plywood
RIGGING INSERTS:	Pole mount, 12 x M10
COLOR:	Black
GRILLE:	Custom perforated steel grille
INPUT CONNECTORS:	2 x SPEAKON NL4
DIMENSIONS (H x W x D):	23.6" x 14.3" x 16" 600 x 363 x 406.5 mm
WEIGHT:	54 lbs 24.5 kg

RESPONSE 1W/1m

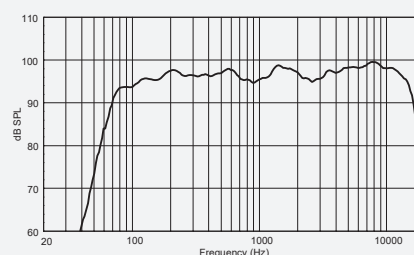

BEAMWIDTH vs. FREQUENCY

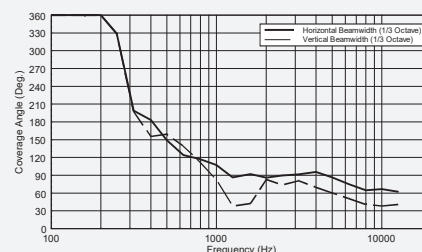

DIRECTIVITY INDEX AND Q

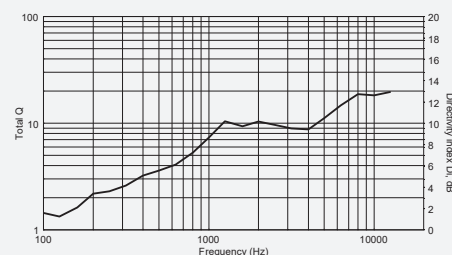

APPLICATIONS

- Music Playback
- Sound Reinforcement
- Conference halls
- AV installations
- Public areas
- Clubs & DJ

1) Measured on axis in the far field with 1 watt (2.83V RMS, 8 ohm) input and referenced to 1 meter distance using the inverse square law. Listed sound pressure represents an average from 300 Hz to 3 kHz.

2) Using 20 Hz to 20 kHz, Pink Noise Spectrum, 2 hours, + 6 dB crest factor, with RMS voltage calculated on speaker minimum impedance.

3) Recommended Amplifier is a power capability value that should be taken as a guide.

4110

C MAX



C MAX 4110

FULL RANGE HIGH POWER NEARFIELD SPEAKER

The full-range passive two-way speaker RCF C MAX 4110 has been specifically designed as club systems for entertainment, to reach the best near field quality, vocal coherence, and a stable sound pressure level even at high volumes. It features a 10" woofer and a 1" compression driver. The passive C MAX Series speakers represent a further step of the famous COMPACT Series. Thanks to the bass reflex port, perfectly tuned on the back of the cabinet, the system gives its best when installed near walls, without the need of a subwoofer. It's perfect for KTV, Karaoke rooms, conference halls, AV installations, public areas and clubs.

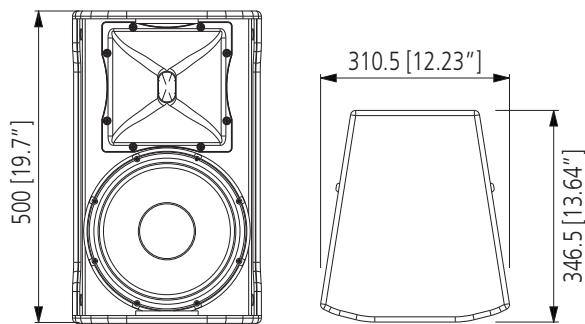

/ FRONT GRILLE

A strong powder-coated metal grille protects the front, and a transparent to sound foam backing on the inside of the grille ensures protection from dust and humidity.

/ LOW FREQUENCY TRANSDUCER

The high power 10" woofer is designed to provide an excellent frequency response linearity with very low distortion. A strong magnetic structure guarantee dynamic and precision.

/ HI FREQUENCY TRANSDUCERS

The RCF ND340 is an extremely compact 1.75" compression driver with 1.0" voice coil for professional applications. Flexible and easy to crossover, it offers high efficiency combined with a very high frequency extension.



FLYING POINTS

Thirteen M10 flying points – 9 on the corners and 4 on the sides.



/ BA EX

Rear bass reflex allows a broader extension of low frequencies when the speakers are close to a wall.

/ AVOID VIBRATIONS

Small isolating rubber elements placed between the cabinet's edges and the grille avoid unwanted vibration.



- 350 W AES power rating
- 65 ÷ 20000 Hz Frequency Range
- 90° x 70° Coverage
- 128 dB SPL Max
- Custom designed mid-freq (2-4 kHz) shaping for close distance listening
- Heavy-duty birch plywood coated with black textured epoxy
- Genuine CUSTOM RCF precision Transducer
- Unique minimum phase filter



SPECIFICATIONS

C MAX 4110

p.n. 130.00.534

ACOUSTICAL

FREQ. RANGE (-10 dB):	65 Hz ÷ 20 kHz
HORIZ. COVERAGE ANGLE (-6 dB):	90°
VERTICAL COVERAGE ANGLE (-6 dB):	70°
DIRECTIVITY FACTOR Q:	11
SYSTEM SENSITIVITY:	97 dB, 1W @ 1m ⁽¹⁾
RATED MAXIMUM SPL:	128 dB, @ 1m
SYSTEM NOMINAL IMPEDANCE:	8 ohm
SYSTEM INPUT POWER RATING RMS:	350 W ⁽²⁾
SYSTEM INPUT POWER RATING PEAK:	1400 W
RECOMMENDED AMPLIFIER:	1800 W ⁽³⁾
HF PROTECTION:	Bulb Lamp
CROSSOVER:	1.8 kHz

TRANSDUCERS

LOW FREQUENCY:	10" woofer 2.5" voice coil
NOMINAL IMPEDANCE:	8 ohm
INPUT POWER RATING:	300 W AES; 600 W Peak
SENSITIVITY:	97 dB, 1W @ 1m
HIGH FREQUENCY:	1.0" driver 1.75" voice coil
NOMINAL IMPEDANCE:	16 ohm
INPUT POWER RATING:	60 W AES; 120 W Peak
SENSITIVITY:	106 dB, 1W @ 1m

PHYSICAL

ENCLOSURE:	15 mm Birch Plywood
RIGGING INSERTS:	Pole mount, 12 x M10
COLOR:	Black
GRILLE:	Custom perforated steel grille
INPUT CONNECTORS:	2 x SPEAKON NL4
DIMENSIONS (H x W x D):	19.69" x 12.17" x 13.78" 500 x 309 x 350 mm
WEIGHT:	34.17 lbs 15.5 kg

RESPONSE 1W/1m

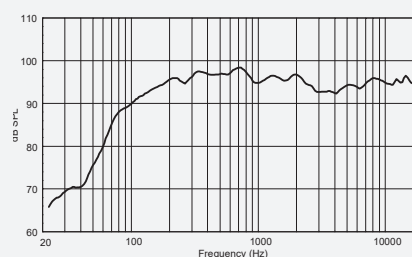

BEAMWIDTH vs. FREQUENCY

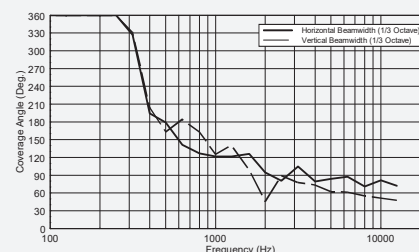

DIRECTIVITY INDEX AND Q

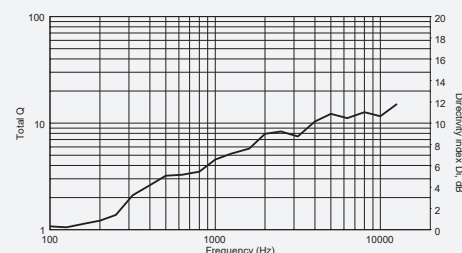

APPLICATIONS

- Music Playback
- Sound Reinforcement
- Conference halls
- AV installations
- Public areas
- Clubs & DJ

1) Measured on axis in the far field with 1 watt (2.83V RMS, 8 ohm) input and referenced to 1 meter distance using the inverse square law. Listed sound pressure represents an average from 300 Hz to 3 kHz.

2) Using 20 Hz to 20 kHz, Pink Noise Spectrum, 2 hours, + 6 dB crest factor, with RMS voltage calculated on speaker minimum impedance.

3) Recommended Amplifier is a power capability value that should be taken as a guide.

3112

E MAX

E MAX 3112

FULL RANGE HIGH POWER NEARFIELD SPEAKER

The full-range passive two-way RCF E MAX series has been specifically designed for clubs entertainment systems, to achieve the best nearfield quality, vocal coherence and a stable tonal balance even at high volume. The heavy-duty cabinet is made of birch plywood coated with black textured epoxy. Featuring a 12" woofer with a 2.5" voice coil and a 1.0" compression driver with 1.4" voice coil. The Low Impedance Compensated Crossover (LICC) crossover design includes an electronic protection on high-frequency device. The rotatable 90°x70° horn and the available mounting accessories allow speaker installation both vertically or horizontally in any environment and architectural constraint.

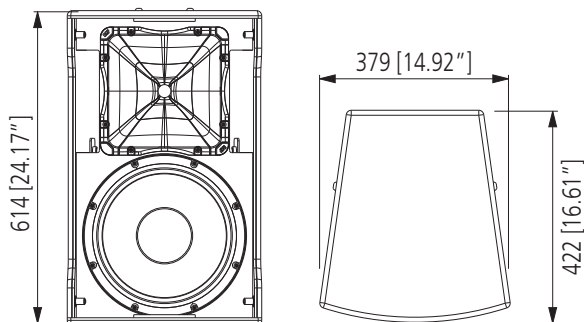

/ LOW FREQUENCY TRANSDUCER

The high power 12" woofer with a 2.5" voice coil is designed to provide excellent frequency response linearity with very low distortion.

/ HI FREQUENCY TRANSDUCERS

The 1.0" compression driver with 1.4" voice coil provides accurate and coherent response even at very high frequencies. The horn is rotatable, allowing speaker installation both vertically or horizontally.

/ PERFECTLY TUNED CROSSOVER

The E MAX Series features a custom designed mid-freq shaping for close distance listening on a perfectly tuned crossover to ensure the best frequency and phase response. The LICC crossover design includes electronic protection on high-frequency device.

/ FRONT GRILLE

A strong powder-coated metal grille protects the front, and a transparent to sound foam applied on the inside of the grille ensures protection from dust and humidity.



BASS REFLEX

- 129 dB SPL Max
- 350 W AES power rating
- 55 ÷ 20000 Hz frequency range
- Plywood coated with black textured acrylic paint
- 1" compression driver, 12" woofer hi resolution transducers
- Perfectly tuned crossover

/ AVOID VIBRATIONS

Small isolating rubber elements placed between the cabinet's edges and the grille avoid unwanted vibration.



SPECIFICATIONS

E MAX 3112

p.n. 130.00.578

ACOUSTICAL

FREQ. RANGE (-10 dB):	55 Hz ÷ 20 kHz
HORIZ. COVERAGE ANGLE (-6 dB):	90°
VERTICAL COVERAGE ANGLE (-6 dB):	70°
DIRECTIVITY FACTOR Q:	11
SYSTEM SENSITIVITY:	98 dB, 1W @ 1m ⁽¹⁾
RATED MAXIMUM SPL:	129 dB, @ 1m
SYSTEM NOMINAL IMPEDANCE:	8 ohm
SYSTEM INPUT POWER RATING RMS:	350 W ⁽²⁾
SYSTEM INPUT POWER RATING PEAK:	1400 W
RECOMMENDED AMPLIFIER:	700 W ⁽³⁾
HF PROTECTION:	Active Mosfet
CROSSOVER:	1.8 kHz

TRANSDUCERS

LOW FREQUENCY:	12" woofer 2.5" voice coil
NOMINAL IMPEDANCE:	8 ohm
INPUT POWER RATING:	300 W AES; 600 W Peak
SENSITIVITY:	98 dB, 1W @ 1m
HIGH FREQUENCY:	1.0" driver 1.5" voice coil
NOMINAL IMPEDANCE:	8 ohm
INPUT POWER RATING:	50 W AES; 100 W Peak
SENSITIVITY:	106 dB, 1W @ 1m

PHYSICAL

ENCLOSURE:	15 mm Birch Plywood
RIGGING INSERTS:	Pole mount, 17 x M10, 2 x M8
COLOR:	Black
GRILLE:	Custom perforated steel grille
INPUT AND OUTPUT CONNECTORS:	SPEAKON NL4
DIMENSIONS (H x W x D):	24.17" x 15" x 16.61" 614 x 381 x 422 mm
WEIGHT:	48.50 lbs 22 kg

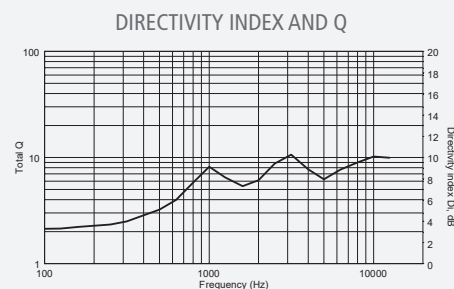
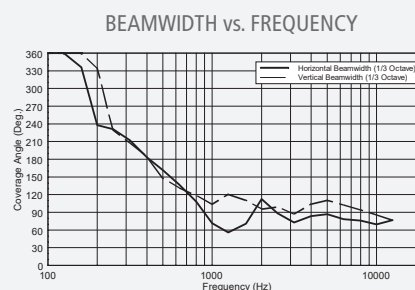
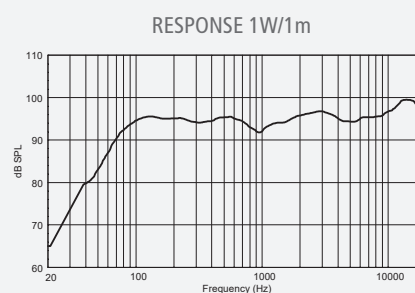

APPLICATIONS

- Music Playback
- Sound Reinforcement
- Conference halls
- AV installations
- Public areas
- Clubs & DJ

1) Measured on axis in the far field with 1 watt (2.83V RMS, 8 ohm) input and referenced to 1 meter distance using the inverse square law. Listed sound pressure represents an average from 300 Hz to 3 kHz.

2) Using 20 Hz to 20 kHz, Pink Noise Spectrum, 2 hours, + 6 dB crest factor, with RMS voltage calculated on speaker minimum impedance.

3) Recommended Amplifier is a power capability value that should be taken as a guide.

3110

E MAX

E MAX 3110

FULL RANGE HIGH POWER NEARFIELD SPEAKER

The full-range passive two-way RCF E-MAX series has been specifically designed for clubs entertainment systems, to achieve the best nearfield quality, vocal coherence and a stable tonal balance even at high volume. The heavy-duty cabinet is made of birch plywood coated with black textured epoxy. Featuring a 10" woofer with a 2.5" voice coil and a 1.0" compression driver with 1.4" voice coil. The Low Impedance Compensated Crossover (LICC) crossover design includes an electronic protection on high-frequency device. The rotatable 90°x70° horn and the available mounting accessories allow speaker installation both vertically or horizontally, in any environment and architectural constraint.

/ LOW FREQUENCY TRANSDUCER

The high power 10" woofer with a 2.5" voice coil is designed to provide excellent frequency response linearity with very low distortion.

/ HI FREQUENCY TRANSDUCERS

The 1.0" compression driver with 1.4" voice coil provides accurate and coherent response even at very high frequencies. The horn is rotatable, allowing speaker installation both vertically or horizontally.

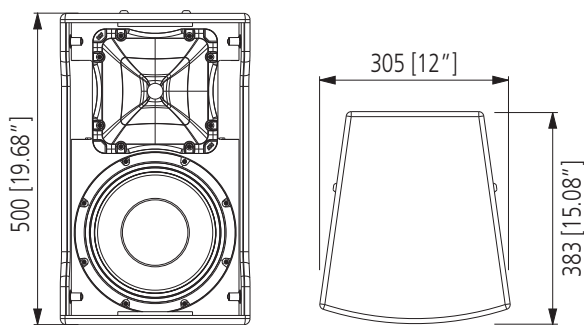

/ FRONT GRILLE

A strong powder-coated metal grille protects the front, and a transparent to sound foam applied on the inside of the grille ensures protection from dust and humidity.



BASS REFLEX

/ AVOID VIBRATIONS

Small isolating rubber elements placed between the cabinet's edges and the grille avoid unwanted vibration.

- 128 dB SPL Max
- 300 W AES power rating
- 60 ÷ 20000 Hz frequency range
- Plywood coated with black textured acrylic paint
- 1" Compression driver, 10" woofer hi resolution transducers
- Perfectly tuned crossover



SPECIFICATIONS

E MAX 3110

p.n. 130.00.577

ACOUSTICAL

FREQ. RANGE (-10 dB):	60 Hz ÷ 20 kHz
HORIZ. COVERAGE ANGLE (-6 dB):	90°
VERTICAL COVERAGE ANGLE (-6 dB):	70°
DIRECTIVITY FACTOR Q:	11
SYSTEM SENSITIVITY:	98 dB, 1W @ 1m ⁽¹⁾
RATED MAXIMUM SPL:	128 dB, @ 1m
SYSTEM NOMINAL IMPEDANCE:	8 ohm
SYSTEM INPUT POWER RATING RMS:	300 W ⁽²⁾
SYSTEM INPUT POWER RATING PEAK:	1200 W
RECOMMENDED AMPLIFIER:	600 W ⁽³⁾
HF PROTECTION:	Active Mosfet
CROSSOVER:	1.8 kHz

TRANSDUCERS

LOW FREQUENCY:	10" woofer 2.5" voice coil
NOMINAL IMPEDANCE:	8 ohm
INPUT POWER RATING:	300 W AES; 600 W Peak
SENSITIVITY:	98 dB, 1W @ 1m
HIGH FREQUENCY:	1.0" driver 1.5" voice coil
NOMINAL IMPEDANCE:	8 ohm
INPUT POWER RATING:	50 W AES; 100 W Peak
SENSITIVITY:	106 dB, 1W @ 1m

PHYSICAL

ENCLOSURE:	15 mm Birch Plywood
RIGGING INSERTS:	Pole mount, 17 x M10, 2 x M8
COLOR:	Black
GRILLE:	Custom perforated steel grille
INPUT AND OUTPUT CONNECTORS:	SPEAKON NL4
DIMENSIONS (H x W x D):	19.69" x 12.01" x 13.31" 500 x 305 x 338 mm
WEIGHT:	35.63 lbs 16.16 kg

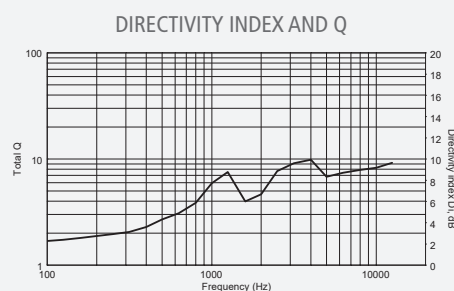
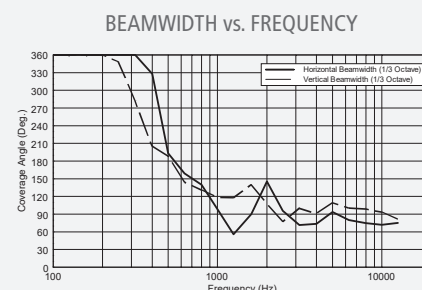
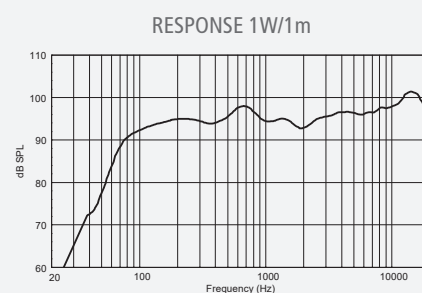

APPLICATIONS

- Music Playback
- Sound Reinforcement
- Conference halls
- AV installations
- Public areas
- Clubs & DJ

¹⁾ Measured on axis in the far field with 1 watt (2.83V RMS, 8 ohm) input and referenced to 1 meter distance using the inverse square law. Listed sound pressure represents an average from 300 Hz to 3 kHz.

²⁾ Using 20 Hz to 20 kHz, Pink Noise Spectrum, 2 hours, + 6 dB crest factor, with RMS voltage calculated on speaker minimum impedance.

³⁾ Recommended Amplifier is a power capability value that should be taken as a guide.

5215

COMPACT SERIES

C 5215-99 | C 5215-96 | C 5215-94 | C 5215-66 | C 5215-64

TWO-WAY PASSIVE SPEAKER

C 5215s are full range extremely versatile wide-dispersion, two-way loudspeaker system offering substantial power and efficiency for several professional applications that include main sound systems for permanent installations, plus portable systems and supplementary fill for larger systems.

RCF exclusive 'Constant Matching Design' technology helps guarantee an optimal transition between the high frequency horn polar pattern and the low frequency woofer directivity. The horn can be rotated, allowing to install the loudspeaker either vertically or horizontally.

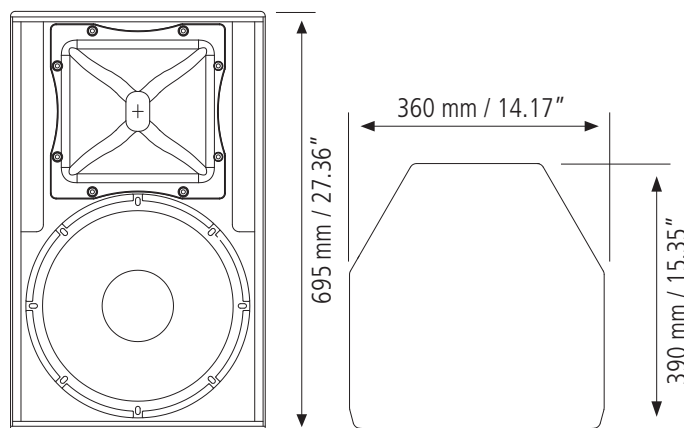

RELATED ACCESSORIES



FL-BR NC 12-15 p.n. 133.60.201

Flying bracket. Adjustable inclination.



H-BR 2X NC15 p.n. 133.60.193

Pair of horizontal brackets. Adjustable inclination.

SUGGESTED PROCESSOR



DX 4008 p.n. 121.35.033

4 inputs, 8 output digital processor

The system includes a high-level crossover network that features markedly lower (than conventional) induction values in series with the woofer. This innovation is named LICC ('Low Impedance Compensated Crossover': its benefits are delay reduction, reduced phase shift and superior transient response.

Dynamic high-frequency driver protection is accomplished with a new RCF exclusive - 'Active Mosfet Compression Driver Protection System' (AMCDP), chosen to complement the driver power curve.

- CMD (Constant Matching Design) constant directivity horn
- 1.4" compression driver with 2.5" diaphragm assembly
- 15" woofer with 3" voice coil
- Dual-function design: built in passive crossover or external bi-amp
- Rotatable Horn System for horizontal cabinet mounting applications
- HF driver AMCDP (Active Mosfet Compression Driver Protection)
- LICC (Low Impedance Compensated Crossover) network
- 14 Suspension points
- Pole mount joint



SPECIFICATIONS

C 5215-99	C 5215-96	C 5215-94	C 5215-66	C 5215-64
p.n.130.00.313	p.n.130.00.311	p.n.130.00.309	p.n.130.00.312	p.n.130.00.310

ACOUSTICAL

FREQ. RANGE (-10 dB):	48 Hz ÷ 20 kHz	48 Hz ÷ 20 kHz	48 Hz ÷ 20 kHz	48 Hz ÷ 20 kHz	48 Hz ÷ 20 kHz
HORIZ. COVERAGE ANGLE (-6 dB):	90°	90°	90°	60°	60°
VERTICAL COVERAGE ANGLE (-6 dB):	90°	60°	40°	60°	40°
DIRECTIVITY FACTOR Q:	11	12	14	20	20
SYSTEM SENSITIVITY:	100 dB	100 dB	100 dB	101 dB	101 dB
RATED MAXIMUM SPL:	133 dB	133 dB	133 dB	134 dB	134 dB
SYSTEM NOMINAL IMPEDANCE:	8 ohm	8 ohm	8 ohm	8 ohm	8 ohm
SYSTEM INPUT POWER RATING RMS:	500 W ⁽²⁾	500 W ⁽²⁾	500 W ⁽²⁾	500 W ⁽²⁾	500 W ⁽²⁾
SYSTEM INPUT POWER RATING PEAK:	2000 W	2000 W	2000 W	2000 W	2000 W
RECOMMENDED AMPLIFIER:	1000 W ⁽³⁾	1000 W ⁽³⁾	1000 W ⁽³⁾	1000 W ⁽³⁾	1000 W ⁽³⁾
HF PROTECTION	Dynamic	Dynamic	Dynamic	Dynamic	Dynamic
CROSSOVER:	1,2 kHz	1,2 kHz	1,2 kHz	1,2 kHz	1,2 kHz

TRANSDUCERS

LOW FREQUENCY:	15" (381 mm) woofer 3" (76 mm) voice coil
NOMINAL IMPEDANCE:	8 ohm
INPUT POWER RATING:	400 W AES 800 W Peak
SENSITIVITY:	99 dB, 1W @ 1m
HIGH FREQUENCY:	1.4" (36 mm) driver 2.5" (64 mm) voice coil
NOMINAL IMPEDANCE:	8 ohm
INPUT POWER RATING:	100 W AES 200 W Peak
SENSITIVITY:	111 dB, 1W @ 1m

PHYSICAL

ENCLOSURE:	15 mm birch plywood construction
RIGGING INSERTS:	14 x M10
COLOR:	Black
GRILLE:	Custom perforated steel grille, epoxy powder coated, covered with polyurethane
INPUT CONNECTORS:	Speakon® NL4
DIMENSIONS (H x W x D):	27.36" x 16.93" x 18.11" 695 x 430 x 460 mm
WEIGHT:	76.72 lbs 34.8 kg

1) Measured on axis in the far field with 1 watt (2.83V RMS, 8 ohm) input and referenced to 1 meter distance using the inverse square law. Listed sound pressure represents an average from 300 Hz to 3 kHz.

2) Using 20 Hz to 20 kHz, Pink Noise Spectrum, 2 hours, + 6 dB crest factor, with RMS voltage calculated on speaker minimum impedance.

3) Recommended Amplifier is a power capability value that should be taken as a guide.

5215

COMPACT SERIES

C 5215-99 | C 5215-96 | C 5215-94 | C 5215-66 | C 5215-64

TWO-WAY PASSIVE SPEAKER



/ HIGH FREQUENCY

The hi-frequency transducer is a 1.4" RCF PRECISION compression driver with a 2.5" voice coil for smooth, wide dispersion.



/ LOW FREQUENCY

The low-frequency transducer is an 15" RCF PRECISION woofer with a 3" voice coil.

/ CABINET

The cabinet is made of Baltic birch (heavy duty painted) and allow different installation options, as it is equipped with top and bottom 'Multiplates' for either wall or suspended mounting with chains.

Installation points are available on its rear panel as well.

The steel front grille is protected with a double layer polyurethane fabric. The front RCF logo is easily rotatable.



/ CONNECTORS

Connections are made through two Neutrik Speakon NL4 connectors (audio input and parallel link output).

APPLICATIONS

- Permanent Installations
- Main reinforcement in small and medium spaces
- High-level AV playback
- Cluster configurations
- Live music reinforcement

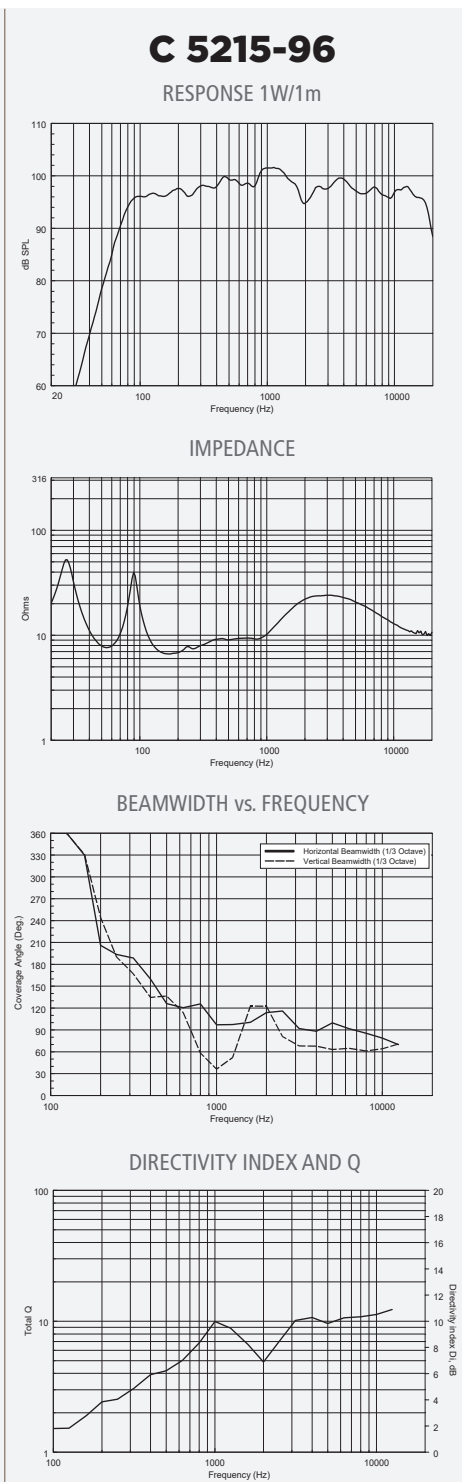
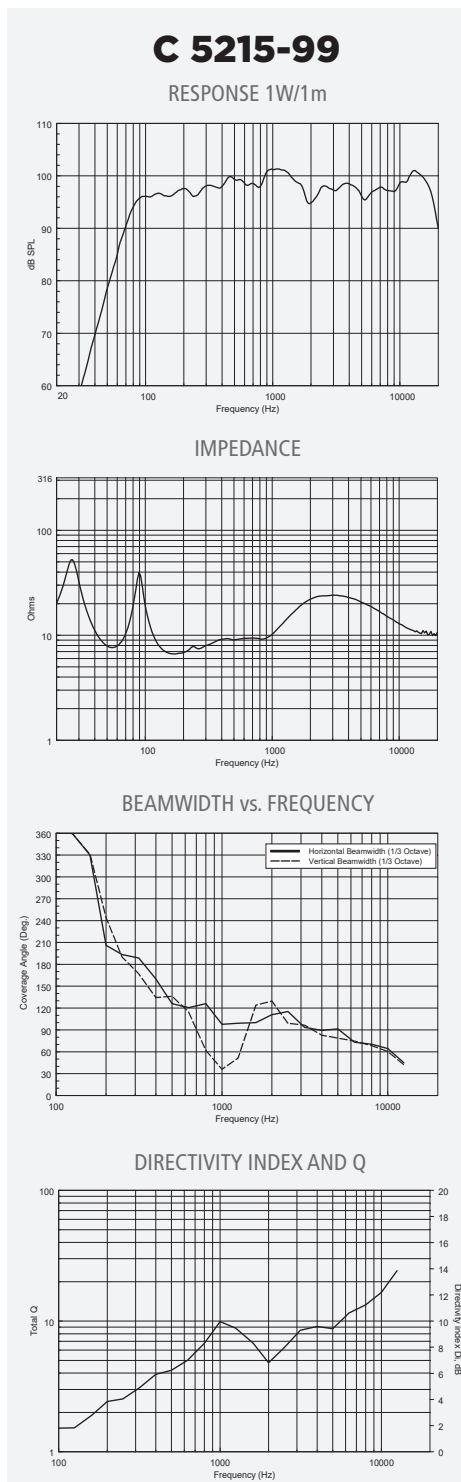



C 5215-94

RESPONSE 1W/1m

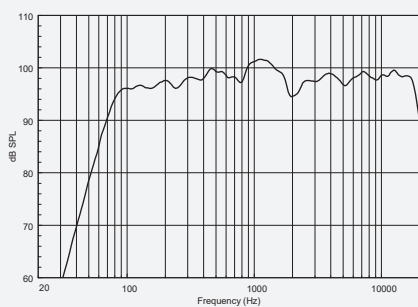

IMPEDANCE

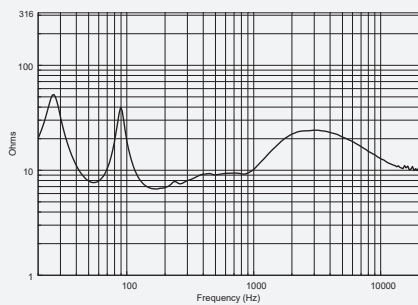

BEAMWIDTH vs. FREQUENCY

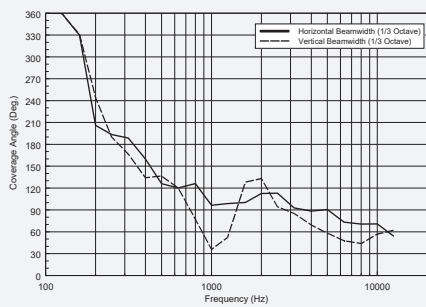

DIRECTIVITY INDEX AND Q

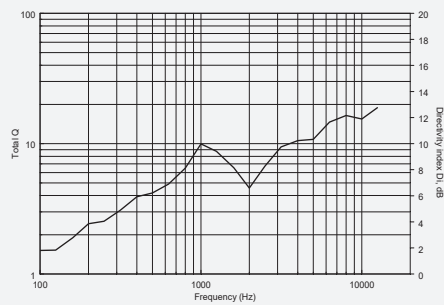

C 5215-66

RESPONSE 1W/1m

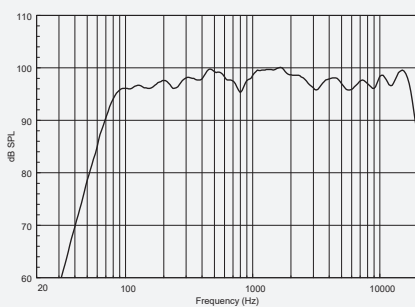

IMPEDANCE

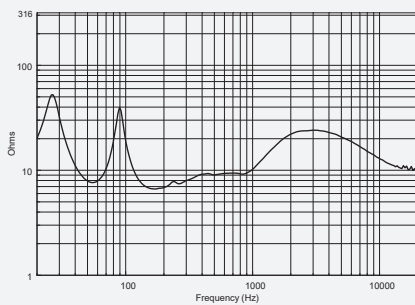

BEAMWIDTH vs. FREQUENCY

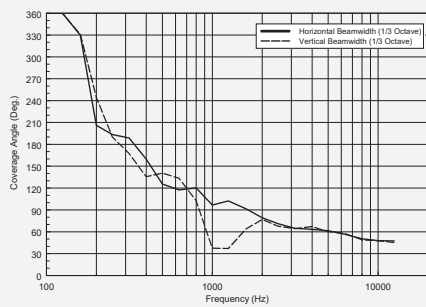

DIRECTIVITY INDEX AND Q

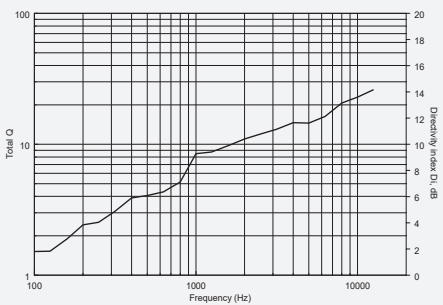

C 5215-64

RESPONSE 1W/1m

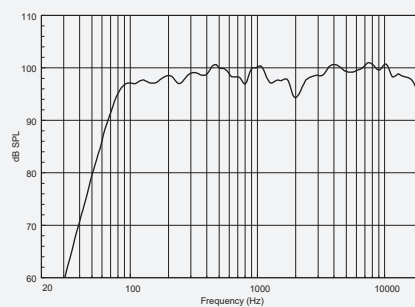

IMPEDANCE

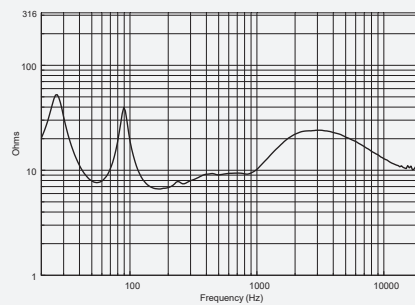

BEAMWIDTH vs. FREQUENCY

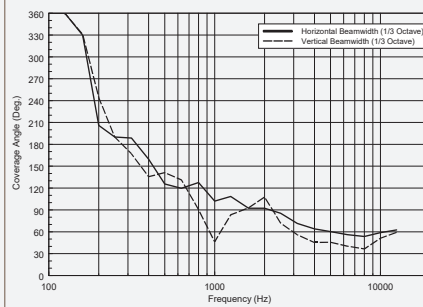

DIRECTIVITY INDEX AND Q

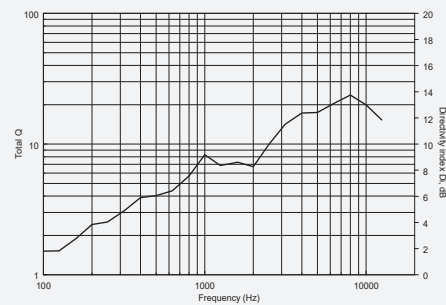

5212

COMPACT SERIES

C 5212-99 | C 5212-96 | C 5212-94 | C 5212-66 | C 5212-64

TWO-WAY PASSIVE SPEAKER

C 5212s are full range extremely versatile wide-dispersion, two-way loudspeaker system offering substantial power and efficiency for several professional applications that include main sound systems for permanent installations, plus portable systems and supplementary fill for larger systems.

RCF exclusive 'Constant Matching Design' technology helps guarantee an optimal transition between the high frequency horn polar pattern and the low frequency woofer directivity. The horn can be rotated, allowing to install the loudspeaker either vertically or horizontally.

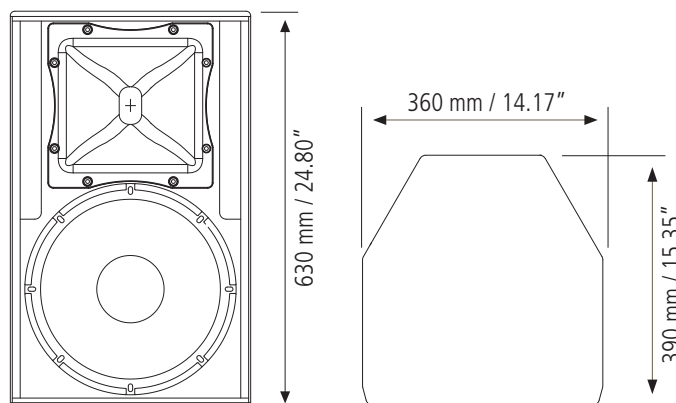

- CMD (Constant Matching Design) constant directivity horn
- 1.4" compression driver with 2.5" diaphragm assembly
- 12" woofer with 3" voice coil
- Rotatable Horn System for horizontal cabinet mounting applications
- HF driver AMCDP (Active Mosfet Compression Driver Protection)
- LICC (Low Impedance Compensated Crossover) network
- 10 Suspension points
- 1 top pole mount, 1 bottom pole mount

RELATED ACCESSORIES

	FL-BR NC 12-15	p.n. 133.60.201
Flying bracket. Adjustable inclination.		
	H-BR 2X NC12	p.n. 133.60.192
Pair of horizontal brackets.		
	V-BR 2X NC12	p.n. 133.60.197
Pair of vertical brackets.		

The system includes a high-level crossover network that features markedly lower (than conventional) induction values in series with the woofer. This innovation is named LICC ('Low Impedance Compensated Crossover': its benefits are delay reduction, reduced phase shift and superior transient response.

Dynamic high-frequency driver protection is accomplished with a new RCF exclusive - 'Active Mosfet Compression Driver Protection System' (AMCDP), chosen to complement the driver power curve.





SPECIFICATIONS

C 5212-99	C 5212-96	C 5212-94	C 5212-66	C 5212-64
p.n.130.00.308	p.n.130.00.306	p.n.130.00.304	p.n.130.00.307	p.n.130.00.305

ACOUSTICAL

FREQ. RANGE (-10 dB):	54 Hz ÷ 20 kHz	54 Hz ÷ 20 kHz	54 Hz ÷ 20 kHz	54 Hz ÷ 20 kHz	54 Hz ÷ 20 kHz
HORIZ. COVERAGE ANGLE (-6 dB):	90°	90°	90°	60°	60°
VERTICAL COVERAGE ANGLE (-6 dB):	90°	60°	40°	60°	40°
DIRECTIVITY FACTOR Q:	13	13	13	16	16
SYSTEM SENSITIVITY:	99 dB	99 dB	99 dB	100 dB	100 dB
RATED MAXIMUM SPL:	132 dB	132 dB	132 dB	133 dB	133 dB
SYSTEM NOMINAL IMPEDANCE:	8 ohm	8 ohm	8 ohm	8 ohm	8 ohm
SYSTEM INPUT POWER RATING RMS:	500 W ⁽²⁾	500 W ⁽²⁾	500 W ⁽²⁾	500 W ⁽²⁾	500 W ⁽²⁾
SYSTEM INPUT POWER RATING PEAK:	2000 W	2000 W	2000 W	2000 W	2000 W
RECOMMENDED AMPLIFIER:	1000 W ⁽³⁾	1000 W ⁽³⁾	1000 W ⁽³⁾	1000 W ⁽³⁾	1000 W ⁽³⁾
HF PROTECTION	Dynamic	Dynamic	Dynamic	Dynamic	Dynamic
CROSSOVER:	1,2 kHz	1,2 kHz	1,2 kHz	1,2 kHz	1,2 kHz

TRANSDUCERS

LOW FREQUENCY:	12" (304 mm) woofer 3" (76 mm) voice coil
NOMINAL IMPEDANCE:	8 ohm
INPUT POWER RATING:	400 W AES 800 W Peak
SENSITIVITY:	98 dB, 1W @ 1m
HIGH FREQUENCY:	1.4" (36 mm) driver 2.5" (64 mm) voice coil
NOMINAL IMPEDANCE:	8 ohm
INPUT POWER RATING:	100 W AES 200 W Peak
SENSITIVITY:	111 dB, 1W @ 1m

PHYSICAL

ENCLOSURE:	15 mm birch plywood construction
RIGGING INSERTS:	14 x M10
COLOR:	Black
GRILLE:	Custom perforated steel grille, epoxy powder coated, covered with polyurethane
INPUT CONNECTORS:	Speakon® NL4
DIMENSIONS (H x W x D):	24.8" x 14.17" x 15.35" 630 x 360 x 390 mm
WEIGHT:	63.93 lbs 29 kg

1) Measured on axis in the far field with 1 watt (2.83V RMS, 8 ohm) input and referenced to 1 meter distance using the inverse square law. Listed sound pressure represents an average from 300 Hz to 3 kHz.

2) Using 20 Hz to 20 kHz, Pink Noise Spectrum, 2 hours, + 6 dB crest factor, with RMS voltage calculated on speaker minimum impedance.

3) Recommended Amplifier is a power capability value that should be taken as a guide.

521

COMPACT SERIES

C 5212-99 | C 5212-96 | C 5212-94 | C 5212-66 | C 5212-64

TWO-WAY PASSIVE SPEAKER



/ HIGH FREQUENCY

The hi-frequency transducer is a 1.4" RCF PRECISION compression driver with a 2.5" voice coil for smooth, wide dispersion.



/ LOW FREQUENCY

The low-frequency transducer is an 12" RCF PRECISION woofer with a 3" voice coil.

/ CABINET

The cabinet is made of Baltic birch (heavy duty painted) and allow different installation options, as it is equipped with top and bottom 'Multiplates' for either wall or suspended mounting with chains.

Installation points are available on its rear panel as well.

The steel front grille is protected with a double layer polyurethane fabric. The front RCF logo is easily rotatable.



/ CONNECTORS

Connections are made through two Neutrik Speakon NL4 connectors (audio input and parallel link output).

APPLICATIONS

- Permanent Installations
- Main reinforcement in small and medium spaces
- High-level AV playback
- Live music reinforcement
- Large speech systems

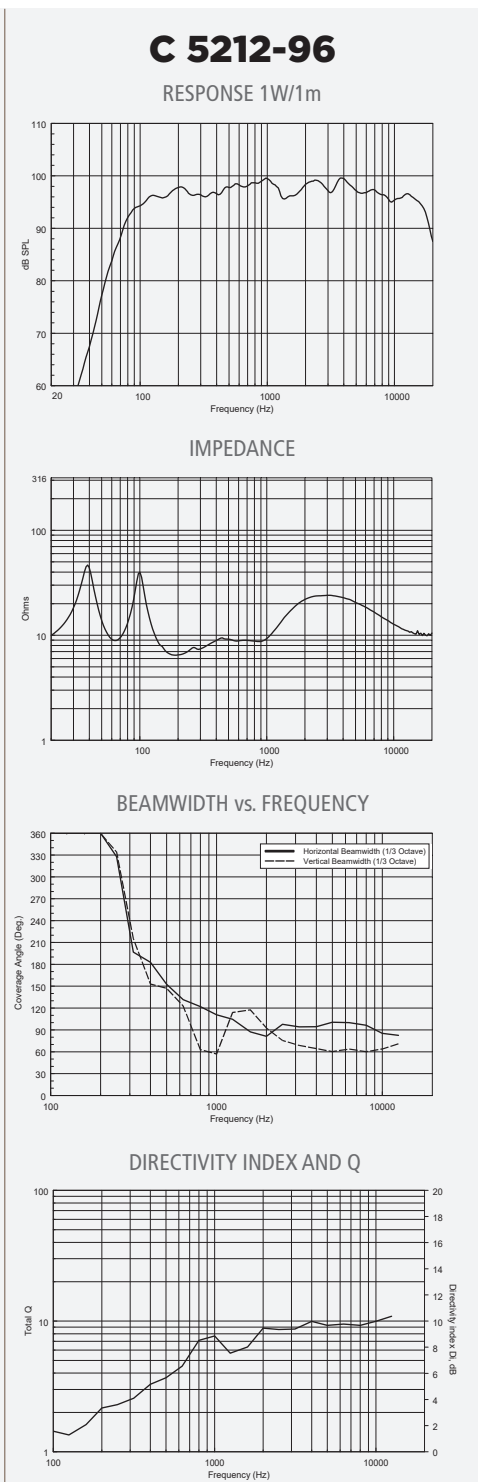
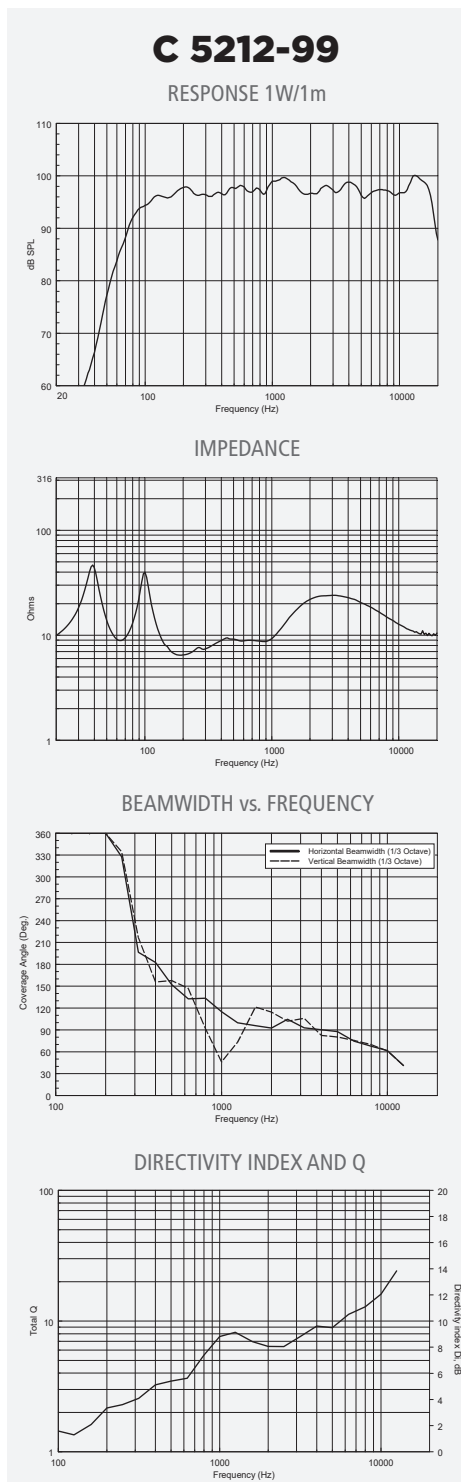



C 5212-94

RESPONSE 1W/1m

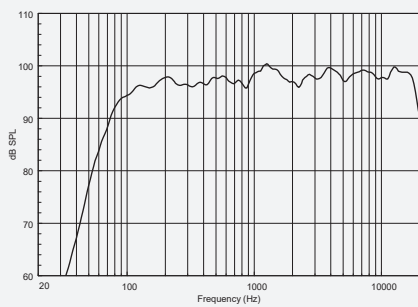

IMPEDANCE

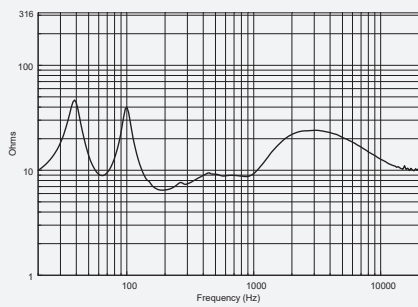

BEAMWIDTH vs. FREQUENCY

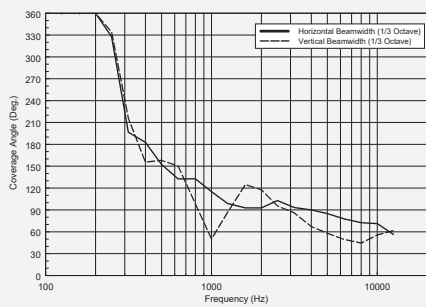

DIRECTIVITY INDEX AND Q

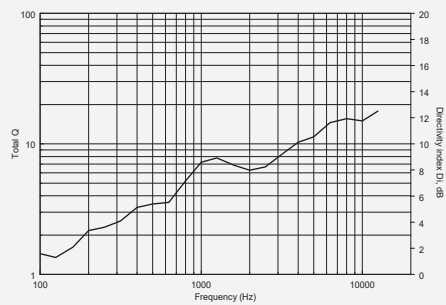

C 5212-66

RESPONSE 1W/1m

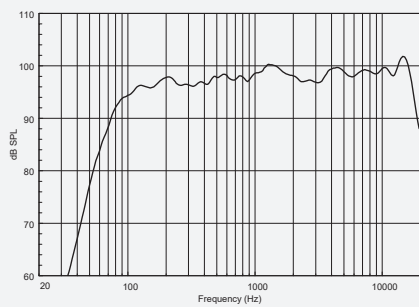

IMPEDANCE

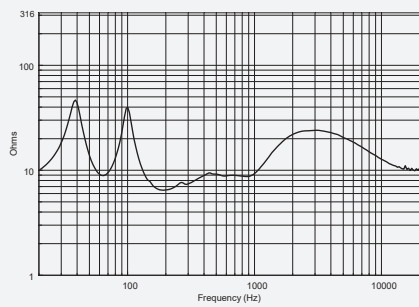

BEAMWIDTH vs. FREQUENCY

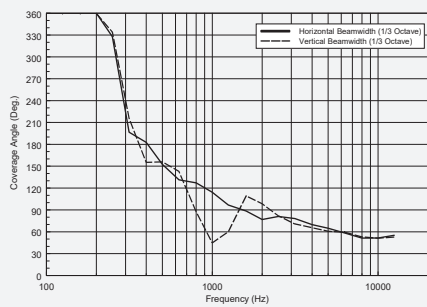

DIRECTIVITY INDEX AND Q

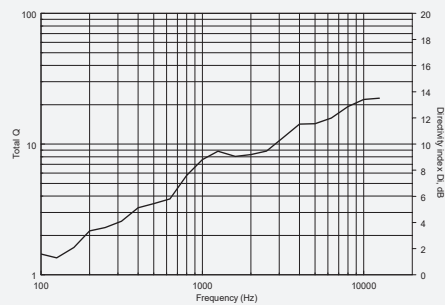

C 5212-64

RESPONSE 1W/1m

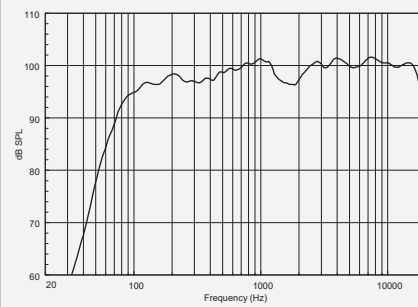

IMPEDANCE

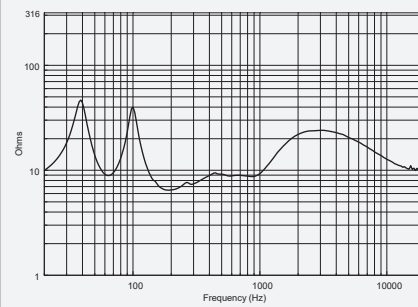

BEAMWIDTH vs. FREQUENCY

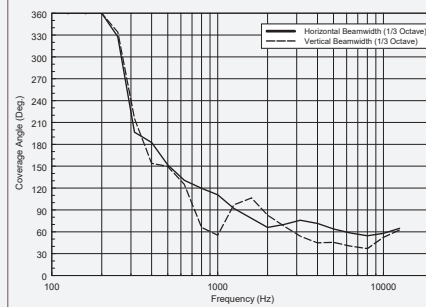

DIRECTIVITY INDEX AND Q

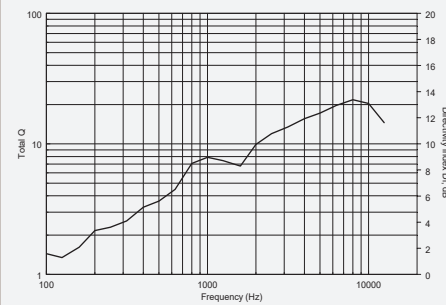

3110

COMPACT SERIES

C 3110-126 | C 3110-96

TWO-WAY PASSIVE SPEAKER

The system includes a high-level crossover network that features markedly lower (than conventional) induction values in series with the woofer. This innovation is named LICC ('Low Impedance Compensated Crossover': its benefits are delay reduction, reduced phase shift and superior transient response.

Dynamic high-frequency driver protection is accomplished with a new RCF exclusive - 'Active Mosfet Compression Driver Protection System' (AMCDP), chosen to complement the driver power curve.



/ CONNECTORS

Connections are made through two Neutrik Speakon NL4 connectors (audio input and parallel link output).

RELATED ACCESSORIES



CL-BR NC

p.n. 133.60.217

Pipe clamp accessory. Adjustable inclination.



FL-BR NC 06-08-10

p.n. 133.60.200

Flying bracket. Adjustable inclination



H-BR 2X NC10

p.n. 133.60.191

Pair of horizontal brackets. Adjustable inclination.



V-BR 2X NC10

p.n. 133.60.196

Pair of vertical brackets. Adjustable inclination.



SWM-BR NC

p.n. 133.60.199

Wall mount swivel bracket.



/ CABINET

The cabinet is made of Baltic birch (heavy duty painted) and allow different installation options, as it is equipped with top and bottom 'Multiplates' for either wall or suspended mounting with chains.

Installation points are available on its rear panel as well.

The steel front grille is protected with a double layer polyurethane fabric.

The front RCF logo is easily rotatable.

APPLICATIONS

- Permanent Installations
- Main Reinforcement in small spaces
- Portable Systems AV Presentations
- Zone Delay and Fill Systems
- Under Balcony Applications



SPECIFICATIONS

C 3110-126

p.n.130.00.284

ACOUSTICAL

FREQ. RANGE (-10 dB):	67 Hz ÷ 20 kHz
HORIZ. COVERAGE ANGLE (-6 dB):	120°
VERTICAL COVERAGE ANGLE (-6 dB):	60°
DIRECTIVITY FACTOR Q:	9
SYSTEM SENSITIVITY:	96.5 dB
RATED MAXIMUM SPL:	127.5 dB
SYSTEM NOMINAL IMPEDANCE:	8 ohm
SYSTEM INPUT POWER RATING RMS:	300 W ⁽²⁾
SYSTEM INPUT POWER RATING PEAK:	1200 W
RECOMMENDED AMPLIFIER:	600 W ⁽³⁾
HF PROTECTION:	Dynamic
CROSSOVER:	2.2 kHz

TRANSDUCERS

LOW FREQUENCY:	10" (254 mm) woofer with 2" (50 mm) coil
NOMINAL IMPEDANCE:	8 ohm
INPUT POWER RATING:	250 W AES; 500 W Peak
SENSITIVITY:	96 dB, 1W @ 1m
HIGH FREQUENCY:	1" (25mm) throat, 1.5" (35,5mm) coil diaphragm assembly
NOMINAL IMPEDANCE:	8 ohm
INPUT POWER RATING:	25 W AES; 50 W Peak
SENSITIVITY:	106 dB, 1W @ 1m

PHYSICAL

ENCLOSURE:	15 mm birch plywood construction
RIGGING INSERTS:	8 x M8 (rear), 2 x M10 (side)
COLOR:	Black
GRILLE:	Custom perforated steel grille, epoxy powder coated, covered with polyurethane perforated cloth
INPUT CONNECTORS:	Speakon® NL4
DIMENSIONS (H x W x D):	19.68" x 11.81" x 11.73" 500 x 300 x 298 mm
WEIGHT:	34.83 lbs 15.8 kg

RESPONSE 1W/1m

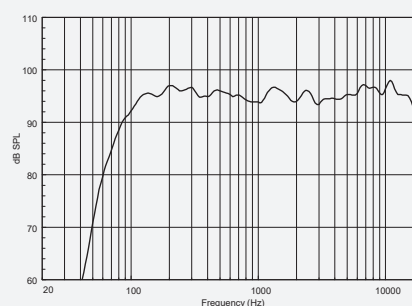

IMPEDANCE

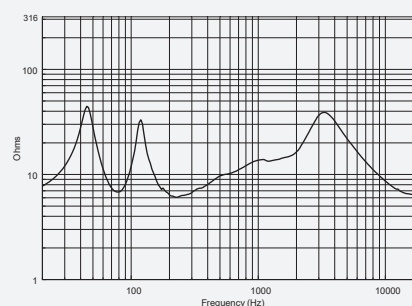

BEAMWIDTH vs. FREQUENCY

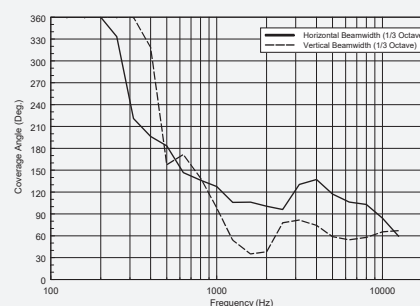

DIRECTIVITY INDEX AND Q

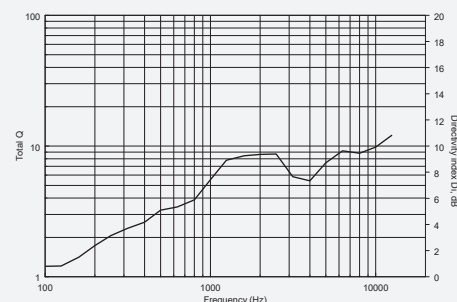

1) Measured on axis in the far field with 1 watt (2.83V RMS, 8 ohm) input and referenced to 1 meter distance using the inverse square law. Listed sound pressure represents an average from 300 Hz to 3 kHz.

2) Using 20 Hz to 20 kHz, Pink Noise Spectrum, 2 hours, + 6 dB crest factor, with RMS voltage calculated on speaker minimum impedance.

3) Recommended Amplifier is a power capability value that should be taken as a guide.

3110

COMPACT SERIES

C 3110-126 | C 3110-96

TWO-WAY PASSIVE SPEAKER

C 3110s are full range extremely versatile wide-dispersion, low profile, two-way loudspeaker systems for near field applications. Their compact size makes them ideal for low visibility side wall mounting. The high-frequency section is a constant directivity horn loaded to a 1" compression driver with a 1.5" diaphragm assembly for smooth, wide dispersion. The low-frequency transducer is a 10" woofer with a 2" voice coil.

RCF exclusive 'Constant Matching Design' technology helps guarantee an optimal transition between the high frequency horn polar pattern and the low frequency woofer directivity. The horn can be rotated, allowing to install the loudspeaker either vertically or horizontally.

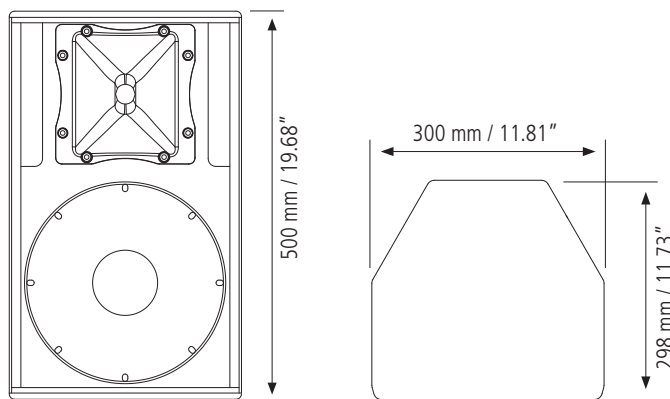

/ HIGH FREQUENCY

The hi-frequency transducer is a 1" RCF PRECISION compression driver with a 1.5" voice coil for smooth, wide dispersion.



/ LOW FREQUENCY

The low-frequency transducer is an 10" RCF PRECISION woofer with a 2" voice coil.

- CMD (Constant Matching Design) constant directivity horn
- 1" compression driver with 1.5" diaphragm assembly
- 10" woofer with 2" voice coil
- Rotatable Horn System for horizontal cabinet mounting applications
- HF driver AMCDP (Active Mosfet Compression Driver Protection)
- LICC (Low Impedance Compensated Crossover) network
- 10 Suspension points
- 1 top pole mount, 1 bottom pole mount





SPECIFICATIONS

C 3110-96

p.n.130.00.283

ACOUSTICAL

FREQ. RANGE (-10 dB):	67 Hz ÷ 20 kHz
HORIZ. COVERAGE ANGLE (-6 dB):	90°
VERTICAL COVERAGE ANGLE (-6 dB):	60°
DIRECTIVITY FACTOR Q:	11
SYSTEM SENSITIVITY:	97 dB
RATED MAXIMUM SPL:	128 dB
SYSTEM NOMINAL IMPEDANCE:	8 ohm
SYSTEM INPUT POWER RATING RMS:	300 W ⁽²⁾
SYSTEM INPUT POWER RATING PEAK:	1200 W
RECOMMENDED AMPLIFIER:	600 W ⁽³⁾
HF PROTECTION:	Dynamic
CROSSOVER:	2.2 kHz

TRANSDUCERS

LOW FREQUENCY:	10" (254 mm) woofer with 2" (50 mm) coil
NOMINAL IMPEDANCE:	8 ohm
INPUT POWER RATING:	250 W AES; 500 W Peak
SENSITIVITY:	96 dB, 1W @ 1m
HIGH FREQUENCY:	1" (25mm) throat, 1.5" (35,5mm) coil diaphragm assembly
NOMINAL IMPEDANCE:	8 ohm
INPUT POWER RATING:	25 W AES; 50 W Peak
SENSITIVITY:	106 dB, 1W @ 1m

PHYSICAL

ENCLOSURE:	15 mm birch plywood construction
RIGGING INSERTS:	8 x M8 (rear), 2 x M10 (side)
COLOR:	Black
GRILLE:	Custom perforated steel grille, epoxy powder coated, covered with polyurethane perforated cloth
INPUT CONNECTORS:	Speakon® NL4
DIMENSIONS (H x W x D):	19.68" x 11.81" x 11.73" 500 x 300 x 298 mm
WEIGHT:	34.83 lbs 15.8 kg

RESPONSE 1W/1m

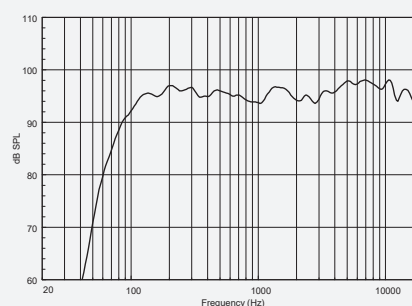

IMPEDANCE

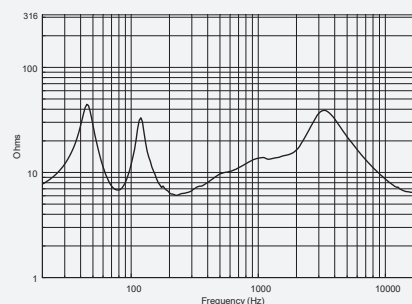

BEAMWIDTH vs. FREQUENCY

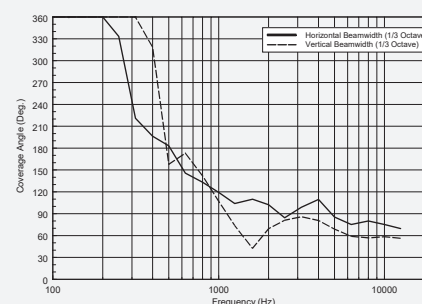

DIRECTIVITY INDEX AND Q

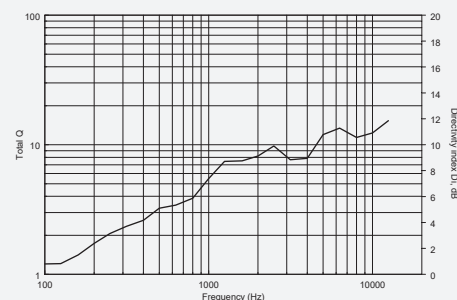

1) Measured on axis in the far field with 1 watt (2.83V RMS, 8 ohm) input and referenced to 1 meter distance using the inverse square law. Listed sound pressure represents an average from 300 Hz to 3 kHz.

2) Using 20 Hz to 20 kHz, Pink Noise Spectrum, 2 hours, + 6 dB crest factor, with RMS voltage calculated on speaker minimum impedance.

3) Recommended Amplifier is a power capability value that should be taken as a guide.

3108

COMPACT SERIES

C 3108-126 | C 3108-96

TWO-WAY PASSIVE SPEAKER

The system includes a high-level crossover network that features markedly lower (than conventional) induction values in series with the woofer. This innovation is named LICC ('Low Impedance Compensated Crossover': its benefits are delay reduction, reduced phase shift and superior transient response.

Dynamic high-frequency driver protection is accomplished with a new RCF exclusive - 'Active Mosfet Compression Driver Protection System' (AMCDP), chosen to complement the driver power curve.



/ CONNECTORS

Connections are made through two Neutrik Speakon NL4 connectors (audio input and parallel link output).

RELATED ACCESSORIES

	CL-BR NC	p.n. 133.60.217
Pipe clamp accessory. Adjustable inclination.		
	FL-BR NC 06-08-10	p.n. 133.60.200
Flying bracket accessory. Adjustable inclination.		
	H-BR 2X NC08	p.n. 133.60.190
Pair of horizontal brackets. Adjustable inclination.		
	V-BR 2X NC08	p.n. 133.60.195
Pair of vertical brackets. Adjustable inclination.		
	SWM-BR NC	p.n. 133.60.199
Wall mount swivel bracket.		



/ CABINET

The cabinet is made of Baltic birch (heavy duty painted) and allow different installation options, as it is equipped with top and bottom 'Multiplates' for either wall or suspended mounting with chains. Installation points are available on its rear panel as well. The steel front grille is protected with a double layer polyurethane fabric. The front RCF logo is easily rotatable.

APPLICATIONS

- Permanent Installations
- Main Reinforcement in small spaces
- Portable Systems AV Presentations
- Zone Delay and Fill Systems
- Under Balcony Applications



SPECIFICATIONS

C 3108-126

p.n.130.00.282

ACOUSTICAL

FREQ. RANGE (-10 dB):	70 Hz ÷ 20 kHz
HORIZ. COVERAGE ANGLE (-6 dB):	120°
VERTICAL COVERAGE ANGLE (-6 dB):	60°
DIRECTIVITY FACTOR Q:	9
SYSTEM SENSITIVITY:	94,5 dB
RATED MAXIMUM SPL:	125,5 dB
SYSTEM NOMINAL IMPEDANCE:	8 ohm
SYSTEM INPUT POWER RATING RMS:	300 W ⁽²⁾
SYSTEM INPUT POWER RATING PEAK:	1200 W
RECOMMENDED AMPLIFIER:	600 W ⁽³⁾
HF PROTECTION:	Dynamic
CROSSOVER:	2 kHz

TRANSDUCERS

LOW FREQUENCY:	8" (203 mm) woofer with 2" (50 mm) coil
NOMINAL IMPEDANCE:	8 ohm
INPUT POWER RATING:	200 W AES; 400 W Peak
SENSITIVITY:	94 dB, 1W @ 1m
HIGH FREQUENCY:	1" (25mm) throat, 1.5" (35,5mm) coil diaphragm assembly
NOMINAL IMPEDANCE:	8 ohm
INPUT POWER RATING:	25 W AES; 50 W Peak
SENSITIVITY:	106 dB, 1W @ 1m

PHYSICAL

ENCLOSURE:	12 mm birch plywood construction
RIGGING INSERTS:	6 x M8 (rear), 2 x M10 (side)
COLOR:	Black
GRILLE:	Custom perforated steel grille, epoxy powder coated, covered with polyurethane perforated cloth
INPUT CONNECTORS:	Speakon® NL4
DIMENSIONS (H x W x D):	16.81" x 9.52" x 10.35" 427 x 242 x 263 mm
WEIGHT:	26.46 lbs 12 kg

RESPONSE 1W/1m

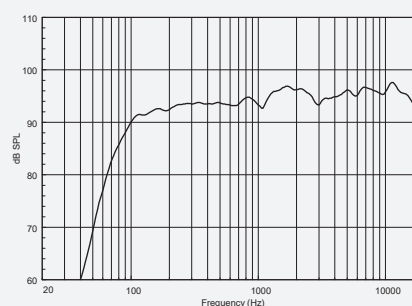

IMPEDANCE

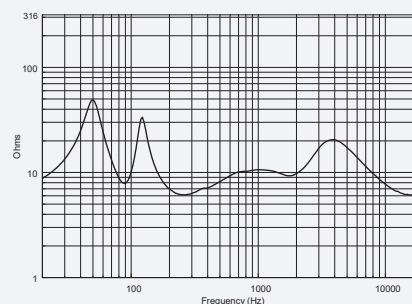

BEAMWIDTH vs. FREQUENCY

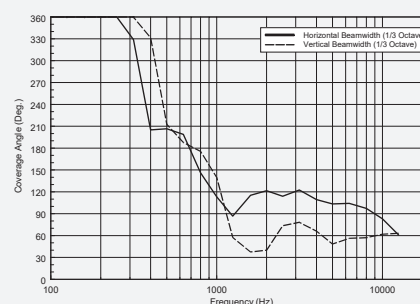

DIRECTIVITY INDEX AND Q

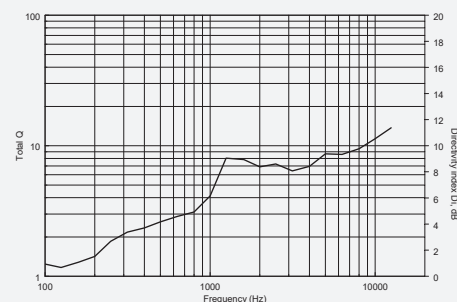

1) Measured on axis in the far field with 1 watt (2.83V RMS, 8 ohm) input and referenced to 1 meter distance using the inverse square law. Listed sound pressure represents an average from 300 Hz to 3 kHz.

2) Using 20 Hz to 20 kHz, Pink Noise Spectrum, 2 hours, + 6 dB crest factor, with RMS voltage calculated on speaker minimum impedance.

3) Recommended Amplifier is a power capability value that should be taken as a guide.

3108

COMPACT SERIES

C 3108-126 | C 3108-96

TWO-WAY PASSIVE SPEAKER

C 3108s are full range extremely versatile wide-dispersion, low-profile, two-way loudspeaker systems offering substantial power and efficiency for a variety of professional applications including permanent installations, main reinforcement in small spaces, plus portable systems and supplementary fill for larger systems. Their compact size makes them ideal for low visibility side wall or under balcony mounting.

RCF exclusive 'Constant Matching Design' technology helps guarantee an optimal transition between the high frequency horn polar pattern and the low frequency woofer directivity. The horn can be rotated, allowing to install the loudspeaker either vertically or horizontally.

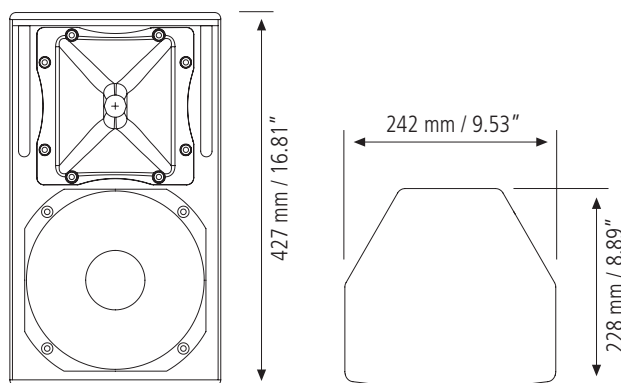

/ HIGH FREQUENCY

The hi-frequency transducer is a 1" RCF PRECISION compression driver with a 1.5" voice coil for smooth, wide dispersion.



/ LOW FREQUENCY

The low-frequency transducer is an 8" RCF PRECISION woofer with a 2" voice coil.

- CMD (Constant Matching Design) constant directivity horn
- 1" compression driver with 1.5" diaphragm assembly
- 8" woofer with 2" voice coil
- Rotatable Horn System for horizontal cabinet mounting applications
- HF driver AMCDP (Active Mosfet Compression Driver Protection)
- LICC (Low Impedance Compensated Crossover) network
- 8 Suspension points
- Omnimount™ 75 Plate fixing positions on rear of cabinet
- 35 mm standard internal pole mount





SPECIFICATIONS

C 3108-96

p.n.130.00.281

ACOUSTICAL

FREQ. RANGE (-10 dB):	70 Hz ÷ 20 kHz
HORIZ. COVERAGE ANGLE (-6 dB):	90°
VERTICAL COVERAGE ANGLE (-6 dB):	60°
DIRECTIVITY FACTOR Q:	11
SYSTEM SENSITIVITY:	95 dB
RATED MAXIMUM SPL:	126 dB
SYSTEM NOMINAL IMPEDANCE:	8 ohm
SYSTEM INPUT POWER RATING RMS:	300 W ⁽²⁾
SYSTEM INPUT POWER RATING PEAK:	1200 W
RECOMMENDED AMPLIFIER:	600 W ⁽³⁾
HF PROTECTION:	Dynamic
CROSSOVER:	2 kHz

TRANSDUCERS

LOW FREQUENCY:	8" (203 mm) woofer with 2" (50 mm) coil
NOMINAL IMPEDANCE:	8 ohm
INPUT POWER RATING:	200 W AES; 400 W Peak
SENSITIVITY:	94 dB, 1W @ 1m
HIGH FREQUENCY:	1" (25mm) throat, 1.5" (35,5mm) coil diaphragm assembly
NOMINAL IMPEDANCE:	8 ohm
INPUT POWER RATING:	25 W AES; 50 W Peak
SENSITIVITY:	106 dB, 1W @ 1m

PHYSICAL

ENCLOSURE:	12 mm birch plywood construction
RIGGING INSERTS:	6 x M8 (rear), 2 x M10 (side)
COLOR:	Black
GRILLE:	Custom perforated steel grille, epoxy powder coated, covered with polyurethane perforated cloth
INPUT CONNECTORS:	Speakon® NL4
DIMENSIONS (H x W x D):	16.81" x 9.52" x 10.35" 427 x 242 x 263 mm
WEIGHT:	29,9 lbs 12,2 kg

RESPONSE 1W/1m

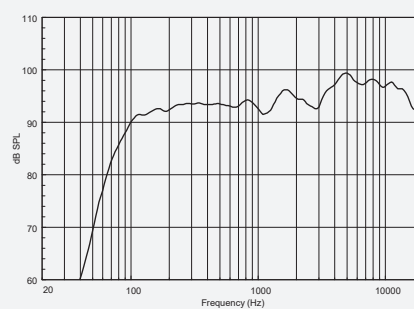

IMPEDANCE

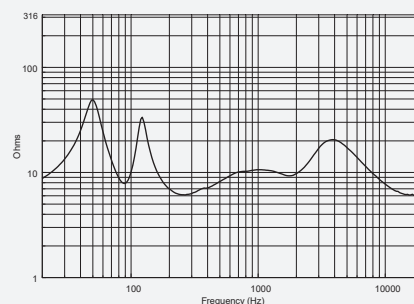

BEAMWIDTH vs. FREQUENCY

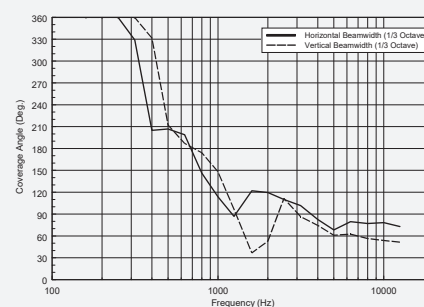

DIRECTIVITY INDEX AND Q

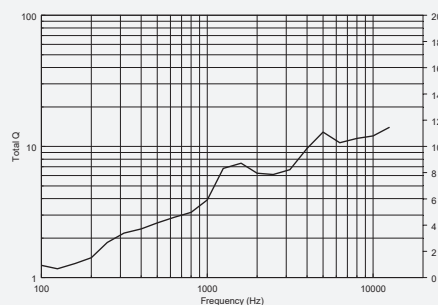

1) Measured on axis in the far field with 1 watt (2.83V RMS, 8 ohm) input and referenced to 1 meter distance using the inverse square law. Listed sound pressure represents an average from 300 Hz to 3 kHz.

2) Using 20 Hz to 20 kHz, Pink Noise Spectrum, 2 hours, + 6 dB crest factor, with RMS voltage calculated on speaker minimum impedance.

3) Recommended Amplifier is a power capability value that should be taken as a guide.

12

COMPACT M SERIES

COMPACT M 12

TWO-WAY PASSIVE SPEAKER

COMPACT M 12 is a multipurpose two-way full-range speaker system, suitable for a wide range of applications. The compactness, together with the elegant and neutral design with accurate finishing make M 12 suitable for almost any environment and architectural constraint. Its comfortable sound helps heavily in the near field applications. Optional mounting accessories allow using M 12 wall or ceiling mounted, to fit with several applications. The SPL and the level of undistorted sound M 12 can reach are far above any expectation from such a compact solution. M 12 features high sensitivity typical of professional audio cabinets thanks to the use of oversized magnets and an HI-FI sound quality with smooth and wide frequency response performed thanks to the waveguided neodymium dome tweeter. The crossover design includes a dynamic active mosfet protection on high frequency device.

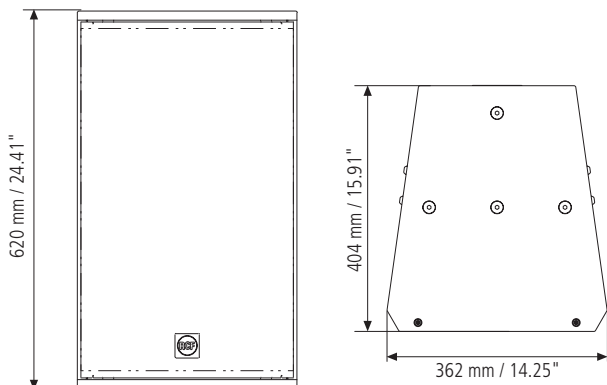

APPLICATIONS

- Multimedia Environments
- Conference Halls
- Pubs
- Café
- Foreground Business Music
- Delay Fill
- Place of Worships

- 300W AES power handling
- 129 dB max SPL
- 55 ÷ 20000 Hz frequency range
- 90° x 70° constant directivity coverage angle
- 1 x 12" high power woofer
- 1 x 1.4" voice coil compression driver
- High quality plywood cabinet
- Steel front grille with clothing
- Installation points available on rear, side, top and bottom panels
- 4 pole EUROBLOCK connector (audio input and parallel link output)

RELATED ACCESSORIES

PNL IN-OUT SPEAKON COMPACT M p.n. 123.99.062



The EUROBLOCK connection panel can be replaced with female Neutrik SpeakON connection panel in seconds, thanks to the single connector on the back.



H-BR 2X COMPACT M 12 p.n. 133.60.445

Pair of horizontal brackets for COMPACT M 12 speakers wall mounting.



V-BR 2X COMPACT M 12 p.n. 133.60.448

Pair of vertical brackets for COMPACT M 12 speakers wall mounting.

SUGGESTED PROCESSOR

DX 2006 p.n. 121.35.068



2 input, 6 output digital processor





SPECIFICATIONS

COMPACT M 12

p.n. 130.00.596

ACOUSTICAL

FREQ. RANGE (-10 dB):	55 Hz ÷ 20 kHz
HORIZ. COVERAGE ANGLE (-6 dB):	90°
VERTICAL COVERAGE ANGLE (-6 dB):	70°
DIRECTIVITY FACTOR Q:	9
SYSTEM SENSITIVITY:	98 dB, 1W @ 1m ⁽¹⁾
RATED MAXIMUM SPL:	129 dB, @ 1m
SYSTEM NOMINAL IMPEDANCE:	8 ohm
SYSTEM INPUT POWER RATING RMS:	300 W ⁽²⁾
SYSTEM INPUT POWER RATING PEAK:	1200 W
RECOMMENDED AMPLIFIER:	600 W ⁽³⁾
HF PROTECTION:	Dynamic
CROSSOVER:	1.8 kHz

TRANSDUCERS

LOW FREQUENCY:	12" (304 mm) woofer with 2.5" (63.5 mm) voice coil
NOMINAL IMPEDANCE:	8 ohm
INPUT POWER RATING:	300 W AES, 600 W PEAK
SENSITIVITY:	99 dB, 1W @ 1m
HIGH FREQUENCY:	1" (25 mm) throat, 1.4" (35 mm) voice coil
NOMINAL IMPEDANCE:	8 ohm
INPUT POWER RATING:	25 W AES, 50 W PEAK
SENSITIVITY:	107 dB, 1W @ 1m

PHYSICAL

ENCLOSURE:	Trapezoidal (angle: 8°), made of MDF (12 mm)
RIGGING INSERTS:	8 x M8, 8 x M10
COLOR:	Black
GRILLE:	Steel with clothing
INPUT CONNECTORS:	4-pin EUROBLOCK
DIMENSIONS (H x W x D):	24.41" x 14.25" x 15.91" 620 x 362 x 404 mm
WEIGHT:	48.5 lbs 22 kg

RESPONSE 1W/1m

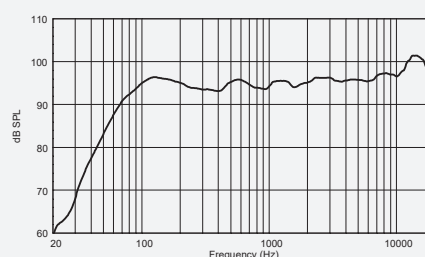

IMPEDANCE

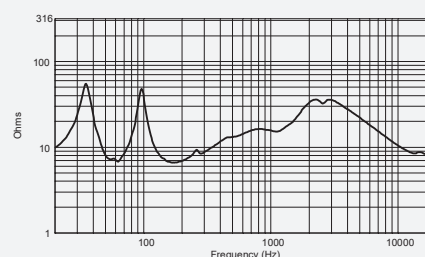

BEAMWIDTH vs. FREQUENCY

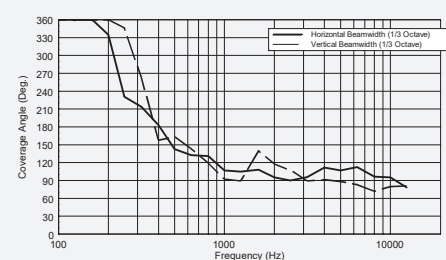

DIRECTIVITY INDEX AND Q

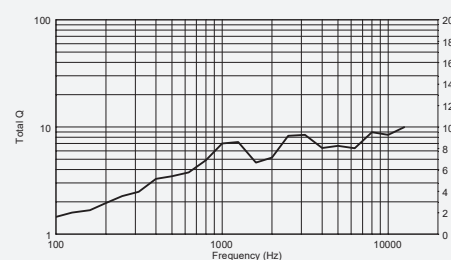

1) Measured on axis in the far field with 1 watt (2.83V RMS, 8 ohm) input and referenced to 1 meter distance using the inverse square law. Listed sound pressure represents an average from 300 Hz to 3 kHz.

2) Using 20 Hz to 20 kHz, Pink Noise Spectrum, 2 hours, + 6 dB crest factor, with RMS voltage calculated on speaker minimum impedance.

3) Recommended Amplifier is a power capability value that should be taken as a guide.

10

COMPACT M SERIES

COMPACT M 10

TWO-WAY PASSIVE SPEAKER

COMPACT M 10 is a multipurpose two-way full-range speaker system, suitable for a wide range of applications. The compactness, together with the elegant and neutral design with accurate finishing make M 10 suitable for almost any environment and architectural constraint. Its comfortable sound helps heavily in the near field applications. Optional mounting accessories allow using M 10 wall or ceiling mounted, to fit with several applications. The SPL and the level of undistorted sound M 10 can reach are far above any expectation from such a compact solution.

M 10 features high sensitivity typical of professional audio cabinets thanks to the use of oversized magnets and an HI-FI sound quality with smooth and wide frequency response performed thanks to the waveguided neodymium dome tweeter. The crossover design includes a dynamic active mosfet protection on high frequency device.

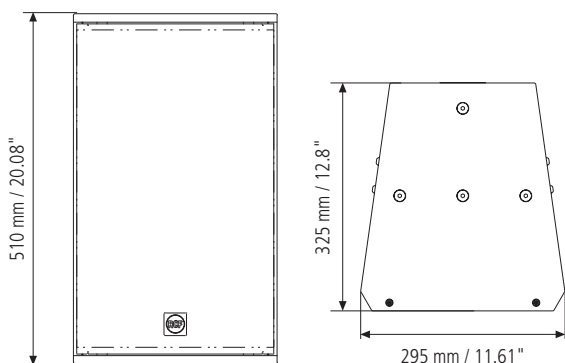

APPLICATIONS

- Multimedia Environments
- Conference Halls
- Pubs
- Café
- Foreground Business Music
- Delay Fill
- Place of Worships

- 300W AES power handling
- 128 dB max SPL
- 60 ÷ 20000 Hz frequency range
- 90° x 70° constant directivity coverage angle
- 1 x 10" high power woofer
- 1 x 1.4" voice coil compression driver
- High quality plywood cabinet
- Steel front grille with clothing
- Installation points available on rear, side, top and bottom panels
- 4 pole EUROBLOCK connector (audio input and parallel link output)

RELATED ACCESSORIES

PNL IN-OUT SPEAKON COMPACT M p.n. 123.99.062



The EUROBLOCK connection panel can be replaced with female Neutrik SpeakON connection panel in seconds, thanks to the single connector on the back.



H-BR 2X COMPACT M 10 p.n. 133.60.444

Pair of horizontal brackets for COMPACT M 10 speakers wall mounting.



V-BR 2X COMPACT M 10 p.n. 133.60.447

Pair of vertical brackets for COMPACT M 10 speakers wall mounting.

SUGGESTED PROCESSOR

DX 2006 p.n. 121.35.068



2 input, 6 output digital processor





SPECIFICATIONS

COMPACT M 10

p.n. 130.00.595

ACOUSTICAL

FREQ. RANGE (-10 dB):	60 Hz ÷ 20 kHz
HORIZ. COVERAGE ANGLE (-6 dB):	90°
VERTICAL COVERAGE ANGLE (-6 dB):	70°
DIRECTIVITY FACTOR Q:	9
SYSTEM SENSITIVITY:	98 dB, 1W @ 1m ⁽¹⁾
RATED MAXIMUM SPL:	128 dB, @ 1m
SYSTEM NOMINAL IMPEDANCE:	8 ohm
SYSTEM INPUT POWER RATING RMS:	300 W ⁽²⁾
SYSTEM INPUT POWER RATING PEAK:	1200 W
RECOMMENDED AMPLIFIER:	600 W ⁽³⁾
HF PROTECTION:	Dynamic
CROSSOVER:	1.8 kHz

TRANSDUCERS

LOW FREQUENCY:	10" (254 mm) woofer with 2.5" (63,5 mm) voice coil
NOMINAL IMPEDANCE:	8 ohm
INPUT POWER RATING:	300 W AES, 600 W PEAK
SENSITIVITY:	98 dB, 1W @ 1m
HIGH FREQUENCY:	1" (25 mm) throat, 1.4" (35 mm) voice coil
NOMINAL IMPEDANCE:	8 ohm
INPUT POWER RATING:	25 W AES, 50 W PEAK
SENSITIVITY:	107 dB, 1W @ 1m

PHYSICAL

ENCLOSURE:	Trapezoidal (angle: 8°), made of MDF (12 mm)
RIGGING INSERTS:	8 x M8, 8 x M10
COLOR:	Black
GRILLE:	Steel with clothing
INPUT CONNECTORS:	4-pin EUROBLOCK
DIMENSIONS (H x W x D):	20.08" x 11.61" x 12.8" 510 x 295 x 325 mm
WEIGHT:	37.48 lbs 17 kg

RESPONSE 1W/1m

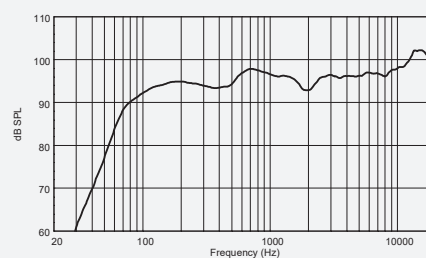

IMPEDANCE

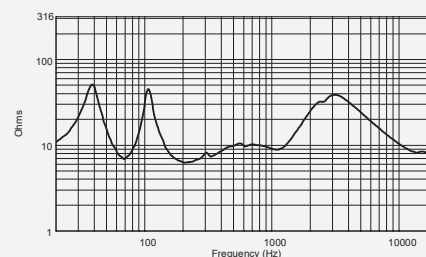

BEAMWIDTH vs. FREQUENCY

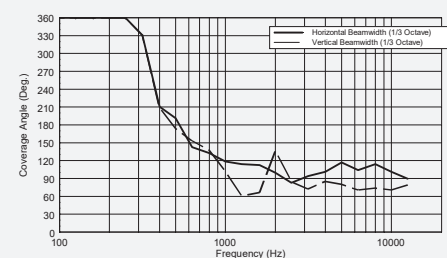

DIRECTIVITY INDEX AND Q

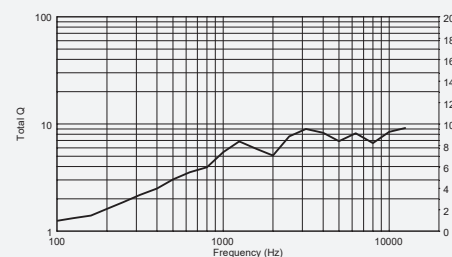

1) Measured on axis in the far field with 1 watt (2.83V RMS, 8 ohm) input and referenced to 1 meter distance using the inverse square law. Listed sound pressure represents an average from 300 Hz to 3 kHz.

2) Using 20 Hz to 20 kHz, Pink Noise Spectrum, 2 hours, + 6 dB crest factor, with RMS voltage calculated on speaker minimum impedance.

3) Recommended Amplifier is a power capability value that should be taken as a guide.

COMPACT M SERIES

COMPACT M 08

TWO-WAY PASSIVE SPEAKER

COMPACT M 08 is a multipurpose two-way full-range speaker system, suitable for a wide range of applications. The compactness, together with the elegant and neutral design with accurate finishing make M 08 suitable for almost any environment and architectural constraint. Its comfortable sound helps heavily in the near field applications. Optional mounting accessories allow using M 08 wall or ceiling mounted, to fit with several applications. The SPL and the level of undistorted sound M 08 can reach are far above any expectation from such a compact solution.

M 08 features high sensitivity typical of professional audio cabinets thanks to the use of oversized magnets and an HI-FI sound quality with smooth and wide frequency response performed thanks to the waveguided neodymium dome tweeter. The crossover design includes a dynamic active mosfet protection on high frequency device.

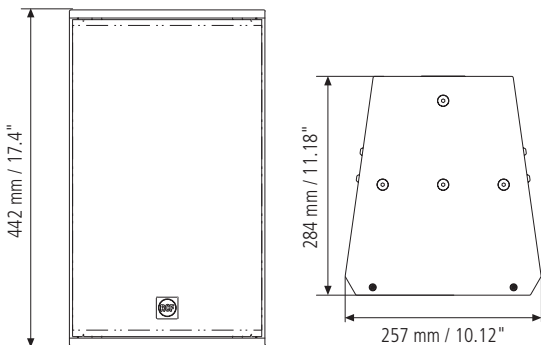

APPLICATIONS

- Multimedia Environments
- Conference Halls
- Pubs
- Café
- Foreground Business Music
- Delay Fill
- Place of Worships

- 180W AES power handling
- 124 dB max SPL
- 60 ÷ 20000 Hz frequency range
- 90° x 70° constant directivity coverage angle
- 1 x 8" high power woofer
- 1 x 1.4" voice coil compression driver
- High quality plywood cabinet
- Steel front grille with clothing
- Installation points available on rear, side, top and bottom panels
- 4 pole EUROBLOCK connector (audio input and parallel link output)

RELATED ACCESSORIES

PNL IN-OUT SPEAKON COMPACT M p.n. 123.99.062



The EUROBLOCK connection panel can be replaced with female Neutrik SpeakON connection panel in seconds, thanks to the single connector on the back.



H-BR 2X COMPACT M 08 p.n. 133.60.443

Pair of horizontal brackets for COMPACT M 08 speakers wall mounting.



V-BR 2X COMPACT M 08 p.n. 133.60.446

Pair of vertical brackets for COMPACT M 08 speakers wall mounting.



SWM-BR COMPACT M p.n. 133.60.449

Wall mount bracket.

SUGGESTED PROCESSOR

DX 2006 p.n. 121.35.068



2 input, 6 output digital processor





SPECIFICATIONS

COMPACT M 08

p.n. 130.00.594

ACOUSTICAL

FREQ. RANGE (-10 dB):	60 Hz ÷ 20 kHz
HORIZ. COVERAGE ANGLE (-6 dB):	90°
VERTICAL COVERAGE ANGLE (-6 dB):	70°
DIRECTIVITY FACTOR Q:	9
SYSTEM SENSITIVITY:	95 dB, 1W @ 1m ⁽¹⁾
RATED MAXIMUM SPL:	124 dB, @ 1m
SYSTEM NOMINAL IMPEDANCE:	8 ohm
SYSTEM INPUT POWER RATING RMS:	200 W ⁽²⁾
SYSTEM INPUT POWER RATING PEAK:	800 W
RECOMMENDED AMPLIFIER:	400 W ⁽³⁾
HF PROTECTION:	Dynamic
CROSSOVER:	1.8 kHz

TRANSDUCERS

LOW FREQUENCY:	8" (203 mm) woofer with 1.7" (43.2 mm) voice coil
NOMINAL IMPEDANCE:	8 ohm
INPUT POWER RATING:	200 W AES, 400 W PEAK
SENSITIVITY:	94 dB, 1W @ 1m
HIGH FREQUENCY:	1" (25 mm) throat, 1.4" (35.5 mm) voice coil
NOMINAL IMPEDANCE:	8 ohm
INPUT POWER RATING:	25 W AES, 50 W PEAK
SENSITIVITY:	107 dB, 1W @ 1m

PHYSICAL

ENCLOSURE:	Trapezoidal (angle: 8°), made of MDF (12 mm)
RIGGING INSERTS:	6 x M6, 4 x M8, 2 x M10
COLOR:	Black
GRILLE:	Steel with clothing
INPUT CONNECTORS:	4-pin EUROBLOCK
DIMENSIONS (H x W x D):	17.4" x 10.12" x 11.18" 442 x 257 x 284 mm
WEIGHT:	29.76 lbs 13.5 kg

RESPONSE 1W/1m

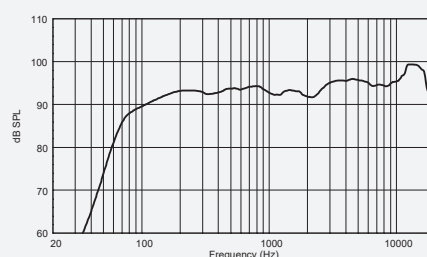

IMPEDANCE

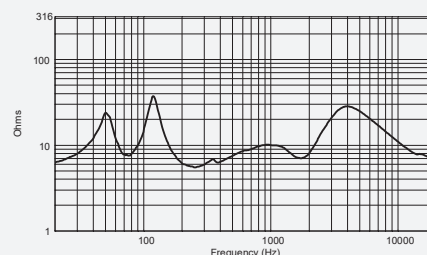

BEAMWIDTH vs. FREQUENCY

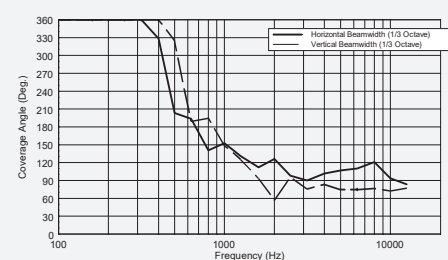

DIRECTIVITY INDEX AND Q

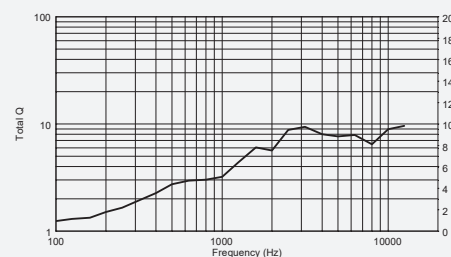

1) Measured on axis in the far field with 1 watt (2.83V RMS, 8 ohm) input and referenced to 1 meter distance using the inverse square law. Listed sound pressure represents an average from 300 Hz to 3 kHz.
 2) Using 20 Hz to 20 kHz, Pink Noise Spectrum, 2 hours, + 6 dB crest factor, with RMS voltage calculated on speaker minimum impedance.
 3) Recommended Amplifier is a power capability value that should be taken as a guide.

COMPACT M SERIES

COMPACT M 06

TWO-WAY PASSIVE SPEAKER

COMPACT M 06 is a multipurpose two-way full-range speaker system, suitable for a wide range of applications. The compactness, together with the elegant and neutral design with accurate finishing make M 06 suitable for almost any environment and architectural constraint. Its comfortable sound helps heavily in the near field applications. Optional mounting accessories allow using M 06 wall or ceiling mounted, to fit with several applications. The SPL and the level of undistorted sound M 06 can reach are far above any expectation from such a compact solution.

M 06 features high sensitivity typical of professional audio cabinets thanks to the use of oversized magnets and an HI-FI sound quality with smooth and wide frequency response performed thanks to the waveguided neodymium dome tweeter. The crossover design includes a dynamic active mosfet protection on high frequency device.

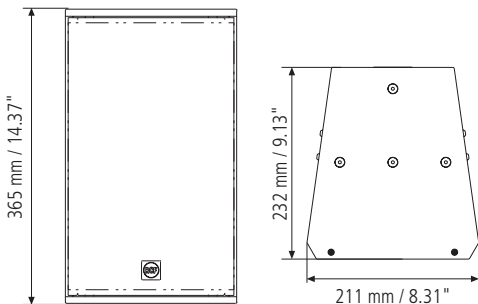

- 100W AES power handling
- 116 dB max SPL
- 60 ÷ 20000 Hz frequency range
- 120° x 80° constant directivity coverage angle
- 1 x 6" high power woofer
- 1 x 1" voice coil neodymium dome tweeter
- High quality plywood cabinet
- Steel front grille with clothing
- Installation points available on rear, top and bottom panels
- 4 pole EUROBLOCK connector (audio input and parallel link output)

RELATED ACCESSORIES

PNL IN-OUT SPEAKON COMPACT M p.n. 123.99.062



The EUROBLOCK connection panel can be replaced with female Neutrik SpeakON connection panel in seconds, thanks to the single connector on the back.



SWM-BR COMPACT M p.n. 133.60.449

Wall mount bracket.

SUGGESTED PROCESSOR

DX 2006 p.n. 121.35.068



2 input, 6 output digital processor

APPLICATIONS

- Multimedia Environments
- Conference Halls
- Pubs
- Background and Foreground Business Music
- Under-Balcony
- Delay Fill
- PA Systems
- Place of Worships
- Café





SPECIFICATIONS

COMPACT M 06

p.n. 130.00.582

ACOUSTICAL

FREQ. RANGE (-10 dB):	60 Hz ÷ 20 kHz
HORIZ. COVERAGE ANGLE (-6 dB):	120°
VERTICAL COVERAGE ANGLE (-6 dB):	80°
DIRECTIVITY FACTOR Q:	7
SYSTEM SENSITIVITY:	90 dB, 1W @ 1m ⁽¹⁾
RATED MAXIMUM SPL:	116 dB, @ 1m
SYSTEM NOMINAL IMPEDANCE:	8 ohm
SYSTEM INPUT POWER RATING RMS:	100 W ⁽²⁾
SYSTEM INPUT POWER RATING PEAK:	400 W
RECOMMENDED AMPLIFIER:	200 W ⁽³⁾
HF PROTECTION:	Dynamic
CROSSOVER:	2.2 kHz

TRANSDUCERS

LOW FREQUENCY:	6" (152 mm) woofer with 1.5" (38 mm) voice coil
NOMINAL IMPEDANCE:	8 ohm
INPUT POWER RATING:	100 W AES, 200 W PEAK
SENSITIVITY:	90 dB, 1W @ 1m
HIGH FREQUENCY:	1.3" (33 mm) throat, 1" (25 mm) voice coil
NOMINAL IMPEDANCE:	8 ohm
INPUT POWER RATING:	15 W AES, 30 W PEAK
SENSITIVITY:	92 dB, 1W @ 1m

PHYSICAL

ENCLOSURE:	Trapezoidal (angle: 8°), made of MDF (12 mm)
RIGGING INSERTS:	4 x M6, 2 x M8
COLOR:	Black
GRILLE:	Steel with clothing
INPUT CONNECTORS:	4-pin EUROBLOCK
DIMENSIONS (H x W x D):	14.37" x 8.31" x 9.13" 365 x 211 x 232 mm
WEIGHT:	12.13 lbs 5.5 kg

RESPONSE 1W/1m

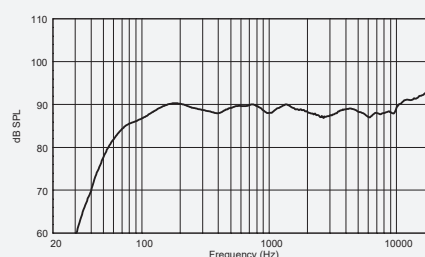

IMPEDANCE

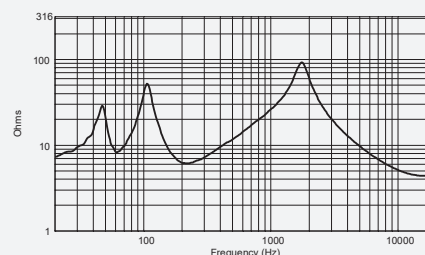

BEAMWIDTH vs. FREQUENCY

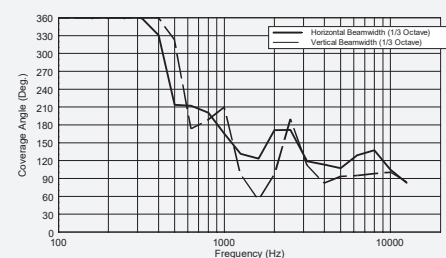

DIRECTIVITY INDEX AND Q

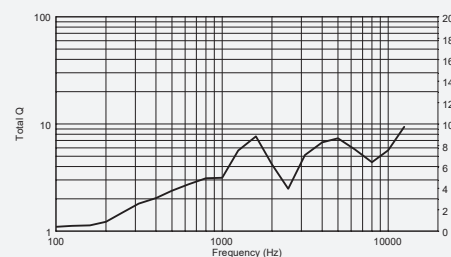

1) Measured on axis in the far field with 1 watt (2.83V RMS, 8 ohm) input and referenced to 1 meter distance using the inverse square law. Listed sound pressure represents an average from 300 Hz to 3 kHz.

2) Using 20 Hz to 20 kHz, Pink Noise Spectrum, 2 hours, + 6 dB crest factor, with RMS voltage calculated on speaker minimum impedance.

3) Recommended Amplifier is a power capability value that should be taken as a guide.

05 COMPACT M SERIES

COMPACT M 05

TWO-WAY PASSIVE SPEAKER

COMPACT M 05 is a multipurpose two-way full-range speaker system, suitable for a wide range of applications. The compactness, together with the elegant and neutral design with accurate finishing make M 05 suitable for almost any environment and architectural constraint. Its comfortable sound helps heavily in the near field applications. Optional mounting accessories allow using M 05 wall or ceiling mounted, to fit with several applications. The SPL and the level of undistorted sound M 05 can reach are far above any expectation from such a compact solution.

M 05 features high sensitivity typical of professional audio cabinets thanks to the use of oversized magnets and an HI-FI sound quality with smooth and wide frequency response performed thanks to the waveguided neodymium dome tweeter.

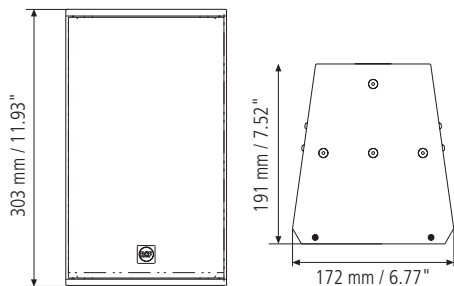

- 80W AES power handling
- 115 dB max SPL
- 70 ÷ 20000 Hz frequency range
- 120° x 80° constant directivity coverage angle
- 1 x 5" high power woofer
- 1 x 1" voice coil neodymium dome tweeter
- High quality plywood cabinet
- Steel front grille with clothing
- Installation points available on rear, top and bottom panels
- 4 pole EUROBLOCK connector (audio input and parallel link output)

RELATED ACCESSORIES

PNL IN-OUT SPEAKON COMPACT M p.n. 123.99.062



The EUROBLOCK connection panel can be replaced with female Neutrik SpeakON connection panel in seconds, thanks to the single connector on the back.

SWM-BR COMPACT M p.n. 133.60.449



Wall mount bracket.

SUGGESTED PROCESSOR

DX 2006 p.n. 121.35.068



2 input, 6 output digital processor

APPLICATIONS

- Multimedia Environments
- Conference Halls
- Pubs
- Background and Foreground Business Music
- Café
- Delay Fill
- Place of Worships
- PA Systems





SPECIFICATIONS

COMPACT M 05

p.n. 130.00.581

ACOUSTICAL

FREQ. RANGE (-10 dB):	70 Hz ÷ 20 kHz
HORIZ. COVERAGE ANGLE (-6 dB):	120°
VERTICAL COVERAGE ANGLE (-6 dB):	80°
DIRECTIVITY FACTOR Q:	7
SYSTEM SENSITIVITY:	89 dB, 1W @ 1m ⁽¹⁾
RATED MAXIMUM SPL:	115 dB, @ 1m
SYSTEM NOMINAL IMPEDANCE:	8 ohm
SYSTEM INPUT POWER RATING RMS:	80 W ⁽²⁾
SYSTEM INPUT POWER RATING PEAK:	320 W
RECOMMENDED AMPLIFIER:	160 W ⁽³⁾
HF PROTECTION:	-
CROSSOVER:	2.2 kHz

TRANSDUCERS

LOW FREQUENCY:	5" (127 mm) woofer with 1.2" (30 mm) voice coil
NOMINAL IMPEDANCE:	8 ohm
INPUT POWER RATING:	80 W AES, 160 W PEAK
SENSITIVITY:	89 dB, 1W @ 1m
HIGH FREQUENCY:	1.3" (33 mm) throat, 1" (25 mm) voice coil
NOMINAL IMPEDANCE:	8 ohm
INPUT POWER RATING:	15 W AES, 30 W PEAK
SENSITIVITY:	92 dB, 1W @ 1m

PHYSICAL

ENCLOSURE:	Trapezoidal (angle: 8°), made of MDF (12 mm)
RIGGING INSERTS:	4 x M6, 2 x M8
COLOR:	Black
GRILLE:	Steel with clothing
INPUT CONNECTORS:	4-pin EUROBLOCK
DIMENSIONS (H x W x D):	11.93" x 6.77" x 7.52" 303 x 172 x 191 mm
WEIGHT:	9.92 lbs 4.5 kg

RESPONSE 1W/1m

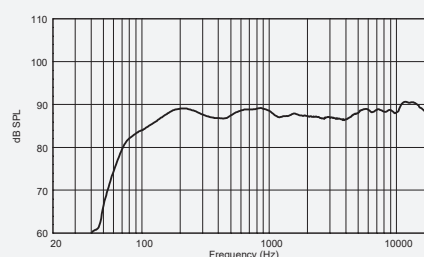

IMPEDANCE

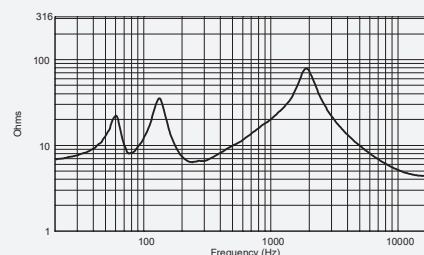

BEAMWIDTH vs. FREQUENCY

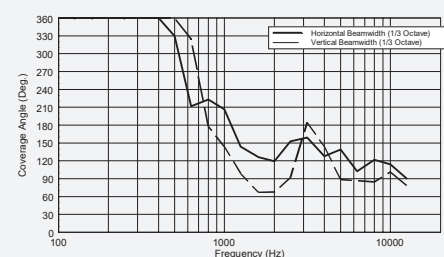

DIRECTIVITY INDEX AND Q

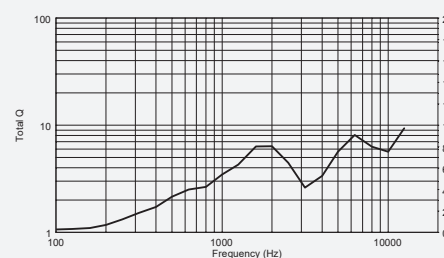

1) Measured on axis in the far field with 1 watt (2.83V RMS, 8 ohm) input and referenced to 1 meter distance using the inverse square law. Listed sound pressure represents an average from 300 Hz to 3 kHz.

2) Using 20 Hz to 20 kHz, Pink Noise Spectrum, 2 hours, + 6 dB crest factor, with RMS voltage calculated on speaker minimum impedance.

3) Recommended Amplifier is a power capability value that should be taken as a guide.

L SERIES

L 2406T

THREE WAY COLUMN SPEAKER SYSTEM

The L 2406T is a full range high intelligibility compact 3 way speaker column array with vertical controlled directivity. Providing very natural and intelligible speech and high quality music reproduction, it is the optimum choice for a variety of fixed applications where the critical acoustical environment or architectural constraints requires to control the vertical acoustic dispersion. It is equipped with six 5" woofers and four 1" dome tweeter. Its design with central tweeters mounted in front of the two central woofers permits coherent sound dispersion minimizing lobing and keeping the design very compact for a unit of its professional features. The two central woofers behind the tweeters are controlled differently from the other four low frequency transducers, providing a true cardioid column operation and improving the directivity.

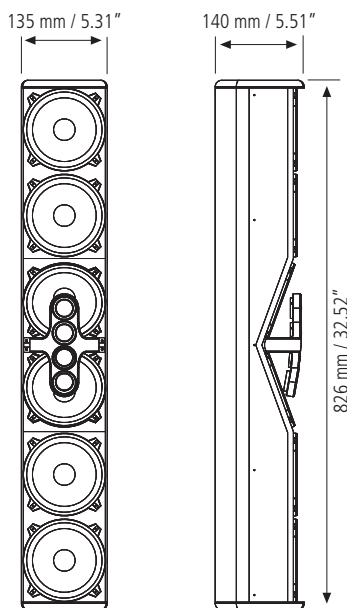

- 6 x 5" woofer, vented
- 4 x 1" in driver
- Controlled dispersion
- Speech enhancer filter
- LICC (Low Impedance Compensated Crossover)
- Built-in wall mounting accessories
- 200 W at 8 ohm; 60 W line transformer included

The wide coverage horizontal angle and the controlled vertical dispersion allows correct sound reproduction serving a wide area and assistance in limiting feedback and reverberated sound. A speech filter can be activated for enhancing the voice frequencies and improving speech intelligibility. The crossover is designed to avoiding secondary lobing creation. Mounting accessories are provided, they have been studied to keep the column as close as possible to the wall and simplify the installation allowing suitable tilting.

The L 2406T can be used connected to a low impedance amplifier: In this method it can handle 200 W RMS power. It also includes a 60 W line transformer for 100V systems. The crossover is equipped with a circuit to protect the four 1" dome tweeters.

APPLICATIONS

- Permanent Installations
- Speech reinforcement
- Transportation halls
- House of worships
- Critical environments
- Auditoriums
- Main Reinforcement in small spaces
- Zone Delay and Fill Systems





SPECIFICATIONS

L 2406T

p.n. 130.00.169 (Black) - 130.00.177 (White)

ACOUSTICAL

FREQ. RANGE (-10 dB):	100 Hz ÷ 20 kHz
HORIZ. COVERAGE ANGLE (-6 dB):	150°
VERTICAL COVERAGE ANGLE (-6 dB):	30°
DIRECTIVITY FACTOR Q:	9.25
SYSTEM SENSITIVITY:	97 dB, 1W @ 1m ⁽¹⁾
RATED MAXIMUM SPL:	126 dB, @ 1m
SYSTEM NOMINAL IMPEDANCE:	8 ohm
SYSTEM INPUT POWER RATING RMS:	300 W ⁽²⁾
SYSTEM INPUT POWER RATING PEAK:	1200 W
RECOMMENDED AMPLIFIER:	600 W ⁽³⁾
HF PROTECTION:	Dynamic
CROSSOVER:	2.0 kHz

TRANSDUCERS

LOW FREQUENCY:	6 x 5" (130 mm) woofer with 1" (25 mm) voice coil
NOMINAL IMPEDANCE:	16 ohm
INPUT POWER RATING:	30 W AES; 60 W Peak
SENSITIVITY:	90 dB, 1W @ 1m
HIGH FREQUENCY:	4 X 1" (25 mm) throat, 1" (25 mm) voice coil
NOMINAL IMPEDANCE:	8 ohm
INPUT POWER RATING:	10 W AES; 20 W Peak
SENSITIVITY:	90 dB, 1W @ 1m

PHYSICAL

ENCLOSURE:	Trapezoidal, 45° side angles 9 mm birch plywood construction
RIGGING INSERTS:	4 x M10
COLOR:	Black, white, scratch resistant paint
GRILLE:	Custom perforated steel grille
INPUT CONNECTORS:	EUROBLOCK
DIMENSIONS (H x W x D):	32.52" x 5.31" x 5.51" 826 x 135 x 140 mm
WEIGHT:	31.75 lbs 14.4 kg

RESPONSE 1W/1m

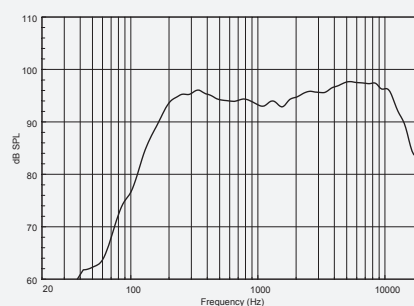

IMPEDANCE

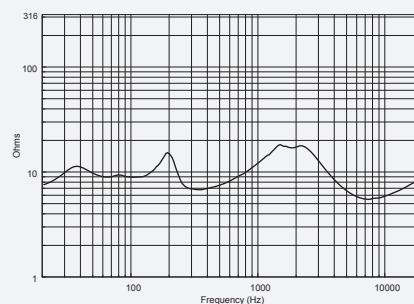

BEAMWIDTH vs. FREQUENCY

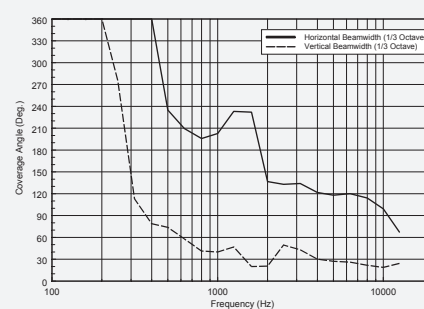

DIRECTIVITY INDEX AND Q

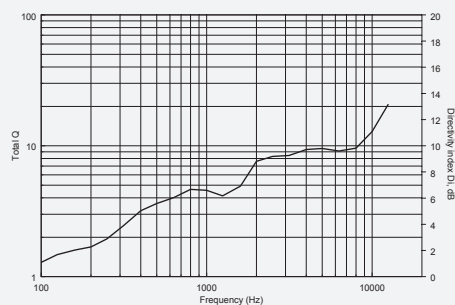

1) Measured on axis in the far field with 1 watt (2.83V RMS, 8 ohm) input and referenced to 1 meter distance using the inverse square law. Listed sound pressure represents an average from 300 Hz to 3 kHz.

2) Using 20 Hz to 20 kHz, Pink Noise Spectrum, 2 hours, + 6 dB crest factor, with RMS voltage calculated on speaker minimum impedance.

3) Recommended Amplifier is a power capability value that should be taken as a guide.

5228

P SERIES

P 5228-L

OUTDOOR/INDOOR TWO-WAY SPEAKER SYSTEM

The P 5228-L is an IP 55 (International Protection Rating) weatherproof full range, two-way line array loudspeaker module, offering substantial power and efficiency for a variety of professional indoor or outdoor applications.

The high frequency section includes two constant directivity CMD horn, each loaded with a 1" RCF Precision Neodymium compression driver with a 1.75" diaphragm assembly for smooth, wide horizontal dispersion and highly controlled 20° vertical coverage. The low-frequency transducers are two 8" woofers with a 2.5" voice coil.

The cabinet is a single piece rotational molded enclosure, made in medium density polyethylene, fully UV protected equipped with 4 x M8 brass inserts and a stainless steel U-Bracket.

Connections to the amplifier are made through a watertight multi-pole connector. The grille is in custom perforated aluminum with open-cell fibers and water repellent woven fabric backing.

- Weatherproof cabinet IP55
- Aluminium grill and stainless steel bracket
- Two 8" high-output LF transducers with 2.5" voice coil
- Two RCF Precision Neodymium 1" compression driver with 1.75" diaphragm assembly
- 90° x 20° constant directivity horn
- 2° x 15° enclosure sides for array configurations
- Active Mosfet Compression Driver Protection
- LICC (Low Impedance Compensated Crossover) network
- Input connector 4 pole Amphenol IP 67

RELATED ACCESSORIES



C-BR 2X P28

p.n. 133.60.119

Cluster brackets for P 5228-L
(including 4 brackets to cluster 2 speakers)

SUGGESTED PROCESSOR

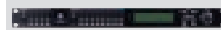

DX 4008

p.n. 121.35.033

4 inputs, 8 output digital processor

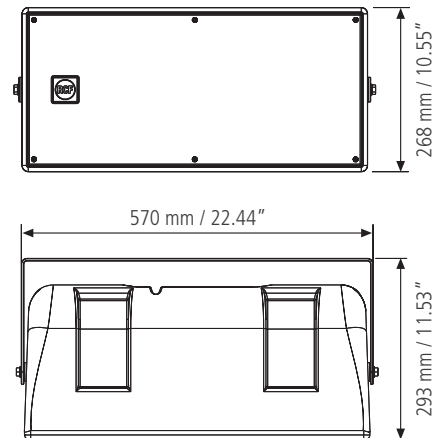

APPLICATIONS

- Outdoor sound reinforcement in medium-large spaces
- High level AV playback
- Flown cluster configurations
- Large speech systems
- Music sound reinforcement





SPECIFICATIONS

P 5228-L

p.n. 130.00.202

ACOUSTICAL

FREQ. RANGE (-10 dB):	80 Hz ÷ 20 kHz
FREQ. RANGE (-3 dB):	100 Hz ÷ 20 kHz
HORIZ. COVERAGE ANGLE (-6 dB):	90°
VERTICAL COVERAGE ANGLE (-6 dB):	20°
DIRECTIVITY FACTOR Q:	11
SYSTEM SENSITIVITY:	98 dB, 1W @ 1m ⁽¹⁾
RATED MAXIMUM SPL:	131 dB, @ 1m
SYSTEM NOMINAL IMPEDANCE:	8 ohm
SYSTEM INPUT POWER RATING RMS:	500 W ⁽²⁾
SYSTEM INPUT POWER RATING PEAK:	2000 W
RECOMMENDED AMPLIFIER:	1000 W ⁽³⁾
HF PROTECTION:	Dynamic
CROSSOVER:	1.3 kHz

TRANSDUCERS

LOW FREQUENCY:	2 x 8" (203 mm) woofer with 2.5" (63.5 mm) voice coil
NOMINAL IMPEDANCE:	16 ohm
INPUT POWER RATING:	300 W AES; 600 W Peak
SENSITIVITY:	95 dB, 1W @ 1m
HIGH FREQUENCY:	2 x 1" (25 mm) throat, 1.75" (44.5 mm) voice coil
NOMINAL IMPEDANCE:	16 ohm
INPUT POWER RATING:	50 W AES; 200 W Peak
SENSITIVITY:	109 dB, 1W @ 1m

PHYSICAL

ENCLOSURE:	Trapezoidal, 2° Horizontal side angles, 15° Vertical side angle, 8 mm Polyethylene rotomoulded
RIGGING INSERTS:	4 x M8 + U-brackets and pair of spacers
COLOR:	Grey
GRILLE:	Custom perforated aluminium grille with open-cell fiber and water repellent woven fabric backing
INPUT CONNECTORS:	4 pole Amphenol
DIMENSIONS (H x W x D):	10.55" x 22.28" x 16.23" 268 x 566 x 250 mm
WEIGHT:	30.8 lb 14 kg

RESPONSE 1W/1m

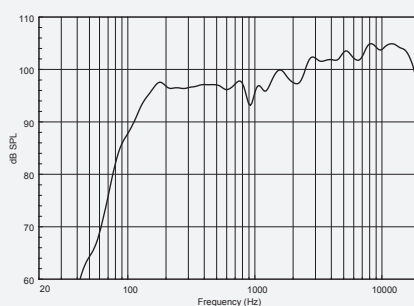

IMPEDANCE

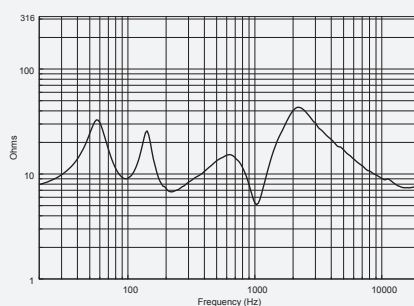

BEAMWIDTH vs. FREQUENCY

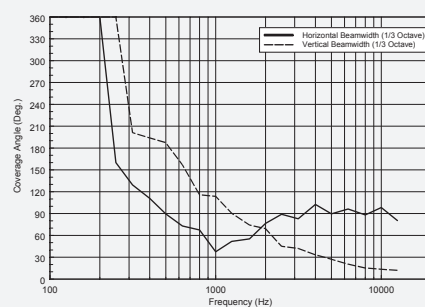

DIRECTIVITY INDEX AND Q

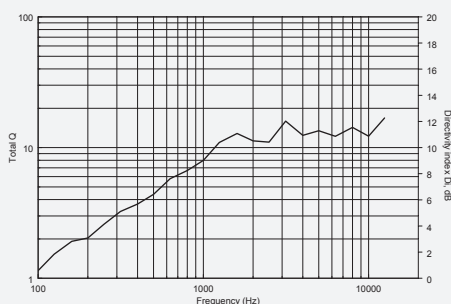

1) Measured on axis in the far field with 1 watt (2.83V RMS, 8 ohm) input and referenced to 1 meter distance using the inverse square law. Listed sound pressure represents an average from 300 Hz to 3 kHz.

2) Using 20 Hz to 20 kHz, Pink Noise Spectrum, 2 hours, + 6 dB crest factor, with RMS voltage calculated on speaker minimum impedance.

3) Recommended Amplifier is a power capability value that should be taken as a guide.

4228

P SERIES

P 4228

OUTDOOR/INDOOR TWO-WAY SPEAKER SYSTEM

The P 4228 is a weatherproof full range, wide-dispersion, two-ways loudspeaker system offering substantial power and efficiency for a variety of professional indoor or outdoor applications.

The highfrequency section is a constant directivity CMD horn loaded with a 1.4" RCF Precision Neodymium compression driver with a 2.5" diaphragm assembly for smooth, wide dispersion.

The low-frequency transducer is a double 8" woofer with a 2.5" voice coil. The cabinet is a single piece rotational moulded in medium density polyethylene, fully UV protected.

The cabinet is equipped with 4 x M8 brass inserts, a stainless steel U-Bracket. The front logo is in aluminium and rotatable.

The grille is in custom perforated aluminium with open-cell fibres and water repellent woven fabric backing.

P 4228 is suitable for indoor and outdoor applications/installations, it meets the requirements of IP 55 code (International Protection Rating).

- Weatherproof cabinet IP 55
- Aluminium grill and stainless steel bracket
- Two 8" high-output LF transducer with 2.5" voice coil
- One RCF Precision Neodymium 1.4" Compression Driver with 2.5" voice coil
- 110° x 60° constant directivity horn
- 2° X 15° enclosure sides for array configurations
- Active Mosfet Compression Driver Protection
- LICC (Low Impedance Compensated Crossover) network
- Input connector 4 pole Amphenol IP 67

RELATED ACCESSORIES

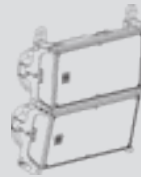

C-BR 2X P28

p.n. 133.60.119

Cluster brackets for P 4228
(including 4 brackets to cluster 2 speakers)

SUGGESTED PROCESSOR

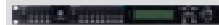

DX 4008

p.n. 121.35.033

4 inputs, 8 output digital processor

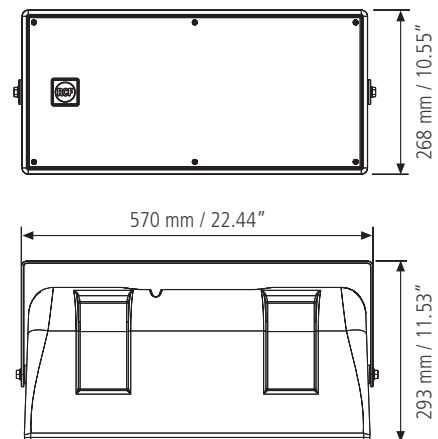

APPLICATIONS

- Outdoor Sound Reinforcement in small and medium spaces
- High-Level AV Playback
- Flown cluster configurations
- Large speech systems
- Music Sound Reinforcement





SPECIFICATIONS

P 4228

p.n. 130.00.199

ACOUSTICAL

FREQ. RANGE (-10 dB):	80 Hz ÷ 20 kHz
FREQ. RANGE (-3 dB):	100 Hz ÷ 20 kHz
HORIZ. COVERAGE ANGLE (-6 dB):	110°
VERTICAL COVERAGE ANGLE (-6 dB):	60°
DIRECTIVITY FACTOR Q:	9
SYSTEM SENSITIVITY:	97 dB, 1W @ 1m ⁽¹⁾
RATED MAXIMUM SPL:	129 dB, @ 1m
SYSTEM NOMINAL IMPEDANCE:	8 ohm
SYSTEM INPUT POWER RATING RMS:	400 W ⁽²⁾
SYSTEM INPUT POWER RATING PEAK:	1600 W
RECOMMENDED AMPLIFIER:	800 W ⁽³⁾
HF PROTECTION:	Dynamic
CROSSOVER:	1.1 kHz

TRANSDUCERS

LOW FREQUENCY:	2 x 8" (203 mm) woofer with 2.5" (63.5 mm) voice coil
NOMINAL IMPEDANCE:	16 ohm
INPUT POWER RATING:	300 W AES; 1200 W Peak
SENSITIVITY:	95 dB, 1W @ 1m
HIGH FREQUENCY:	1.4" (35.6 mm) throat, 2.5" (63.5 mm) voice coil
NOMINAL IMPEDANCE:	8 ohm
INPUT POWER RATING:	90 W AES; 360 W Peak
SENSITIVITY:	110 dB, 1W @ 1m

PHYSICAL

ENCLOSURE:	Trapezoidal, 2° Horizontal side angles, 15° Vertical side angle, 8 mm Polyethylene rotomoulded
RIGGING INSERTS:	4 x M8 + U-brackets and pair of spacers
COLOR:	Grey
GRILLE:	Custom perforated aluminium grille with open-cell fiber and water repellent woven fabric backing
INPUT CONNECTORS:	4 pole Amphenol
DIMENSIONS (H x W x D):	10.55" x 22.28" x 16.23" 268 x 566 x 250 mm
WEIGHT:	30.8 lb 14 kg

RESPONSE 1W/1m

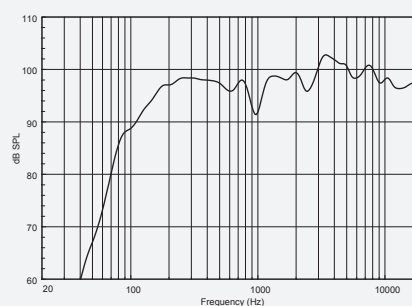

IMPEDANCE

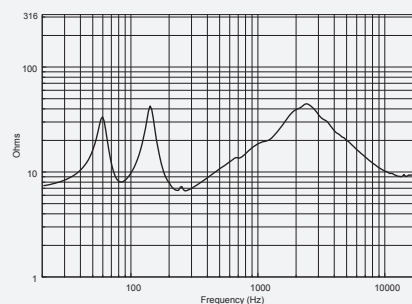

BEAMWIDTH vs. FREQUENCY

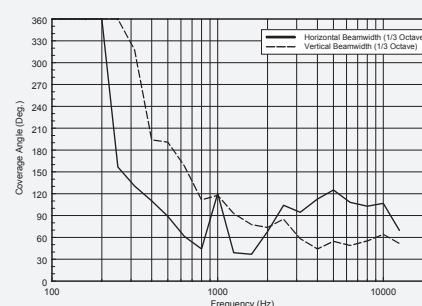

DIRECTIVITY INDEX AND Q

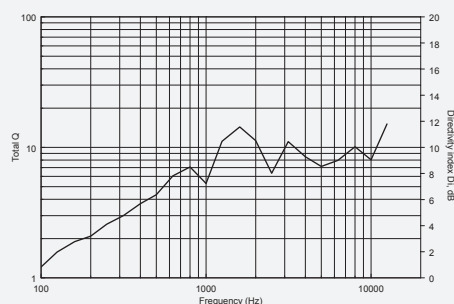

1) Measured on axis in the far field with 1 watt (2.83V RMS, 8 ohm) input and referenced to 1 meter distance using the inverse square law. Listed sound pressure represents an average from 300 Hz to 3 kHz.

2) Using 20 Hz to 20 kHz, Pink Noise Spectrum, 2 hours, + 6 dB crest factor, with RMS voltage calculated on speaker minimum impedance.

3) Recommended Amplifier is a power capability value that should be taken as a guide.

3108

P SERIES

P 3108

OUTDOOR/INDOOR TWO-WAY SPEAKER SYSTEM

The P 3108 is a weatherproof full range, wide-dispersion, two-way loudspeaker system offering substantial power and efficiency for a variety of professional indoor or outdoor applications.

P 3108 high frequency section is a constant directivity CMD horn loaded with a 1" RCF Precision compression driver with a 1.50" diaphragm assembly for a smooth, wide dispersion. The low-frequency transducer is a 8" woofer with a 2.5" voice coil. The cabinet is a single piece rotational moulded in medium density polyethylene, fully UV protected. The cabinet is equipped with 4 x M8 brass inserts and a stainless steel U-Bracket.

The front logo is in aluminium and rotatable. The grille is in custom perforated aluminium with open-cell fibres and water repellent woven fabric backing.

P 3108 is suitable for indoor and outdoor applications/installations, it meets the requirements of IP 55 code (International Protection Rating).

- Weatherproof cabinet IP 55
- Aluminium grill and stainless steel bracket
- One 8" high-output LF transducer; 2.5" voice coil
- One RCF Precision 1" Compression Driver with 1.5" voice coil
- 90° x 60° constant directivity horn
- 2° x 15° enclosure sides for cluster configurations
- Active Mosfet Compression Driver Protection
- LICC (Low Impedance Compensated Crossover) network

RELATED ACCESSORIES

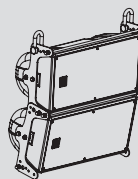

AC P08 A-BR

p.n. 133.60.118

Cluster brackets for P 3108 and P 1108T
(including 4 brackets to cluster 2 speakers)

SUGGESTED PROCESSOR



DX 4008

p.n. 121.35.033

4 inputs, 8 output digital processor

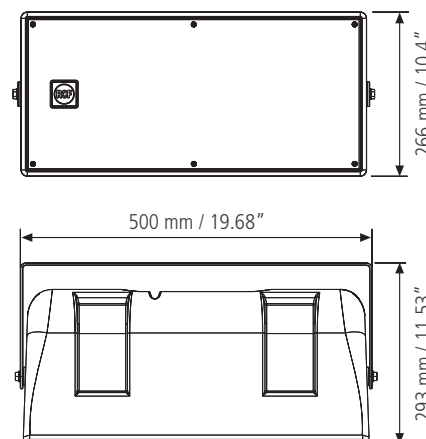

APPLICATIONS

- Outdoor Sound Reinforcement in small and medium spaces
- High-Level AV Playback
- Flown cluster configurations
- Large speech systems
- Music Sound Reinforcement





SPECIFICATIONS

P 3108

p.n. 130.00.198

ACOUSTICAL

FREQ. RANGE (-10 dB):	80 Hz ÷ 20 kHz
FREQ. RANGE (-3 dB):	100 Hz ÷ 20 kHz
HORIZ. COVERAGE ANGLE (-6 dB):	90°
VERTICAL COVERAGE ANGLE (-6 dB):	60°
DIRECTIVITY FACTOR Q:	11
SYSTEM SENSITIVITY:	94 dB, 1W @ 1m ⁽¹⁾
RATED MAXIMUM SPL:	125 dB, @ 1m
SYSTEM NOMINAL IMPEDANCE:	8 ohm
SYSTEM INPUT POWER RATING RMS:	300 W ⁽²⁾
SYSTEM INPUT POWER RATING PEAK:	1200 W
RECOMMENDED AMPLIFIER:	600 W ⁽³⁾
HF PROTECTION:	Dynamic
CROSSOVER:	1.8 kHz

TRANSDUCERS

LOW FREQUENCY:	8" (203 mm) woofer with 2.5" (63.5 mm) voice coil
NOMINAL IMPEDANCE:	8 ohm
INPUT POWER RATING:	300 W AES; 1200 W Peak
SENSITIVITY:	95 dB, 1W @ 1m
HIGH FREQUENCY:	1" (25 mm) throat, 2.5" (63.5 mm) voice coil
NOMINAL IMPEDANCE:	8 ohm
INPUT POWER RATING:	25 W AES; 100 W Peak
SENSITIVITY:	109 dB, 1W @ 1m

PHYSICAL

ENCLOSURE:	Trapezoidal, 2° Horizontal side angles, 15° Vertical side angle, 8 mm Polyethylene rotomoulded
RIGGING INSERTS:	4 x M8 + U-Bracket and Pair of spacers
COLOR:	Grey
GRILLE:	Custom perforated aluminium grille with open-cell fiber and water repellent woven fabric backing
INPUT CONNECTORS:	4 pole Amphenol
DIMENSIONS (H x W x D):	10.4" x 19.4" x 16.2" 266 x 493 x 250 mm
WEIGHT:	22 lb 10 kg

RESPONSE 1W/1m

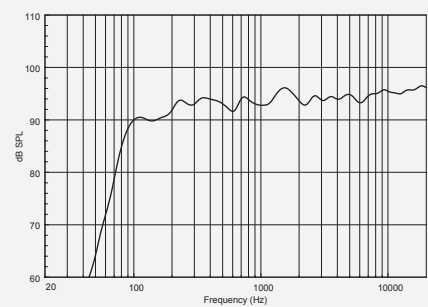

IMPEDANCE

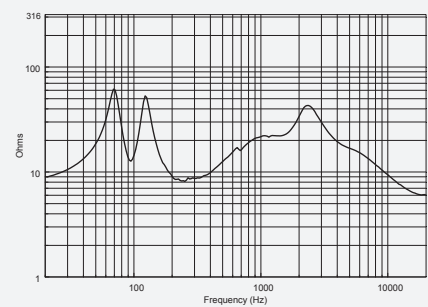

BEAMWIDTH vs. FREQUENCY

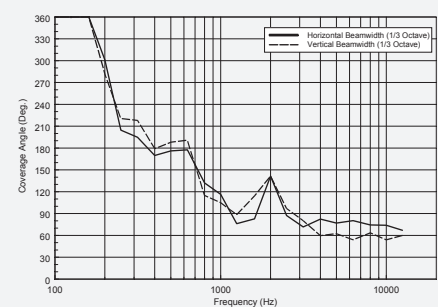

DIRECTIVITY INDEX AND Q

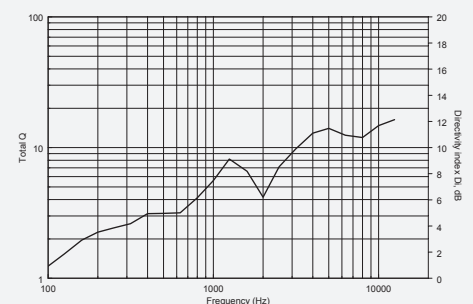

1) Measured on axis in the far field with 1 watt (2.83V RMS, 8 ohm) input and referenced to 1 meter distance using the inverse square law. Listed sound pressure represents an average from 300 Hz to 3 kHz.

2) Using 20 Hz to 20 kHz, Pink Noise Spectrum, 2 hours, + 6 dB crest factor, with RMS voltage calculated on speaker minimum impedance.

3) Recommended Amplifier is a power capability value that should be taken as a guide.

1108

P SERIES

P 1108T

OUTDOOR/INDOOR TWO-WAY SPEAKER SYSTEM

The P 1108T is a weatherproof full range, wide-dispersion, two-way loudspeaker system suitable for several indoor or outdoor applications where good speech intelligibility and music reproduction are required.

In a single-piece rotational moulded UV protected polyethylene cabinet the P 1108T combines a 1,5" diaphragm assembly compression driver loaded on a 1" rotatable constant directivity 90°x60°CD horn with a 8" high efficiency low-frequency transducer with a 1.5" voice coil.

The cabinet is equipped with 4 x M 8 brass inserts and a steel U-Bracket. The front logo is in aluminium and rotatable. The grille is in custom perforated aluminium with open-cell fibres and water repellent woven fabric backing. P 1108T is suitable for indoor and outdoor installations, it meets the requirements of IP 55 code (International Protection Rating).

- Weatherproof cabinet IP 55
- Aluminium grill and stainless steel bracket
- One 8" high-output LF transducer; 1.5" voice coil
- One RCF Precision 1" Compression Driver with 1.5" voice coil
- 90° x 60° constant directivity horn
- 2° x 15° enclosure sides for cluster configurations
- Active Mosfet Compression Driver Protection
- LICC (Low Impedance Compensated Crossover) network
- 2 metres 4 x 1.5 Input cable

SUGGESTED PROCESSOR

DX 4008

p.n. 121.35.033

4 inputs, 8 output digital processor

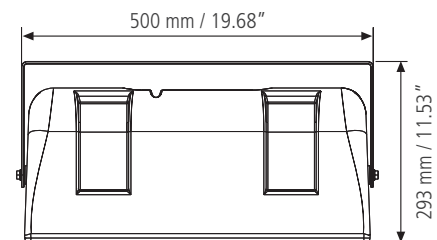
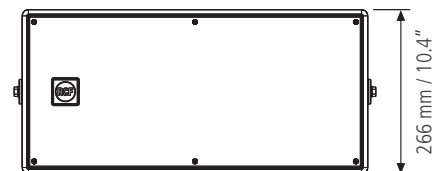

APPLICATIONS

- Outdoor Sound Reinforcement in small and medium spaces
- Sound Reinforcement in outdoor and indoor applications
- High-Level AV Playback- AV Playback
- Flown cluster configurations
- Large speech systems
- Music Sound Reinforcement
- Voice and Music reproduction





SPECIFICATIONS

P 1108T

p.n. 130.00.203

ACOUSTICAL

FREQ. RANGE (-10 dB):	80 Hz ÷ 20 kHz
FREQ. RANGE (-3 dB):	110 Hz ÷ 20 kHz
HORIZ. COVERAGE ANGLE (-6 dB):	90°
VERTICAL COVERAGE ANGLE (-6 dB):	60°
DIRECTIVITY FACTOR Q:	11
SYSTEM SENSITIVITY:	95 dB, 1W @ 1m ⁽¹⁾
RATED MAXIMUM SPL:	121 dB, @ 1m
SYSTEM NOMINAL IMPEDANCE:	16 ohm
SYSTEM INPUT POWER RATING RMS:	100 W ⁽²⁾
SYSTEM INPUT POWER RATING PEAK:	400 W
RECOMMENDED AMPLIFIER:	200 W ⁽³⁾
CONSTANT VOLTAGE LINE:	70/100 V
SELECTABLE POWER:	70V/30W, 15W - 100V/60W, 30W
HF PROTECTION:	PTC
CROSSOVER:	2.2 kHz

TRANSDUCERS

LOW FREQUENCY:	8" (203 mm) woofer with 1.5" (38 mm) voice coil
NOMINAL IMPEDANCE:	16 ohm
INPUT POWER RATING:	100 W AES; 400 W Peak
SENSITIVITY:	94 dB, 1W @ 1m
HIGH FREQUENCY:	1" (25 mm) throat, 1.5" (38 mm) voice coil
NOMINAL IMPEDANCE:	8 ohm
INPUT POWER RATING:	20 W AES; 80 W Peak
SENSITIVITY:	107 dB, 1W @ 1m

PHYSICAL

ENCLOSURE:	Trapezoidal, 2° Horizontal side angles, 15° Vertical side angle, 8 mm Polyethylene rotomoulded
RIGGING INSERTS:	4 x M8 + U-Bracket and Pair of spacers
COLOR:	Grey
GRILLE:	Custom perforated aluminium grille with open-cell fiber and water repellent woven fabric backing
INPUT CONNECTORS:	4 x 1.5 mm square 2m Neoprene cable
DIMENSIONS (H x W x D):	10.4" x 19.4" x 16.2" 266 x 493 x 250 mm
WEIGHT:	26.01 lb 11.8 kg

RESPONSE 1W/1m

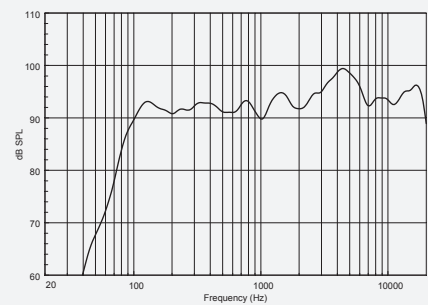

IMPEDANCE

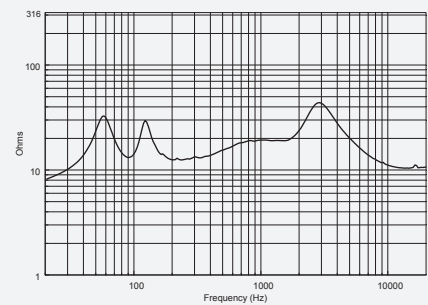

BEAMWIDTH vs. FREQUENCY

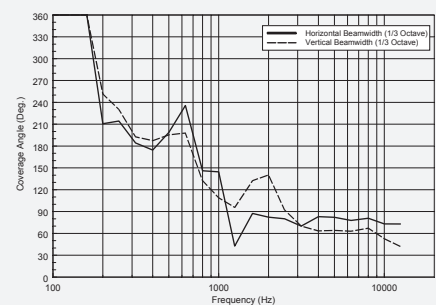

DIRECTIVITY INDEX AND Q

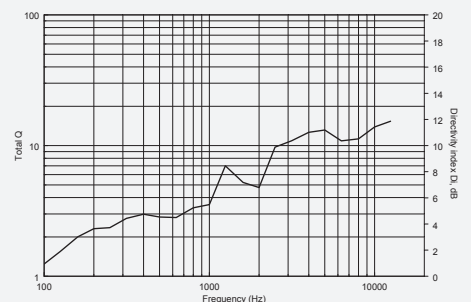

1) Measured on axis in the far field with 1 watt (2.83V RMS, 8 ohm) input and referenced to 1 meter distance using the inverse square law. Listed sound pressure represents an average from 300 Hz to 3 kHz.

2) Using 20 Hz to 20 kHz, Pink Noise Spectrum, 2 hours, + 6 dB crest factor, with RMS voltage calculated on speaker minimum impedance.

3) Recommended Amplifier is a power capability value that should be taken as a guide.

P SERIES

P 6215

OUTDOOR/INDOOR TWO-WAY COAXIAL SPEAKER SYSTEM

The P 6215 is a weatherproof full range, wide-dispersion, coaxial two-way loudspeaker system offering substantial power and efficiency for a variety of professional indoor or outdoor applications.

P 6215 high-frequency section is a constant directivity CMD horn loaded to a 1.3" RCF Precision Neodymium compression driver with a 2.5" diaphragm assembly for smooth, wide dispersion. The low-frequency transducer is a 15" woofer with a 3" voice coil. The P6215 is a dedicated high power version for very high output and longer throw applications.

The cabinet is a single piece rotational moulded in medium density polyethylene, fully UV protected. The cabinet is equipped with 12 x M10 brass inserts, a stainless steel U-Bracket and pair of spacers for 90° mounting. The front logo is in aluminium and rotatable. The grille is in custom perforated aluminium with open-cell fibres and water repellent woven fabric backing. Both P6215 is suitable for indoor and outdoor applications/installations, they meet the requirements of IP 55 code (International Protection Rating).

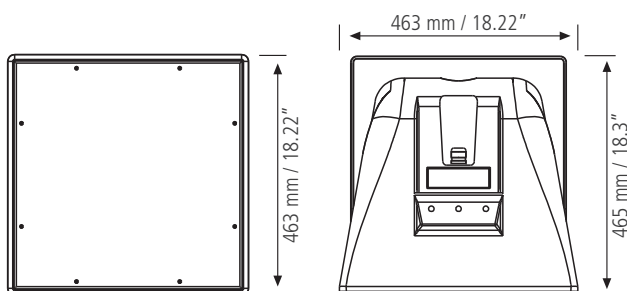

APPLICATIONS

- Outdoor Sound Reinforcement in medium and large spaces
- Very High-Level AV Playback
- Flown cluster configurations
- Large speech systems
- Music Sound Reinforcement



RELATED ACCESSORIES

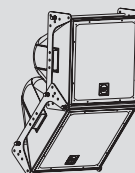

C-BR 2X P15

p.n. 133.60.094

Kit including 4 cluster brackets for P 6215
(4 brackets cluster 2 speakers)

SUGGESTED PROCESSOR

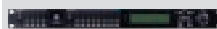

DX 4008

p.n. 121.35.033

4 inputs, 8 output digital processor



- Weatherproof cabinet IP 55
- Aluminium grill and stainless steel bracket
- One 15" high-output LF transducer with 3" voice coil
- One RCF Precision 1" C. Driver with 2.5" voice coil
- 60° x 60° constant directivity horn
- 10° X 20° enclosure sides for array configurations
- Active Mosfet Compression Driver Protection



SPECIFICATIONS

P 6215

p.n. 130.00.131

ACOUSTICAL

FREQ. RANGE (-10 dB):	75 Hz ÷ 20 kHz
FREQ. RANGE (-3 dB):	120 Hz ÷ 20 kHz
HORIZ. COVERAGE ANGLE (-6 dB):	60°
VERTICAL COVERAGE ANGLE (-6 dB):	60°
DIRECTIVITY FACTOR Q:	12.8
SYSTEM SENSITIVITY:	100 dB, 1W @ 1m ⁽¹⁾
RATED MAXIMUM SPL:	134 dB, @ 1m
SYSTEM NOMINAL IMPEDANCE:	8 ohm
SYSTEM INPUT POWER RATING RMS:	600 W ⁽²⁾
SYSTEM INPUT POWER RATING PEAK:	2400 W
RECOMMENDED AMPLIFIER:	1200 W ⁽³⁾
HF PROTECTION:	Dynamic
CROSSOVER:	1.1 kHz

TRANSDUCERS

LOW FREQUENCY:	15" neo (380 mm) woofer with 3" (75 mm) voice coil
NOMINAL IMPEDANCE:	8 ohm
INPUT POWER RATING:	450 W AES; 900 W Peak
SENSITIVITY:	101 dB, 1W @ 1m
HIGH FREQUENCY:	1.3" neo (33 mm) throat, 2.5" (64 mm) voice coil
NOMINAL IMPEDANCE:	8 ohm
INPUT POWER RATING:	90 W AES; 180 W Peak
SENSITIVITY:	108 dB, 1W @ 1m

PHYSICAL

ENCLOSURE:	Trapezoidal, 10° Horizontal side angles, 20° Vertical side angle, 8 mm Polyethylene rotomoulded
RIGGING INSERTS:	12 x M10 + U-brackets and pair of spacers
COLOR:	Grey
GRILLE:	Custom perforated aluminium grille with open-cell fiber and water repellent woven fabric backing
INPUT CONNECTORS:	2 x 2.5mm square, 5m Neoprene cable
DIMENSIONS (H x W x D):	18.23" x 18.23" x 17.05" 463 x 463 x 433 mm
WEIGHT:	37.48 lb 17 kg

RESPONSE 1W/1m

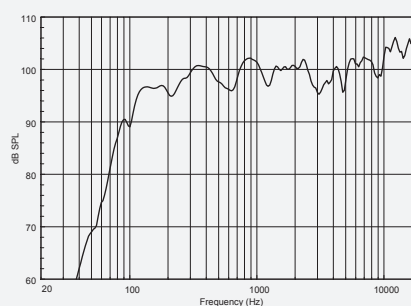

IMPEDANCE

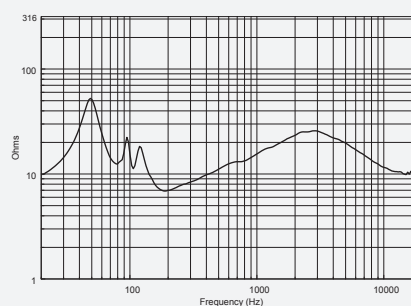

BEAMWIDTH vs. FREQUENCY

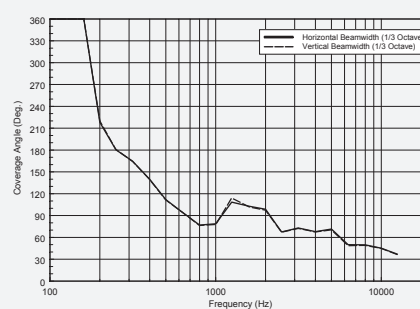

DIRECTIVITY INDEX AND Q

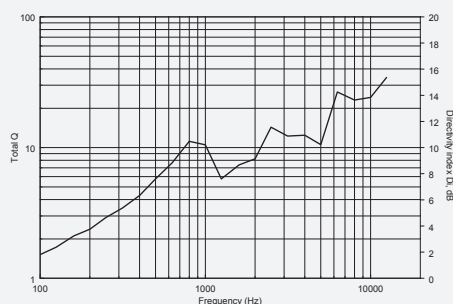

1) Measured on axis in the far field with 1 watt (2.83V RMS, 8 ohm) input and referenced to 1 meter distance using the inverse square law. Listed sound pressure represents an average from 300 Hz to 3 kHz.

2) Using 20 Hz to 20 kHz, Pink Noise Spectrum, 2 hours, + 6 dB crest factor, with RMS voltage calculated on speaker minimum impedance.

3) Recommended Amplifier is a power capability value that should be taken as a guide.

3115

P SERIES

P 3115T

OUTDOOR/INDOOR TWO-WAY COAXIAL SPEAKER SYSTEM

The P 3115T is a weatherproof full range, wide-dispersion, coaxial two-way loudspeaker system offering substantial power and efficiency for a variety of professional indoor or outdoor applications.

P 3115T high-frequency section is a constant directivity CMD horn loaded to a 1" RCF Precision Neodymium compression driver with a 1.5" diaphragm assembly for smooth, wide dispersion. The low-frequency transducer is a 15" woofer with a 2.5" voice coil. The P 3115T features a selectable line transformer for 70 - 100 Volt applications.

The cabinet is a single piece rotational moulded in medium density polyethylene, fully UV protected. The cabinet is equipped with 12 x M10 brass inserts, a stainless steel U-Bracket and pair of spacers for 90° mounting. The front logo is in aluminium and rotatable. The grille is in custom perforated aluminium with open-cell fibres and water repellent woven fabric backing. Both P 3115-T is suitable for indoor and outdoor applications/installations, they meet the requirements of IP 55 code (International Protection Rating).

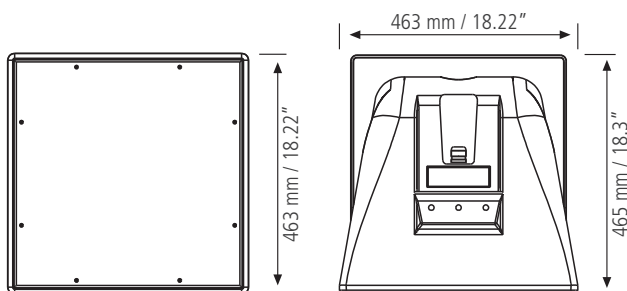

APPLICATIONS

- Outdoor Sound Reinforcement in medium and large spaces
- Very High-Level AV Playback
- Flown cluster configurations
- Large speech systems
- Music Sound Reinforcement



RELATED ACCESSORIES

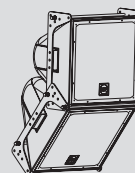

C-BR 2X P15

p.n. 133.60.094

Kit including 4 cluster brackets for P 3115-T (4 brackets cluster 2 speakers)

SUGGESTED PROCESSOR

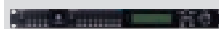

DX 4008

p.n. 121.35.033

4 inputs, 8 output digital processor



- Weatherproof cabinet IP 55
- Aluminium grill and stainless steel bracket
- One 15" high-output LF transducer with 2.5" voice coil
- One RCF Precision 1" C. Driver with 1.5" voice coil
- 90° x 60° constant directivity horn
- 10° X 20° enclosure sides for array configurations
- Active Mosfet Compression Driver Protection
- Equipped with a selectable line transformer



SPECIFICATIONS

P 3115T

p.n. 130.00.135

ACOUSTICAL

FREQ. RANGE (-10 dB):	75 Hz ÷ 20 kHz
FREQ. RANGE (-3 dB):	100 Hz ÷ 20 kHz
HORIZ. COVERAGE ANGLE (-6 dB):	90°
VERTICAL COVERAGE ANGLE (-6 dB):	60°
DIRECTIVITY FACTOR Q:	13.3
SYSTEM SENSITIVITY:	98 dB, 1W @ 1m ⁽¹⁾
RATED MAXIMUM SPL:	129 dB, @ 1m
SYSTEM NOMINAL IMPEDANCE:	16 ohm
SYSTEM INPUT POWER RATING RMS:	300 W ⁽²⁾
SYSTEM INPUT POWER RATING PEAK:	1200 W
RECOMMENDED AMPLIFIER:	600 W ⁽³⁾
CONSTANT VOLTAGE LINE:	70/100 V
SELECTABLE POWER:	70V/60W, 30W - 100V/120W, 60W
HF PROTECTION:	Dynamic
CROSSOVER:	1.3 kHz

TRANSDUCERS

LOW FREQUENCY:	15" neo (380 mm) woofer with 2.5" (63.5 mm) voice coil
NOMINAL IMPEDANCE:	16 ohm
INPUT POWER RATING:	250 W AES; 500 W Peak
SENSITIVITY:	98 dB, 1W @ 1m
HIGH FREQUENCY:	1" neo (25 mm) throat, 1.5" (38 mm) voice coil
NOMINAL IMPEDANCE:	8 ohm
INPUT POWER RATING:	25 W AES; 50 W Peak
SENSITIVITY:	108 dB, 1W @ 1m

PHYSICAL

ENCLOSURE:	Trapezoidal, 10° Horizontal side angles, 20° Vertical side angle, 8 mm Polyethylene rotomoulded
RIGGING INSERTS:	12 x M10 + U-brackets and pair of spacers
COLOR:	Grey
GRILLE:	Custom perforated aluminium grille with open-cell fiber and water repellent woven fabric backing
INPUT CONNECTORS:	4 x 1.5mm square, 5m Neoprene cable
DIMENSIONS (H x W x D):	18.23" x 18.23" x 17.05" 463 x 463 x 433 mm
WEIGHT:	40.57 lb 18.4 kg

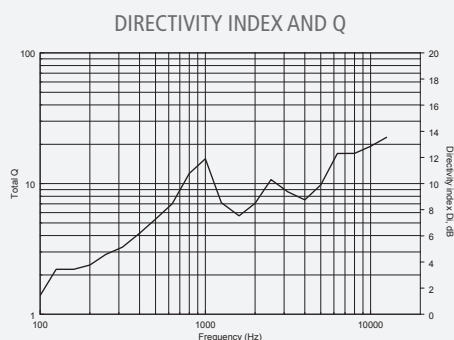
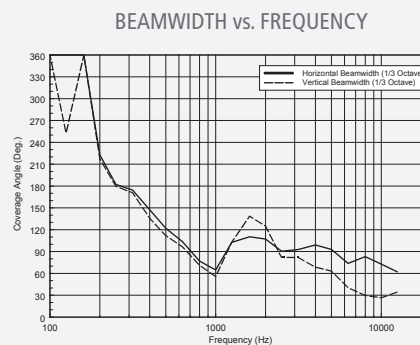
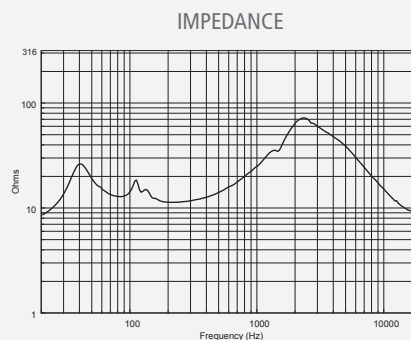
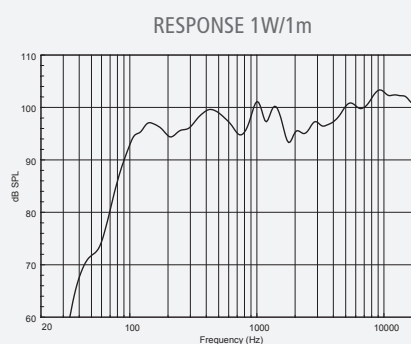

1) Measured on axis in the far field with 1 watt (2.83V RMS, 8 ohm) input and referenced to 1 meter distance using the inverse square law. Listed sound pressure represents an average from 300 Hz to 3 kHz.

2) Using 20 Hz to 20 kHz, Pink Noise Spectrum, 2 hours, + 6 dB crest factor, with RMS voltage calculated on speaker minimum impedance.

3) Recommended Amplifier is a power capability value that should be taken as a guide.

2110

P SERIES

P 2110T

OUTDOOR/INDOOR TWO-WAY COAXIAL SPEAKER SYSTEM

The P 2110T is a weatherproof full range, wide-dispersion, coaxial two-way loudspeaker system offering substantial power and efficiency for a variety of professional indoor or outdoor applications. The high-frequency section is a constant directivity CMD horn loaded to a 1" RCF Precision compression driver with a 1.50" diaphragm assembly for smooth, wide dispersion. The low-frequency transducer is a 10" woofer with a 2.5" voice coil.

The cabinet is a single piece rotational moulded in medium density polyethylene, fully UV protected. The cabinet is equipped with 12 x M8 brass inserts, a stainless steel U-Bracket and pair of spacers for 90° mounting. The front logo is in aluminium and rotatable.

The grille is in custom perforated aluminium with open-cell fibres and water repellent woven fabric backing. The system features a selectable line transformer for 70 - 100 Volt applications. P 2110-T is suitable for indoor and outdoor applications/installations, it meets the requirements of IP 55 code (International Protection Rating).

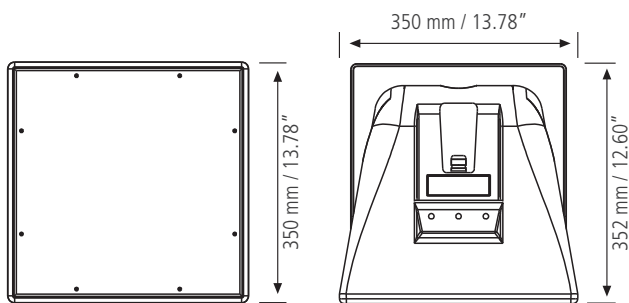

APPLICATIONS

- Outdoor Sound Reinforcement in small and medium spaces
- High-Level AV Playback
- Flown cluster configurations
- Large speech systems
- Music Sound Reinforcement



RELATED ACCESSORIES

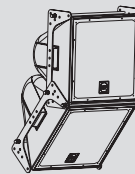

C-BR 2X P10

p.n. 133.60.095

Kit including 4 brackets to cluster 2 P 2110T speakers

SUGGESTED PROCESSOR



DX 4008

p.n. 121.35.033

4 inputs, 8 output digital processor



- Weatherproof cabinet IP 55
- Aluminium grill and stainless steel bracket
- One 10" high-output LF transducer with 2" voice coil
- One RCF Precision 1" Compression Driver with 1.5" voice coil
- 90° x 40° constant directivity horn
- Built in passive crossover and selectable line transformer
- 10° X 20° enclosure sides for array configurations
- Active Mosfet Compression Driver Protection
- LICC (Low Impedance Compensated Crossover) network



SPECIFICATIONS

P 2110T

p.n. 130.00.125

ACOUSTICAL

FREQ. RANGE (-10 dB):	95 Hz ÷ 20 kHz
FREQ. RANGE (-3 dB):	120 Hz ÷ 20 kHz
HORIZ. COVERAGE ANGLE (-6 dB):	90°
VERTICAL COVERAGE ANGLE (-6 dB):	40°
DIRECTIVITY FACTOR Q:	11
SYSTEM SENSITIVITY:	95 dB, 1W @ 1m ⁽¹⁾
RATED MAXIMUM SPL:	124 dB, @ 1m
SYSTEM NOMINAL IMPEDANCE:	16 ohm
SYSTEM INPUT POWER RATING RMS:	200 W ⁽²⁾
SYSTEM INPUT POWER RATING PEAK:	800 W
RECOMMENDED AMPLIFIER:	400 W ⁽³⁾
CONSTANT VOLTAGE LINE:	70/100 V
SELECTABLE POWER:	70V/30W, 15W - 100V/60W, 30W
HF PROTECTION:	Dynamic
CROSSOVER:	2 kHz

TRANSDUCERS

LOW FREQUENCY:	10" (254 mm) woofer with 2.5" (63.5 mm) voice coil
NOMINAL IMPEDANCE:	16 ohm
INPUT POWER RATING:	180 W AES; 720 W Peak
SENSITIVITY:	95 dB, 1W @ 1m
HIGH FREQUENCY:	1" (25 mm) throat, 1.5" (38 mm) voice coil
NOMINAL IMPEDANCE:	8 ohm
INPUT POWER RATING:	25 W AES; 100 W Peak
SENSITIVITY:	106 dB, 1W @ 1m

PHYSICAL

ENCLOSURE:	Trapezoidal, 10° Horizontal side angles, 20° Vertical side angle, 8 mm Polyethylene rotomoulded
RIGGING INSERTS:	12 x M8 + U-brackets and pair of spacers
COLOR:	Grey
GRILLE:	Custom perforated aluminium grille with open-cell fiber and water repellent woven fabric backing
INPUT CONNECTORS:	4 x 1.5mm square, 5m Neoprene cable
DIMENSIONS (H x W x D):	13.78" x 13.78" x 12.60" 350 x 350 x 320 mm
WEIGHT:	29.75 lb 13.5 kg

RESPONSE 1W/1m

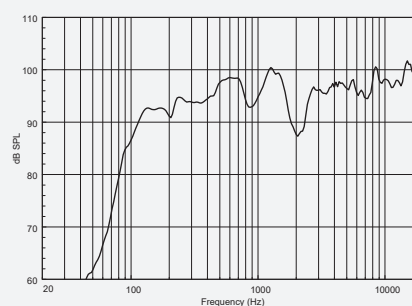

IMPEDANCE

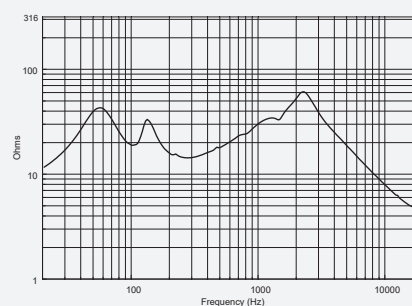

BEAMWIDTH vs. FREQUENCY

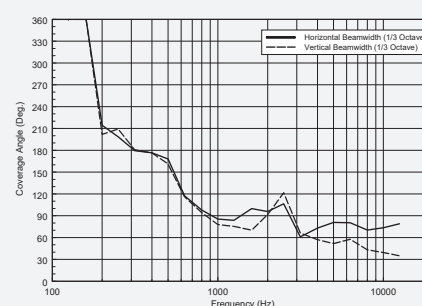

DIRECTIVITY INDEX AND Q

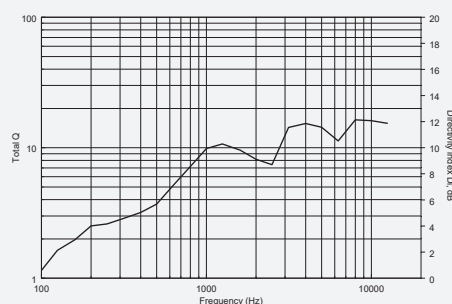

1) Measured on axis in the far field with 1 watt (2.83V RMS, 8 ohm) input and referenced to 1 meter distance using the inverse square law. Listed sound pressure represents an average from 300 Hz to 3 kHz.

2) Using 20 Hz to 20 kHz, Pink Noise Spectrum, 2 hours, + 6 dB crest factor, with RMS voltage calculated on speaker minimum impedance.

3) Recommended Amplifier is a power capability value that should be taken as a guide.

P SERIES

P 8015S

OUTDOOR/INDOOR SUBWOOFER

P 8015S is a weatherproof bass reflex subwoofer equipped with a 15" low frequency neodymium transducer with 4" voice coil offering enough power and efficiency for a variety of professional outdoor or indoor applications. The P 8015S has been specifically designed to reinforce sub bass frequencies in P Series speakers array systems.

The cabinet is a single piece rotational moulded in medium density polyethylene, fully UV protected. The cabinet is equipped with 12 x M10 brass inserts, a stainless steel U-Bracket and pair of spacers for 90° mounting. The front logo is in aluminium and rotatable. The grille is in custom perforated aluminium with open-cell fibres and water repellent woven fabric backing. The P 8015S is suitable for indoor and outdoor applications/installations, they meet the requirements of IP 55 code (International Protection Rating).

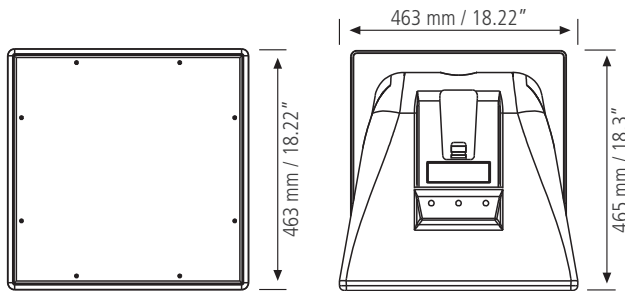

- Weatherproof cabinet IP 55
- Aluminium grill and stainless steel bracket
- Arrayable bass-reflex compact subwoofer
- 132 dB max SPL, 800 W AES
- 15" high power neodymium woofer with 4" voice coil



RELATED ACCESSORIES



C-BR 2X P15

p.n. 133.60.094

Kit including 4 cluster brackets for P 8015S
(4 brackets cluster 2 speakers)

SUGGESTED PROCESSOR

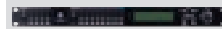

DX 4008

p.n. 121.35.033

4 inputs, 8 output digital processor





SPECIFICATIONS

P 8015S

p.n. 130.00.230

ACOUSTICAL

FREQ. RANGE (-10 dB):	50 Hz ÷ 200 Hz
SYSTEM SENSITIVITY:	97 dB, 1W @ 1m ⁽¹⁾
RATED MAXIMUM SPL:	132 dB, @ 1m
SYSTEM NOMINAL IMPEDANCE:	8 ohm
SYSTEM INPUT POWER RATING RMS:	800 W ⁽²⁾
SYSTEM INPUT POWER RATING PEAK:	3200 W
RECOMMENDED AMPLIFIER:	1600 W ⁽³⁾

TRANSDUCERS

LOW FREQUENCY:	15" (380 mm) woofer with 4" (100 mm) voice coil
NOMINAL IMPEDANCE:	8 ohm
INPUT POWER RATING:	900 W AES; 1800 W Peak
SENSITIVITY:	97 dB, 1W @ 1m

PHYSICAL

ENCLOSURE:	Trapezoidal, 10° Horizontal side angles, 20° Vertical side angle, 8 mm Polyethylene rotomoulded
RIGGING INSERTS:	12 x M10 + U-brackets and pair of spacers
COLOR:	Grey
GRILLE:	Custom perforated aluminium grille with open-cell fiber and water repellent woven fabric backing
INPUT CONNECTORS:	2 x 2.5mm square, 5m Neoprene cable
DIMENSIONS (H x W x D):	18.23" x 18.23" x 17.05" 463 x 463 x 433 mm
WEIGHT:	36.38 lb 16.5 kg

RESPONSE 1W/1m

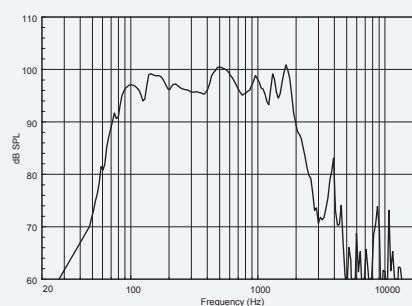

IMPEDANCE

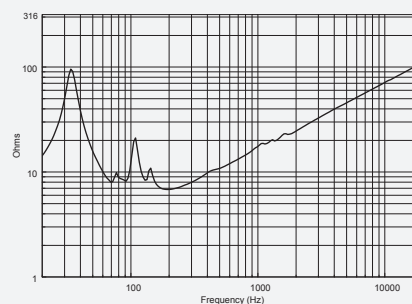

APPLICATIONS

- Outdoor sound reinforcement in medium and large spaces
- Very high level AV playback
- Flown clusters configurations
- Large speech systems
- Music sound reinforcement

1) Measured on axis in the far field with 1 watt (2.83V RMS, 8 ohm) input and referenced to 1 meter distance using the inverse square law. Listed sound pressure represents an average from 300 Hz to 3 kHz.

2) Using 20 Hz to 20 kHz, Pink Noise Spectrum, 2 hours, + 6 dB crest factor, with RMS voltage calculated on speaker minimum impedance.

3) Recommended Amplifier is a power capability value that should be taken as a guide.

725

ART SERIES

ART 725 MK4

PASSIVE TWO-WAY SPEAKER

The ART Series is the beating heart of RCF. These multiple purpose active speaker represent the finest examples of audio design in a rugged composite cabinet, now in offered black. The Mk4 Series is equipped with a new generation of high-powered woofers and the latest compression driver technology, plus a redesigned front grille, all in a black cabinet. The ART concept offers the best audio choice for many live sound applications.

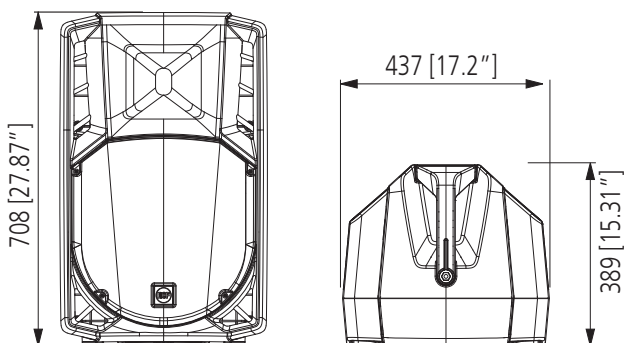

RELATED ACCESSORIES



H-BR 2X ART 715 p.n. 133.60.105

Horizontal bracket. Adjustable inclination.

/ 3.0" SUPERIOR COMPRESSION DRIVERS

The ART 725 is a unique speaker in its category. The titanium dome, 3.0" voice coil neodymium compression driver offers a unique vocal clarity and sound projection.



/ POWERFUL WOOFER

The 15" neodymium woofer offers an extremely linear response and a precise, deep low frequency control. The transducers are produced using the most advanced assembly technologies.

/ COMPONENT SAFETY

LICC (Low Impedance Compensated Crossover) with aluminium housed resistors and integrated heat sink to improve durability.

- 133 dB Max SPL
- 650 W AES power handling
- 1.4" Titanium C. Driver, 3.0" v.c. Neodymium
- 15" woofer, high power, 3.5" voice coil
- 1400 Hz crossover point for perfect vocal reproduction
- 90°x60°, wide dispersion constant directivity horn



SPECIFICATIONS

ART 725 MK4

p.n. 130.00.548

ACOUSTICAL

FREQ. RANGE (-10 dB):	55 Hz ÷ 20 kHz
HORIZ. COVERAGE ANGLE (-6 dB):	90°
VERTICAL COVERAGE ANGLE (-6 dB):	60°
DIRECTIVITY FACTOR Q:	11
SYSTEM SENSITIVITY:	99 dB, 1W @ 1m ⁽¹⁾
RATED MAXIMUM SPL:	133 dB, @ 1m
SYSTEM NOMINAL IMPEDANCE:	8 ohm
SYSTEM INPUT POWER RATING RMS:	650 W ⁽²⁾
SYSTEM INPUT POWER RATING PEAK:	1300 W
CROSSOVER:	1.4 kHz

TRANSDUCERS

LOW FREQUENCY:	15" (380 mm) woofer with 3.5" (90 mm) voice coil
NOMINAL IMPEDANCE:	8 ohm
INPUT POWER RATING:	650 W AES; 1300 W Peak
SENSITIVITY:	98 dB, 1W @ 1m
HIGH FREQUENCY:	1.4" (38 mm) throat, 3" (75 mm) voice coil
NOMINAL IMPEDANCE:	8 ohm
INPUT POWER RATING:	110 W AES; 220 W Peak
SENSITIVITY:	109 dB, 1W @ 1m

PHYSICAL

RIGGING INSERTS:	2 x M10
HANDLES:	1 Top, 2 Side
COLOR:	Black
GRILLE:	Steel
INPUT CONNECTORS:	Speakon
DIMENSIONS (H x W x D):	27.87" x 17.2" x 15.31" 708 x 437 x 389 mm
WEIGHT:	45.19 lb 20.5 kg

RESPONSE 1W/1m

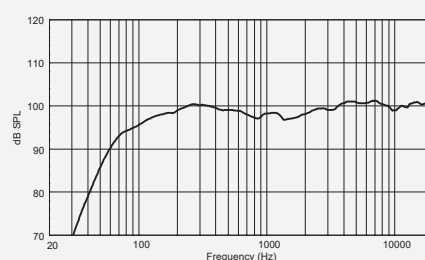

IMPEDANCE

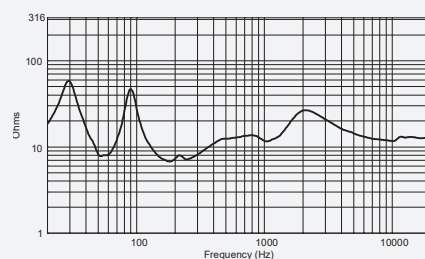

1) Measured on axis in the far field with 1 watt (2.83V RMS, 8 ohm) input and referenced to 1 meter distance using the inverse square law. Listed sound pressure represents an average from 300 Hz to 3 kHz.

2) Using 20 Hz to 20 kHz, Pink Noise Spectrum, 2 hours, + 6 dB crest factor, with RMS voltage calculated on speaker minimum impedance.

3) Recommended Amplifier is a power capability value that should be taken as a guide.

3 ART SERIES

ART 3 SERIES

MULTIPURPOSE TWO-WAY PASSIVE SPEAKERS

During the last fifteen years RCF transitioned into the forefront of passive and active loudspeaker technology, from the introduction of the original ART series to many prominent speaker systems conceived and designed in our laboratories. We have over the years grown to understand the best ways to use the extra degree of freedom that an injection moulded cabinet offers and in interpreting how such a cabinet and transducers interact each other.

The ART passive speakers have been designed for live sound reinforcement as well as distributed sound systems for clubs and music venues.

All models are equipped with extremely high quality RCF Precision compression drivers and high power woofers to offer unparalleled performance in both fixed installation and live situations.

APPLICATIONS

- Live music
- Clubs
- Fixed Installations
- Stage monitoring

RELATED ACCESSORIES



H-BR ART 310 p.n. 133.60.042

Pair of horizontal supports for ART 310.



V-BR ART 312 p.n. 133.60.010

Vertical bracket for mounting an ART speaker on the wall.



H-BR ART 312 p.n. 133.60.011

Horizontal bracket for mounting an ART speaker on the wall.

ART 315 MK4



ART 312 MK4



ART 310 MK4





SPECIFICATIONS

ART 315 MK4

p.n. 130.00.587

ART 312 MK4

p.n. 130.00.586

ART 310 MK4

p.n. 130.00.585

ACOUSTICAL

FREQ. RANGE (-10 dB):	50 Hz ÷ 20 kHz	50 Hz ÷ 20 kHz	50 Hz ÷ 20 kHz
HORIZ. COVERAGE ANGLE (-6 dB):	90°	90°	90°
VERTICAL COVERAGE ANGLE (-6 dB):	60°	60°	70°
SYSTEM SENSITIVITY:	99 dB, 1W @ 1m ⁽¹⁾	97 dB, 1W @ 1m ⁽¹⁾	97 dB, 1W @ 1m ⁽¹⁾
RATED MAXIMUM SPL:	128 dB, @ 1m	127 dB, @ 1m	127 dB, @ 1m
SYSTEM NOMINAL IMPEDANCE:	8 ohm	8 ohm	8 ohm
SYSTEM INPUT POWER RATING RMS:	300 W ⁽²⁾	300 W ⁽²⁾	300 W ⁽²⁾
SYSTEM INPUT POWER RATING PEAK:	1200 W	1200 W	1200 W
RECOMMENDED AMPLIFIER:	600 W ⁽³⁾	600 W ⁽³⁾	600 W ⁽³⁾
HF PROTECTION:	Electronic	Electronic	Electronic
CROSSOVER:	1.8 kHz	1.8 kHz	1.8 kHz

TRANSDUCERS

LOW FREQUENCY:	15" (380 mm) woofer 2.5" (64 mm) voice coil	12" (304 mm) woofer 2.5" (64 mm) voice coil	10" (254 mm) woofer 2" (51 mm) voice coil
NOMINAL IMPEDANCE:	8 ohm	8 ohm	8 ohm
INPUT POWER RATING:	300 W AES; 600 W Peak	300 W AES; 600 W Peak	250 W AES; 500 W Peak
SENSITIVITY:	100 dB, 1W @ 1m	98 dB, 1W @ 1m	96 dB, 1W @ 1m
HIGH FREQUENCY:	1" (25 mm) throat 1.5" (35.5 mm) voice coil	1" (25 mm) throat 1.5" (35.5 mm) voice coil	1" (25 mm) throat 1.5" (35.5 mm) voice coil
NOMINAL IMPEDANCE:	8 ohm	8 ohm	8 ohm
INPUT POWER RATING:	25 W AES; 50 W Peak	25 W AES; 50 W Peak	25 W AES; 50 W Peak
SENSITIVITY:	109 dB, 1W @ 1m	109 dB, 1W @ 1m	109 dB, 1W @ 1m

PHYSICAL

RIGGING INSERTS:	4 x M10 Flying p.	4 x M10 Flying p.	2 x M10 Flying p.
HANDLES:	2 side, 1 Top	2 side, 1 Top	1 Top
COLOR:	Black	Black	Black
INPUT CONNECTORS:	2 NL4 Speakon	2 NL4 Speakon	2 NL4 Speakon
DIMENSIONS (H x W x D):	26.77" x 15.94" x 13.58" 680 x 405 x 345 mm	26.77" x 15.94" x 13.58" 680 x 405 x 345 mm	21.14" x 13.27" x 12.36" 537 x 337 x 314 mm
WEIGHT:	37.48 lb 17 kg	35.27 lb 16 kg	28.66 lb 13 kg

¹⁾ Measured on axis in the far field with 1 watt (2.83V RMS, 8 ohm) input and referenced to 1 meter distance using the inverse square law. Listed sound pressure represents an average from 300 Hz to 3 kHz.

²⁾ Using 20 Hz to 20 kHz, Pink Noise Spectrum, 2 hours, + 6 dB crest factor, with RMS voltage calculated on speaker minimum impedance.

³⁾ Recommended Amplifier is a power capability value that should be taken as a guide.

SUB SERIES

S 8028 II

BASS REFLEX SUBWOOFER

The S 8028 II is a very high-output, high power bass reflex subwoofer. The system is equipped with two advanced, hyperventated 18" RCF precision woofers mounted in a bass reflex configuration. The cabinet design is optimised to achieve tight and maximised output. Each 18" features massive vented magnets and 4" copper voice coil and represents the state of the art of RCF precision transducers technology.

The system is able to produce a Max SPL of 141 dB and handles 3000 Watts AES. The cabinet features two Neutrik Speakon™ connectors in a recessed input plate. A M20 pole mount adaptor is provided on the top of the cabinet.



/ 2 X 18" PROFESSIONAL WOOFER

- 4-inch, fiberglass inside/outside copper voice coil
- Dual Forced Hyperventing System
- Dual spider design with silicon based dampening control
- Triple-roll surround and corrugated straight cone geometry

- 2 x 18" high-efficiency 4.0" voice-coil woofer with Inside/Outside Coil Technology
- 141 dB maximum sound pressure level
- Response down to 30 Hz
- System Power rating 3000 W RMS
- M20 standard pole mount in top section of cabinet
- Baltic Birch cabinet painted with black, heavy duty, textured epoxy
- Recessed Speakon NL4 Input/Output
- Protective metal grille, polyester fabric coated
- Integrated recessed hand carry points

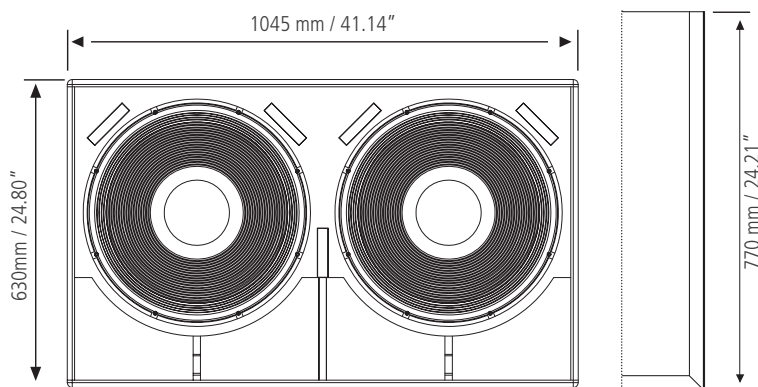



SPECIFICATIONS

S 8028 II

p.n. 130.00.391

ACOUSTICAL

FREQ. RANGE (-10 dB):	30 Hz ÷ 200 Hz
SYSTEM SENSITIVITY:	101 dB, 1W @ 1m ⁽¹⁾
RATED MAXIMUM SPL:	141 dB, @ 1m
SYSTEM NOMINAL IMPEDANCE:	4 ohm
SYSTEM INPUT POWER RATING RMS:	3000 W ⁽²⁾
SYSTEM INPUT POWER RATING PEAK:	12000 W
RECOMMENDED AMPLIFIER:	6000 W ⁽³⁾
RECOMMENDED CROSSOVER:	100 Hz

TRANSDUCERS

LOW FREQUENCY:	2 x 18" (457 mm) woofer with 4" (100 mm) voice coil
NOMINAL IMPEDANCE:	8 ohm
INPUT POWER RATING:	3000 W AES; 12000 W Peak
SENSITIVITY:	100 dB, 1W @ 1m

PHYSICAL

ENCLOSURE:	Rectangle, 15 mm Baltic birch plywood
RIGGING INSERTS:	M20, Recessed side handles
COLOR:	Black
GRILLE:	Custom perforated 2 mm steel grille
INPUT CONNECTORS:	Speakon® NL4
DIMENSIONS (H x W x D):	24.80" x 41.14" x 30.31" 630 x 1045 x 770 mm
WEIGHT:	176.37 lbs 80 kg

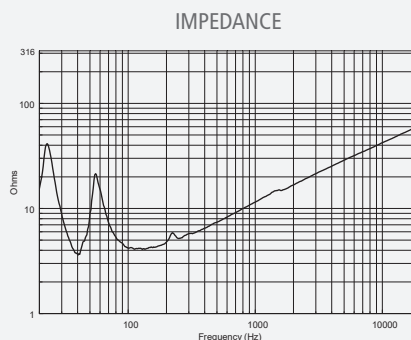
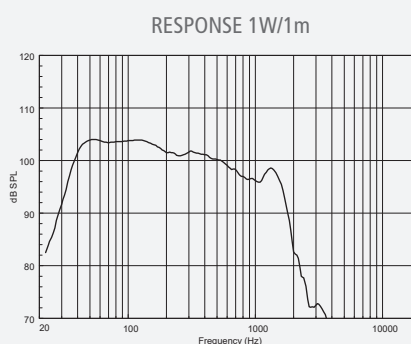

APPLICATIONS

- Low Frequency Enhancement
- Music Enhancement
- Special Effects Reinforcement
- Entertainment Systems
- Live Music Reinforcement
- Mid to Large Club Sound Systems
- Infill Sub Bass Enhancement



/ CONNECTORS

Connections are made through two Neutrik Speakon NL4 connectors (audio input and parallel link output).



/ HANDLES

2 on side

1) Measured on axis in the far field with 1 watt (2.83V RMS, 8 ohm) input and referenced to 1 meter distance using the inverse square law. Listed sound pressure represents an average from 300 Hz to 3 kHz.
 2) Using 20 Hz to 20 kHz, Pink Noise Spectrum, 2 hours, + 6 dB crest factor, with RMS voltage calculated on speaker minimum impedance.
 3) Recommended Amplifier is a power capability value that should be taken as a guide.

8018

SUB SERIES

S 8018 II

HIGH-EFFICIENCY SUBWOOFER

The S 8018 II high-efficiency subwoofer is the ideal low-frequency extension to complement RCF installed systems. The low-frequency transducer is a hypervented vented, high excursion RCF Precision 18" woofer with a 4" inside/outside voice coil to minimize power compression and extend the life of the product.

Using bass-reflex loading the subwoofer design ensures an efficient acoustic response down to 30 Hz. The Baltic birch plywood enclosure is painted with black, heavy duty, textured epoxy. The front is protected by a strong powder coated metal grille. The cabinet features two Neutrik Speakon™ connectors in a recessed input plate. A M20 pole mount adaptor is provided on the top of the cabinet, integrated hand carry points on the cabinet sides.



/ 1 X 18" PROFESSIONAL WOOFER

- 4-inch, fiberglass inside/outside copper voice coil
- Dual Forced Hyperventing System
- Dual spider design with silicon based dampening control
- Triple-roll surround and corrugated straight cone geometry

- 18" high-efficiency 4.0" voice-coil woofer with Inside/Outside Coil Technology
- 137 dB maximum sound pressure level
- Response down to 30 Hz
- System Power rating 1500 W RMS
- M20 standard pole mount in top section of cabinet
- Baltic Birch cabinet painted with black, heavy duty, textured epoxy
- Recessed Speakon NL4 Input/Output
- Protective metal grille, polyester fabric coated
- Integrated recessed hand carry points

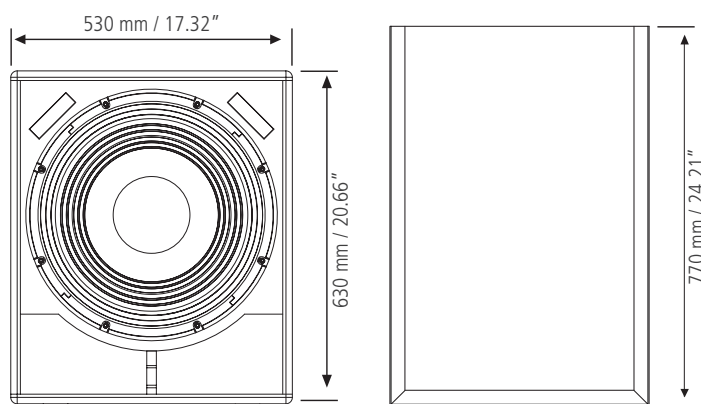



SPECIFICATIONS

S 8018 II

p.n. 130.00.390

ACOUSTICAL

FREQ. RANGE (-10 dB):	30 Hz ÷ 200 Hz
SYSTEM SENSITIVITY:	100 dB, 1W @ 1m ⁽¹⁾
RATED MAXIMUM SPL:	137 dB, @ 1m
SYSTEM NOMINAL IMPEDANCE:	8 ohm
SYSTEM INPUT POWER RATING RMS:	1500 W ⁽²⁾
SYSTEM INPUT POWER RATING PEAK:	6000 W
RECOMMENDED AMPLIFIER:	3000 W ⁽³⁾
RECOMMENDED CROSSOVER:	100 Hz

TRANSDUCERS

LOW FREQUENCY:	18" (457 mm) woofer with 4" (100 mm) voice coil
NOMINAL IMPEDANCE:	8 ohm
INPUT POWER RATING:	1500 W AES; 6000 W Peak
SENSITIVITY:	100 dB, 1W @ 1m

PHYSICAL

ENCLOSURE:	Rectangle, 15 mm Baltic birch plywood
RIGGING INSERTS:	M20
COLOR:	Black
GRILLE:	Custom perforated 2 mm steel grille
INPUT CONNECTORS:	Speakon® NL4
DIMENSIONS (H x W x D):	24.80" x 20.87" x 30.31" 630 x 530 x 770 mm
WEIGHT:	94.6 lbs 43 kg

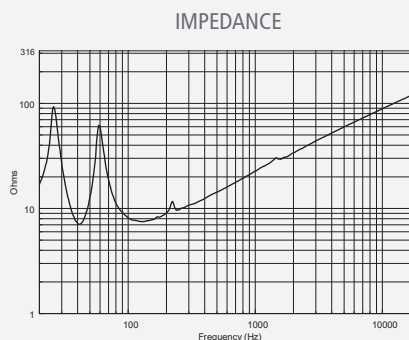

APPLICATIONS

- Low Frequency Enhancement
- Music Enhancement
- Special Effects Reinforcement
- Entertainment Systems
- Live Music Reinforcement
- Mid to Large Club Sound Systems



/ CONNECTORS

Connections are made through two Neutrik Speakon NL4 connectors (audio input and parallel link output).



/ HANDLES

2 on side

¹⁾ Measured on axis in the far field with 1 watt (2.83V RMS, 8 ohm) input and referenced to 1 meter distance using the inverse square law. Listed sound pressure represents an average from 300 Hz to 3 kHz.

²⁾ Using 20 Hz to 20 kHz, Pink Noise Spectrum, 2 hours, + 6 dB crest factor, with RMS voltage calculated on speaker minimum impedance.

³⁾ Recommended Amplifier is a power capability value that should be taken as a guide.

8015

SUB SERIES

S 8015 II

HIGH-EFFICIENCY SUBWOOFER

The S 8015 II is a compact, high-output, bass reflex subwoofer. The system is equipped with an advanced, hyperventated 15" RCF precision woofers. It features massive ceramic magnet and high excursion 4" copper voice coil. The cabinet is designed to achieve tight and maximised output.

The system is able to produce a Max SPL of 133 dB and handles 1000 Watts AES.

The loudspeaker enclosure shape is rectangular and the cabinet is constructed of multi-ply Baltic birch plywood and finished in a very resistant, textured, polyurethane black paint. It features a M20 pole-mount receptacle, rubber feet, 2 x recessed handles. The front steel grille is epoxy powder coated.



/ 1 X 15" PROFESSIONAL WOOFER

- 4-inch, fiberglass inside/outside copper voice coil
- Dual Forced Hyperventing System
- Dual spider design with silicon based dampening control
- Triple-roll surround and corrugated straight cone geometry

- 15" high-efficiency 4.0" voice-coil woofer with Inside/Outside Coil Technology
- 133 dB maximum sound pressure level
- Response down to 35 Hz
- System Power rating 1000 W RMS
- M20 standard pole mount in top section of cabinet
- Baltic Birch cabinet painted with black, heavy duty, textured epoxy
- Recessed Speakon NL4 Input/Output
- Protective metal grille, polyester fabric coated
- Integrated recessed hand carry points

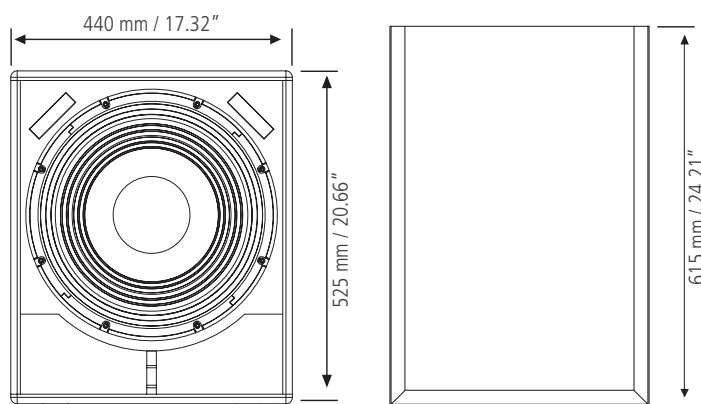



SPECIFICATIONS

S 8015 II

p.n. 130.00.398

ACOUSTICAL

FREQ. RANGE (-10 dB):	35 Hz ÷ 200 Hz
SYSTEM SENSITIVITY:	98 dB, 1W @ 1m ⁽¹⁾
RATED MAXIMUM SPL:	133 dB, @ 1m
SYSTEM NOMINAL IMPEDANCE:	8 ohm
SYSTEM INPUT POWER RATING RMS:	1000 W ⁽²⁾
SYSTEM INPUT POWER RATING PEAK:	4000 W
RECOMMENDED AMPLIFIER:	2000 W ⁽³⁾
RECOMMENDED CROSSOVER:	100 Hz

TRANSDUCERS

LOW FREQUENCY:	15" (381 mm) woofer with 4" (100 mm) voice coil
NOMINAL IMPEDANCE:	8 ohm
INPUT POWER RATING:	1000 W AES; 4000 W Peak
SENSITIVITY:	98 dB, 1W @ 1m

PHYSICAL

ENCLOSURE:	Rectangle, 15 mm Baltic birch plywood
RIGGING INSERTS:	M20
COLOR:	Black
GRILLE:	Custom perforated 2 mm steel grille
INPUT CONNECTORS:	Speakon® NL4
DIMENSIONS (H x W x D):	20.66" x 17.32" x 24.21" 525 x 440 x 615 mm
WEIGHT:	74.8 lbs 34 kg

RESPONSE 1W/1m

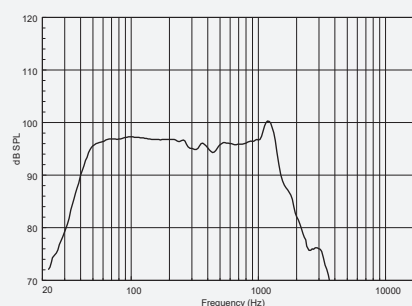

IMPEDANCE

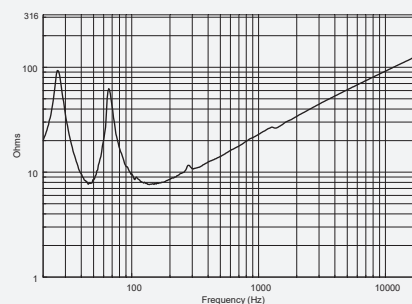

APPLICATIONS

- Low Frequency Enhancement
- Music Enhancement
- Special Effects Reinforcement
- Entertainment Systems
- Live Music Reinforcement
- Mid to Large Club Sound Systems



/ CONNECTORS

Connections are made through two Neutrik Speakon NL4 connectors (audio input and parallel link output).



/ HANDLES

2 on side

1) Measured on axis in the far field with 1 watt (2.83V RMS, 8 ohm) input and referenced to 1 meter distance using the inverse square law. Listed sound pressure represents an average from 300 Hz to 3 kHz.

2) Using 20 Hz to 20 kHz, Pink Noise Spectrum, 2 hours, + 6 dB crest factor, with RMS voltage calculated on speaker minimum impedance.

3) Recommended Amplifier is a power capability value that should be taken as a guide.

8015

SUB SERIES

S 8015LP

BASS REFLEX SUBWOOFER

The S 8015LP is an extremely compact, high output, band-pass subwoofer able to deliver tight and fast controlled bass response.

The new high power high sensitivity 15" woofer is the result of the latest RCF experience in sub-bass transducers and compact subwoofer design and manufacturing.

S 8015LP is a compact versatile high output sub-bass enclosure delivering extended low frequencies. The band-pass configuration offers a significant acoustic impact.

Resulting in a fast and controlled reproduction of the bass frequency range. Featuring a 4" inside/outside voice coil to minimize power compression, extending the life of the device. It is capable of a power of 1kW RMS and able to deliver a MAX SPL in excess of 135 dB.

The loudspeaker enclosure shape is unobtrusive rectangular low-profile to be used under-sofa or under limited height stages; the cabinet is constructed of multi-ply baltic birch plywood and finished in a very resistant, textured, black paint, rubber feet are also installed.

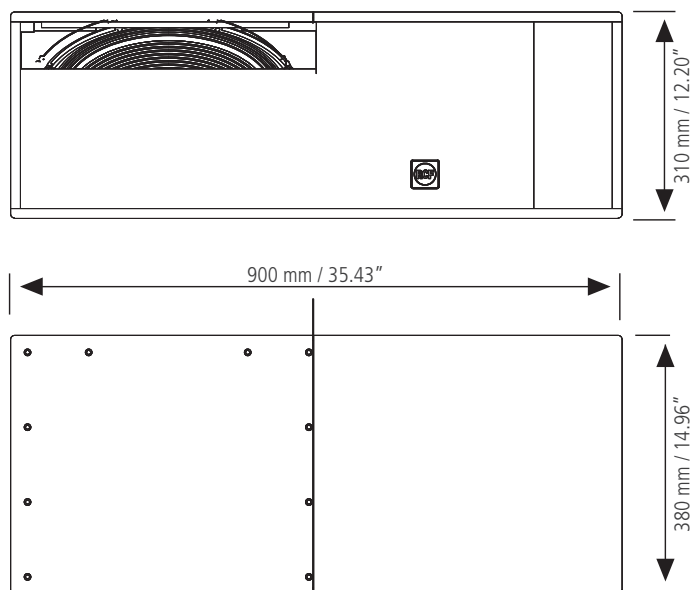

/ 1 X 15" PROFESSIONAL WOOFER

- 4-inch, fiberglass inside/outside copper voice coil
- Dual-forced air ventilation and 15mm top plate for minimum power compression
- Dual spider design with silicon based dampening control
- Triple-roll surround and corrugated straight cone geometry

- 15" high-efficiency RCF Precision 4" voice-coil woofer with Inside/Outside Coil Technology
- Bandpass woofer
- 135dB maximum sound pressure level
- Response down to 43 Hz
- Rectangular box enclosure





SPECIFICATIONS

S 8015LP

p.n. 130.00.168

ACOUSTICAL

FREQ. RANGE (-10 dB):	43 Hz ÷ 250 Hz
SYSTEM SENSITIVITY:	99 dB, 1W @ 1m ⁽¹⁾
RATED MAXIMUM SPL:	135 dB, @ 1m
SYSTEM NOMINAL IMPEDANCE:	8 ohm
SYSTEM INPUT POWER RATING RMS:	800 W ⁽²⁾
SYSTEM INPUT POWER RATING PEAK:	3200 W
RECOMMENDED AMPLIFIER:	1600 W ⁽²⁾
RECOMMENDED CROSSOVER:	160 Hz

TRANSDUCERS

LOW FREQUENCY:	neo 15" (381 mm) woofer with 4" (100 mm) in/out voice coil
NOMINAL IMPEDANCE:	8 ohm
PROGRAM POWER:	1800 W
POWER HANDLING CAPACITY:	900 W
SENSITIVITY:	97 dB, 1W @ 1m

PHYSICAL

ENCLOSURE:	Rectangle, 15 mm baltic birch plywood
RIGGING INSERTS:	Pole mount
COLOR:	Black
GRILLE:	Custom perforated steel grille
INPUT CONNECTORS:	Speakon® NL4
DIMENSIONS (H x W x D):	12.20" x 35.43" x 14.96" 310 x 900 x 380 mm
WEIGHT:	51.58 lb 23.4 kg

APPLICATIONS

- Low Frequency Enhancement
- Under-sofa and under-stage constraints
- Music Enhancement
- Club-Bar Bass Enhancement
- Special Effects Reinforcement
- Entertainment Systems
- Live Music Reinforcement
- Small and Mid Club Sound Systems
- Infill Sub Bass Enhancement
- Auditoriums
- AV presentations
- Retail stores

RESPONSE 1W/1m

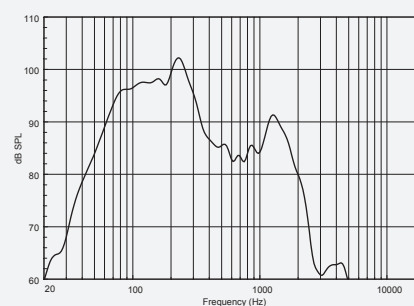

IMPEDANCE

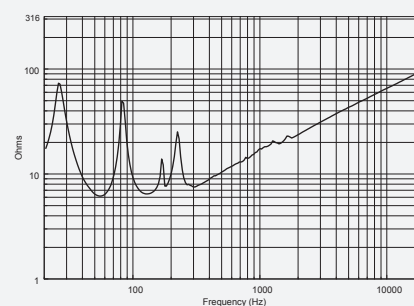

1) Measured on axis in the far field with 1 watt (2.83V RMS, 8 ohm) input and referenced to 1 meter distance using the inverse square law. Listed sound pressure represents an average from 300 Hz to 3 kHz.

2) Using 20 Hz to 20 kHz, Pink Noise Spectrum, 2 hours, + 6 dB crest factor, with RMS voltage calculated on speaker minimum impedance.

3) Recommended Amplifier is a power capability value that should be taken as a guide.

12 SUB SERIES

SUB S 12

BASS REFLEX SUBWOOFER

The S 12 is a high power, compact subwoofer system ideal for those installations where the physically small size and impact of a 12" driver are desired. Extending the frequency response of these systems to below 40Hz this highly efficient design is capable of providing output levels normally associated with considerably larger enclosures.

A system suited to background music playback in applications ranging from clubs, bars and cafes, right through to theatres and AV presentations. The low-frequency transducer is a 12" woofer with a 2,5" voice coil. Woofer design is the result of the latest refinements in RCF experiences in compact active and passive subwoofer design, resulting in a fast and controlled reproduction of the bass frequency range. It is particularly well-suited in high-quality multimedia applications.

POWERFUL LOWS

RCF subwoofers are the first choice of many sound engineers, due to their very high SPL levels at very low frequencies, smaller dimensions compared to the competitors, self-powered design, and impressive size/weight to SPL output ratio. Your audience will enjoy an engaging immersive musical experience.

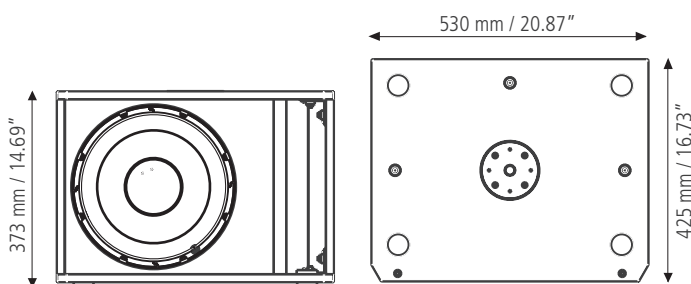

- 400W AES power handling
- 125 dB max SPL
- 40 ÷ 200 Hz frequency range
- 1 x 12" high power woofer
- High quality plywood cabinet
- M20 standard pole mount in top section of cabinet
- Steel front grille with clothing



RELATED ACCESSORIES

PNL IN-OUT SPEAKON COMPACT M p.n. 123.99.062



The EUROBLOCK connection panel can be replaced with female Neutrik SpeakON connection panel in seconds, thanks to the single connector on the back.

/ STATE OF THE ART TRANSDUCERS

The low-frequency transducers is a 12" woofer, with a 2,5" voice coil. Its design is the result of the latest refinements in RCF experiences in compact active and passive subwoofer design, resulting in a fast and controlled reproduction of the bass frequency range.



/ RIGGING INSERTS

Pole mount



SPECIFICATIONS

SUB S 12

p.n. 130.00.618

ACOUSTICAL

FREQ. RANGE (-10 dB):	40 Hz ÷ 200 Hz
SYSTEM SENSITIVITY:	93 dB, 1W @ 1m ⁽¹⁾
RATED MAXIMUM SPL:	125 dB, @ 1m
SYSTEM NOMINAL IMPEDANCE:	8 ohm
SYSTEM INPUT POWER RATING RMS:	400 W ⁽²⁾
SYSTEM INPUT POWER RATING PEAK:	1600 W
RECOMMENDED AMPLIFIER:	800 W ⁽³⁾

TRANSDUCERS

LOW FREQUENCY:	12" (304 mm) woofer with 2.5" (63.5 mm) voice coil
NOMINAL IMPEDANCE:	8 ohm
INPUT POWER RATING:	400 W AES, 800 W PEAK
SENSITIVITY:	93 dB, 1W @ 1m

PHYSICAL

ENCLOSURE:	Rectangle, 15 mm MDF
RIGGING INSERTS:	1 x M20, 10 x M10
COLOR:	Black
GRILLE:	Steel with clothing
INPUT CONNECTORS:	Euroblock
DIMENSIONS (H x W x D):	14.96" x 17.72" x 16.54" 373 x 530 x 425 mm
WEIGHT:	50.27 lbs 22.8 kg

APPLICATIONS

- Low Frequency Enhancement
- Live Music Sound Reinforcement
- Music Enhancement
- AV presentations
- Entertainment Systems

RESPONSE 1W/1m

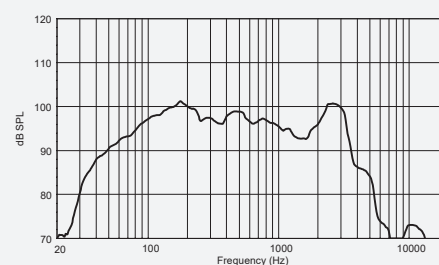

IMPEDANCE

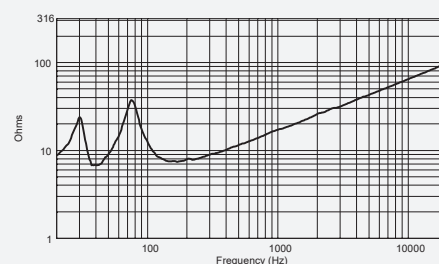

1) Measured on axis in the far field with 1 watt (2.83V RMS, 8 ohm) input and referenced to 1 meter distance using the inverse square law. Listed sound pressure represents an average from 300 Hz to 3 kHz.

2) Using 20 Hz to 20 kHz, Pink Noise Spectrum, 2 hours, + 6 dB crest factor, with RMS voltage calculated on speaker minimum impedance.

3) Recommended Amplifier is a power capability value that should be taken as a guide.

10

SUB SERIES

SUB S 10

BASS REFLEX SUBWOOFER

The S 10 is a high power, compact subwoofer system ideal for those installations where the physically small size and impact of a 10" driver are desired. Extending the frequency response of these systems to below 50Hz this highly efficient design is capable of providing output levels normally associated with considerably larger enclosures.

A system suited to background music playback in applications ranging from clubs, bars and cafes, right through to theatres and AV presentations. The low-frequency transducer is a 10" woofer with a 2,5" voice coil. Woofer design is the result of the latest refinements in RCF experiences in compact active and passive subwoofer design, resulting in a fast and controlled reproduction of the bass frequency range. It is particularly well-suited in high-quality multimedia applications.

POWERFUL LOWS

RCF subwoofers are the first choice of many sound engineers, due to their very high SPL levels at very low frequencies, smaller dimensions compared to the competitors, self-powered design, and impressive size/weight to SPL output ratio. Your audience will enjoy an engaging immersive musical experience.

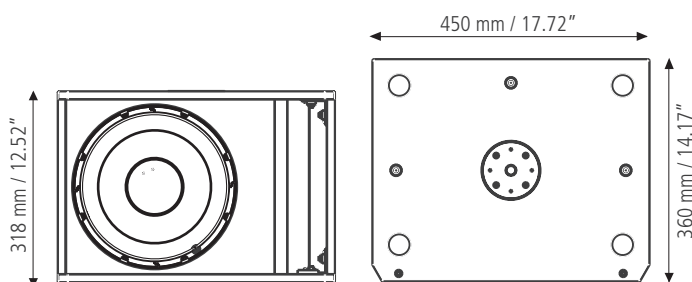

- 400W AES power handling
- 124 dB max SPL
- 50 ÷ 200 Hz frequency range
- 1 x 10" high power woofer
- High quality plywood cabinet
- M20 standard pole mount in top section of cabinet
- Steel front grille with clothing
- 4 pole EUROBLOCK connector (audio input and parallel link output)



RELATED ACCESSORIES

PNL IN-OUT SPEAKON COMPACT M p.n. 123.99.062



The EUROBLOCK connection panel can be replaced with female Neutrik SpeakON connection panel in seconds, thanks to the single connector on the back.

/ STATE OF THE ART TRANSDUCERS

The low-frequency transducers is a 10" woofer, with a 2,5" voice coil. Its design is the result of the latest refinements in RCF experiences in compact active and passive subwoofer design, resulting in a fast and controlled reproduction of the bass frequency range.



/ RIGGING INSERTS

Pole mount



SPECIFICATIONS

SUB S 10

p.n. 130.00.617

ACOUSTICAL

FREQ. RANGE (-10 dB):	50 Hz ÷ 200 Hz
SYSTEM SENSITIVITY:	92 dB, 1W @ 1m ⁽¹⁾
RATED MAXIMUM SPL:	124 dB, @ 1m
SYSTEM NOMINAL IMPEDANCE:	8 ohm
SYSTEM INPUT POWER RATING RMS:	400 W ⁽²⁾
SYSTEM INPUT POWER RATING PEAK:	1600 W
RECOMMENDED AMPLIFIER:	800 W ⁽³⁾

TRANSDUCERS

LOW FREQUENCY:	10" (254 mm) woofer with 2.5" (63.5 mm) voice coil
NOMINAL IMPEDANCE:	8 ohm
INPUT POWER RATING:	400 W AES, 800 W PEAK
SENSITIVITY:	92 dB, 1W @ 1m

PHYSICAL

ENCLOSURE:	Rectangle, 15 mm MDF
RIGGING INSERTS:	10 x M10
COLOR:	Black
GRILLE:	Steel with clothing
INPUT CONNECTORS:	Euroblock
DIMENSIONS (H x W x D):	12.52" x 17.72" x 14.17" 318 x 450 x 360 mm
WEIGHT:	41.23 lbs 18.7 kg

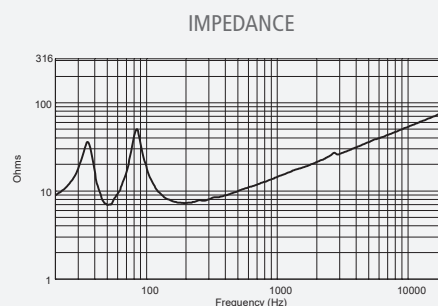
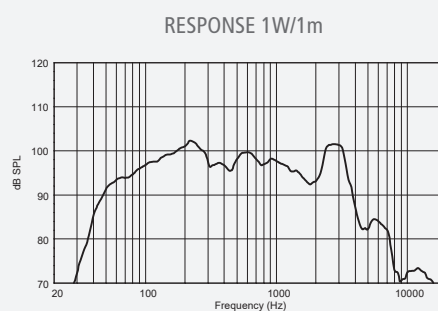

APPLICATIONS

- Low Frequency Enhancement
- Live Music Sound Reinforcement
- Music Enhancement
- AV presentations
- Entertainment Systems

1) Measured on axis in the far field with 1 watt (2.83V RMS, 8 ohm) input and referenced to 1 meter distance using the inverse square law. Listed sound pressure represents an average from 300 Hz to 3 kHz.

2) Using 20 Hz to 20 kHz, Pink Noise Spectrum, 2 hours, + 6 dB crest factor, with RMS voltage calculated on speaker minimum impedance.

3) Recommended Amplifier is a power capability value that should be taken as a guide.

4012

SUB SERIES

S 4012

BAND-PASS SUBWOOFER

The S 4012 high-efficiency Band-pass subwoofer is the ideal bass-frequency extension to complement the RCFACUSTICA Compact series two-way loudspeakers - C 3108 & C 3110 models.

This new woofer design is the result of the latest refinements in RCF experiences in compact active and passive subwoofer design, resulting in a fast and controlled reproduction of the bass frequency range. Using Band-pass loading to the transducer, the subwoofer design ensures an efficient acoustic response down to 45 Hz.

The Baltic birch plywood enclosure is painted with black, heavy duty, textured epoxy. The front is protected from a strong powder coated metal grille. The cabinet features two Neutrik Speakon™ connectors in a recessed input plate. A 35 mm pole mount adaptor is provided in the top of the cabinet, along with integrated hand carry points in the cabinet sides.

- 12" high-efficiency RCF Precision 3" voice-coil woofer with Inside/Outside Coil Technology
- Horn reflex loaded woofer
- 124dB maximum sound pressure level
- Response down to 45 Hz
- Rectangular box enclosure with protective metal grille
- 35 mm standard pole mount in top section of cabinet
- Integrated hand carry points



/ TRANSDUCERS

Is an RCF Precision high-power 12" woofer with a 3" inside/outside voice coil to minimize power compression and extend the life of the product.



/ CONNECTORS

Connections are made through two Neutrik Speakon NL4 connectors (audio input and parallel link output).

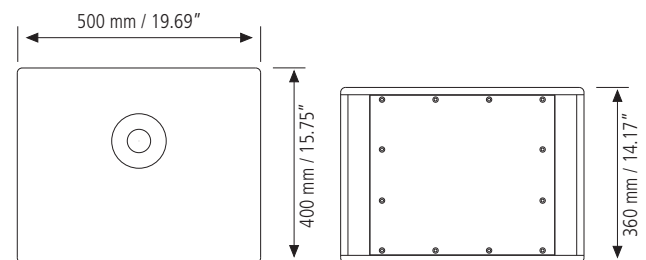



SPECIFICATIONS

S 4012

p.n. 130.00.048 (Black) - 130.00.115 (White)

ACOUSTICAL

FREQ. RANGE (-10 dB):	45 Hz ÷ 200 Hz
SYSTEM SENSITIVITY:	92 dB, 1W @ 1m ⁽¹⁾
RATED MAXIMUM SPL:	124 dB, @ 1m
SYSTEM NOMINAL IMPEDANCE:	8 ohm
SYSTEM INPUT POWER RATING RMS:	400 W ⁽²⁾
SYSTEM INPUT POWER RATING PEAK:	1200 W
RECOMMENDED AMPLIFIER:	800 W ⁽³⁾
RECOMMENDED CROSSOVER:	160 Hz

TRANSDUCERS

LOW FREQUENCY:	12" (304 mm) woofer with 3" (76 mm) in/out voice coil
NOMINAL IMPEDANCE:	8 ohm
PROGRAM POWER:	800 W
POWER HANDLING CAPACITY:	400 W
SENSITIVITY:	97 dB, 1W @ 1m

PHYSICAL

ENCLOSURE:	Rectangle, 15 mm birch plywood construction
RIGGING INSERTS:	Pole mount
COLOR:	Black, white, scratch resistant paint
GRILLE:	Custom perforated steel grille
INPUT CONNECTORS:	Speakon® NL4
DIMENSIONS (H x W x D):	14.17" x 19.69" x 15.75" 360 x 500 x 400 mm
WEIGHT:	46.3 lbs 21 kg

RESPONSE 1W/1m

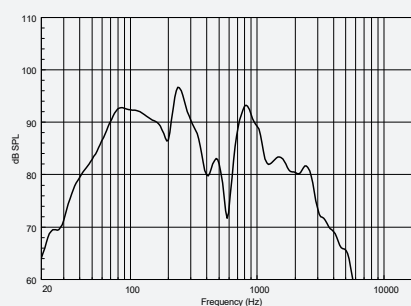

IMPEDANCE

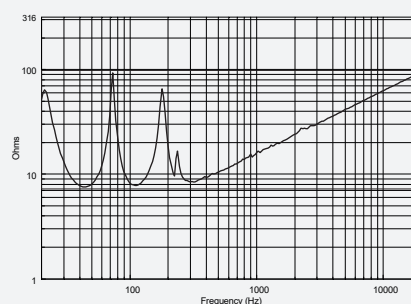

APPLICATIONS

- Low Frequency Enhancement
- Music Enhancement
- Special Effects Reinforcement
- Entertainment Systems
- Live Music Reinforcement
- Small Club Sound Systems
- Infill Sub Bass Enhancement



/ HANDLES
2 on side



/ RIGGING INSERTS
Pole mount

1) Measured on axis in the far field with 1 watt (2.83V RMS, 8 ohm) input and referenced to 1 meter distance using the inverse square law. Listed sound pressure represents an average from 300 Hz to 3 kHz.
2) Using 20 Hz to 20 kHz, Pink Noise Spectrum, 2 hours, + 6 dB crest factor, with RMS voltage calculated on speaker minimum impedance.
3) Recommended Amplifier is a power capability value that should be taken as a guide.

MR

MONITOR SERIES

MR 50T | MR 40T

TWO-WAY BASS REFLEX SPEAKER

MR series speakers are bass-reflex two-way speakers, equipped with 70/100 V line transformers, designed to deliver uncompromised audio performance with deep bass, smooth midrange, finely-detailed high-frequency response and high reliability in fixed installations. Quality components and careful acoustic design make MR series the perfect listening system in the most demanding applications, ideal for speech and music reproduction in business and A/V applications, bars and restaurants, hospitalities, recreational facilities, theme parks, shopping malls, and many others. The high-quality transducers, combined with RCF Low Inductance Compensated Crossover (LICC), assure exceptional audio performance and long-term reliability. Easy to blend with any décor and any architectural constrain, wall mounting supports are provided with each speaker, and a range of optional accessories increases the installation flexibility.

APPLICATIONS

- Music applications
- Audio visual applications
- Restaurants
- Places of worship
- Recreational facilities
- Shopping malls
- Pubs



MR 50T

- 60W AES power handling
- 110 dB max SPL
- 60 ÷ 20000 Hz frequency range
- 110° x 100° coverage angles
- 1 x 5" woofer (1" v.c.)
- 1 x 1" dome tweeter (0.8" v.c.)
- Body in self-extinguishing plastic
- Wall mount accessory included
- M6 inserts available for optional U bracket
- 4 pole EUROBLOCK connector (audio input and parallel link output)



MR 40T

- 40W AES power handling
- 108 dB max SPL
- 70 ÷ 20000 Hz frequency range
- 110° x 100° coverage angles
- 1 x 4" woofer (1" v.c.)
- 1 x 1" dome tweeter (0.8" v.c.)
- Body in self-extinguishing plastic
- Wall mount accessory included
- M6 inserts available for optional U bracket
- 4 pole EUROBLOCK connector (audio input and parallel link output)

RELATED ACCESSORIES

MA 4 - MA 4W



WALL MOUNT BRACKET
Bracket for mounting one MR 40T speaker on the wall

- MA 4 Black p.n. 133.60.367
- MA 4W White p.n. 133.60.368

MA 5 - MA 5W



WALL MOUNT BRACKET
Bracket for mounting one MR 50T series speaker on the wall

- MA 5 Black p.n. 133.60.369
- MA 5W White p.n. 133.60.370



SPECIFICATIONS

MR 50T

p.n. 131.00.039 (Black)
p.n. 131.00.041 (W: White)

MR 40T

p.n. 131.00.035 (Black)
p.n. 131.00.037 (W: White)

ACOUSTICAL

FREQ. RANGE (-10 dB):	60 Hz ÷ 20 kHz	70 Hz ÷ 20 kHz
HORIZ. COVERAGE ANGLE (-6 dB):	110°	110°
VERTICAL COVERAGE ANGLE (-6 dB):	100°	100°
SYSTEM SENSITIVITY:	87 dB, 1W @ 1m ⁽¹⁾	86 dB, 1W @ 1m ⁽¹⁾
RATED MAXIMUM SPL:	110 dB, @ 1m	108 dB, @ 1m
SYSTEM NOMINAL IMPEDANCE:	8 ohm	8 ohm
SYSTEM INPUT POWER RATING RMS:	60 W ⁽²⁾	40 W ⁽²⁾
SYSTEM INPUT POWER RATING PEAK:	240 W	160 W
RECOMMENDED AMPLIFIER:	120 W ⁽³⁾	80 W ⁽³⁾
PROTECTIONS:	Bulb Lamp	Bulb Lamp
CROSSOVER:	3 kHz	3 kHz
POWER SELECTION 1 (100 V):	40 - 20 - 10 - 5 W	20 - 10 - 5 - 2.5 W

TRANSDUCERS

LOW FREQUENCY:	5" (125 mm) woofer with 1" (25 mm) voice coil	4" (102 mm) woofer with 1" (25 mm) voice coil
HIGH FREQUENCY:	1" (25 mm) compression driver with 0.8" (20 mm) voice coil	1" (25 mm) compression driver with 0.8" (20 mm) voice coil

PHYSICAL

ENCLOSURE:	Self-extinguishing plastic	Self-extinguishing plastic
COLOR:	Black RAL 9005 White RAL 9003	Black RAL 9005 White RAL 9003
INPUT CONNECTORS:	Euroblock	Euroblock
DIMENSIONS (H x W x D):	10.63" x 7.36" x 6.85" 270 x 187 x 174 mm	8.5" x 6.06" x 5.31" 216 x 154 x 135 mm
WEIGHT:	7.5 lb 3.4 kg	3.74 lb 1.7 kg

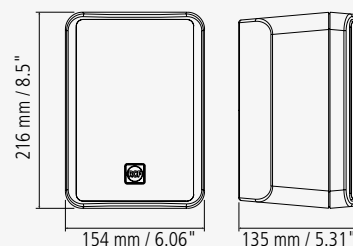
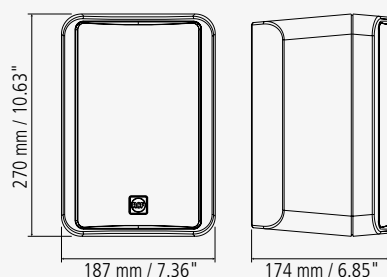

1) Measured on axis in the far field with 1 watt (2.83V RMS, 8 ohm) input and referenced to 1 meter distance using the inverse square law. Listed sound pressure represents an average from 300 Hz to 3 kHz.

2) Using 20 Hz to 20 kHz, Pink Noise Spectrum, 2 hours, + 6 dB crest factor, with RMS voltage calculated on speaker minimum impedance.

3) Recommended Amplifier is a power capability value that should be taken as a guide.

MF

EN 54-24 SPEAKERS

MF 33EN

TWO-WAY CEILING SPEAKER

MF 33EN is a two-way ceiling speaker designed for recess installation into ceilings or panels. It is especially suitable for broadcasting background music into commercial spaces, but also alarm messages thanks to the highly intelligible voice reproduction. It features a plastic cabinet with steel magnetic grille, extremely easy to install.

A thermal fuse protects the integrity of the line in case of heat affecting the speaker. The terminal connection blocks, for input and output flameproof cables, are made of ceramic material.

/ POWER SELECTOR

Easily accessible behind the magnetic grille



- 2 x 3" fullrange transducers with 1" dome tweeter
- Power selectable (100 V): 40 W - 20 W - 10 W - 5 W - 2.5 W
- 88 dB sensitivity
- Colour black RAL 9005
- Plastic body and steel grille
- In/out ceramic terminal block
- Thermal fuse protection

WMF 33EN

TWO-WAY WALL MOUNT SPEAKER

WMF 33EN is a two-way wall mount speaker designed for both horizontal and vertical installation. It is especially suitable for broadcasting background music into commercial spaces, but also alarm messages thanks to the highly intelligible voice reproduction. It features a plastic cabinet with steel magnetic grille, extremely easy to install thanks to the smart support.

/ TRANSDUCERS

2 x 3.0" fullrange, neo 1" dome tweeter



- 2 x 3" fullrange transducers with 1" dome tweeter
- Power selectable (100 V): 40 W - 20 W - 10 W - 5 W - 2.5 W
- 88 dB sensitivity
- Colour black RAL 9005
- Plastic body and steel grille
- In/out ceramic terminal block
- Thermal fuse protection
- Connections integrated in the wall support



SPECIFICATIONS

MF 33EN

p.n. 131.00.043

WMF 33EN

p.n. 131.00.046

ACOUSTICAL

FREQ. RANGE (-10 dB):	80 Hz ÷ 20 kHz	80 Hz ÷ 20 kHz
HORIZ. COVERAGE ANGLE (-6 dB):	100°	100°
VERTICAL COVERAGE ANGLE (-6 dB):	160°	160°
SYSTEM SENSITIVITY:	88 dB, 1W @ 1m ⁽¹⁾	88 dB, 1W @ 1m ⁽¹⁾
RATED MAXIMUM SPL:	104 dB, @ 1m	104 dB, @ 1m
SYSTEM NOMINAL IMPEDANCE:	8 ohm	8 ohm
SYSTEM INPUT POWER RATING RMS:	40 W ⁽²⁾	40 W ⁽²⁾
SYSTEM INPUT POWER RATING PEAK:	160 W	160 W
RECOMMENDED AMPLIFIER:	80 W ⁽³⁾	80 W ⁽³⁾
CROSSOVER:	2.5 kHz	2.5 kHz
PROTECTIONS:	Thermal fuse - PTC	Thermal fuse - PTC
POWER SELECTION 1 (100 V):	40 - 20 - 10 - 5 - 2.5 W	40 - 20 - 10 - 5 - 2.5 W

TRANSDUCERS

LOW FREQUENCY:	2 x 3" (76 mm) woofer with 1" (25 mm) voice coil	2 x 3" (76 mm) woofer with 1" (25 mm) voice coil
NOMINAL IMPEDANCE:	16 ohm	16 ohm
INPUT POWER RATING:	20 W AES, 40 W PEAK	20 W AES, 40 W PEAK
SENSITIVITY:	85 dB, 1W @ 1m	85 dB, 1W @ 1m
HIGH FREQUENCY:	neo 1" (25 mm) throat with 1" (25 mm) voice coil	neo 1" (25 mm) throat with 1" (25 mm) voice coil
NOMINAL IMPEDANCE:	8 ohm	8 ohm
INPUT POWER RATING:	15 W AES, 30 W PEAK	15 W AES, 30 W PEAK
SENSITIVITY:	90 dB, 1W @ 1m	90 dB, 1W @ 1m

PHYSICAL

ENCLOSURE:	ABS	ABS
GRILLE:	Steel	ABS
HARDWARE:	Ceiling mount brackets	Wall mount bracket
COLOR:	Black - RAL 9005	Black - RAL 9005
CPR NUMBER:	0068/CPR/057-2019	0068/CPR/057-2019
INPUT / OUTPUT CONNECTORS:	Ceramic screw terminals	Ceramic screw terminals
DIMENSIONS (H x W x D):	20.31" x 3.7" x 7.13" 516 x 94 x 181 mm	15.71" x 3.62" x 9.29" 399 x 92 x 236 mm
WEIGHT:	7.5 lb 3.4 kg	11.2 lb 5 kg

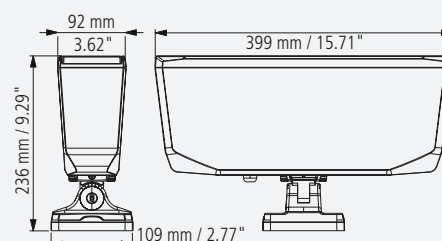
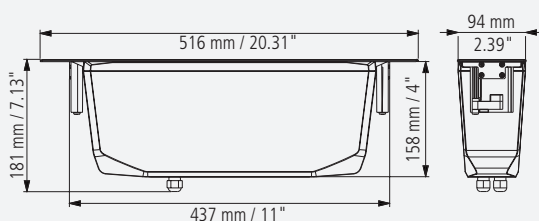

1) Measured on axis in the far field with 1 watt (2.83V RMS, 8 ohm) input and referenced to 1 meter distance using the inverse square law. Listed sound pressure represents an average from 300 Hz to 3 kHz.

2) Using 20 Hz to 20 kHz, Pink Noise Spectrum, 2 hours, + 6 dB crest factor, with RMS voltage calculated on speaker minimum impedance.

3) Recommended Amplifier is a power capability value that should be taken as a guide.

MQ

MONITOR Q SERIES

MQ 80P

TWO-WAY INDOOR OUTDOOR SPEAKER

High intelligibility, high efficiency and compact design make the RCF MQ80P 2-way horn-loaded sound projector speaker system the ideal solution to get clear voice and music reproduction in mid-size environment.

Suitable for PA systems and background/foreground music systems. Thanks to its 90° X 60° constant directivity and to simple accessories it can be combined in clusters of 2 or more pieces to get wide and smooth coverage and to reduce the installation points. It is suitable for both indoor and outdoor installations (IP 55). The woofer is a high-excursion, PP coated paper cone – rubber surround design mounted in a tuned enclosure (port can be sealed for full outdoor installation). The tweeter is a horn-loaded compression driver with phase plug, the only way to get real and crispy intelligible voice reproduction even in wide and noisy environments. Installation of the MQ80P is quick thanks to the unique bracket with several fixing points and aiming facilities. Connections are made by a multi-pole cable. Wattage taps and voltage adjustments together with 8-ohm operation are selectable by means of a Rotary switch, accessible under a sealed cover. The enclosure is constructed of high density UV resistant self-extinguishing polystyrene with robust steel grill.

- Speaker: woofer 5" horn-loaded, 1" horn-loaded compression driver with phase-plug loaded on CD horn
- Power/RMS: 120/60 W Bypass
- Tuning frequency: 100 Hz
- Crossover frequency: 3000 Hz Crossover: Notch/6 dB/oct
- IP 55, suitable for outdoor use
- Suitable for cluster installation (2x, 3x) for a wide and uniform coverage

MQ 60H

TWO-WAY INDOOR OUTDOOR SPEAKER

The MQ60H is a wall mount monitor speaker designed to guarantee uniform coverage of a large area in order to limit the number of speakers and therefore the installation points.

It is a two-way speaker with three transducers: the 5" woofer and the two horn-loaded dome tweeters with constant directivity are positioned in such a way as to ensure the maximum listening comfort within the area covered. Installation is carried out in two phases: first, you mount the support on the wall and make the electrical connections; when all the works are completed, you insert the speaker and make a quick connection.

RELATED ACCESSORIES

MQ 60H LINK

p.n. 133.60.367



MQ 60H LINK is available in black or white and can be used to support 2 MQ 60H speakers to form an omni directional high quality speaker array 360° dispersion over a horizontal surface which is controlled over a vertical surface.

- Two-way Bass reflex speaker for music reproduction
- Speaker composed by 5" woofer and 2 x 1" dome tweeter
- Max output power 120 W
- 2600 Hz crossover frequencies with attenuation 12/12 dB/oct
- Dynamic Protection on woofer and tweeter





SPECIFICATIONS

MQ 80P

p.n. 130.00.094 (-B: Black) - p.n. 130.00.096 (-W: White)

MQ 60H

p.n. 130.00.072 (-B: Black) - p.n. 130.00.060 (-W: White)

ACOUSTICAL

FREQ. RANGE (-10 dB):	100 Hz ÷ 20 kHz	100 Hz ÷ 19 kHz
HORIZ. COVERAGE ANGLE (-6 dB):	90°	180°
VERTICAL COVERAGE ANGLE (-6 dB):	60°	100°
SYSTEM SENSITIVITY:	94 dB, 1W @ 1m ⁽¹⁾	88 dB, 1W @ 1m ⁽¹⁾
RATED MAXIMUM SPL:	114 dB, @ 1m	109 dB, @ 1m
SYSTEM NOMINAL IMPEDANCE:	8 ohm	16 ohm
SYSTEM INPUT POWER RATING RMS:	60 W ⁽²⁾	60 W ⁽²⁾
SYSTEM INPUT POWER RATING PEAK:	240 W	240 W
RECOMMENDED AMPLIFIER:	120 W ⁽³⁾	120 W ⁽³⁾
CROSSOVER:	3 kHz	2 kHz
POWER:	30 - 20 - 10 - 5 W (100 V)	30 - 20 - 10 - 5 W (100 V)

TRANSDUCERS

LOW FREQUENCY:	5" (125 mm) woofer	5" (125 mm) woofer
HIGH FREQUENCY:	1" (25 mm) compression driver	2 x 1" (25 mm) compression driver

PHYSICAL

ENCLOSURE:	Self-extinguishing plastic	Self-extinguishing plastic
COLOR:	Black / White	Black / White
INPUT CONNECTORS:	-	Euroblock
DIMENSIONS (H x W x D):	8.77" x 7.51" x 9.29" 223 x 191 x 236 mm	11.69" x 7.8" x 4.8" 297 x 198 x 122 mm
WEIGHT:	6.61 lb 3 kg	6.28 lb 2.85 kg

APPLICATIONS

- Music applications
- Audio visual applications
- Restaurants
- Places of worship
- Recreational facilities
- Shopping malls
- Pubs

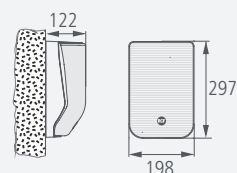
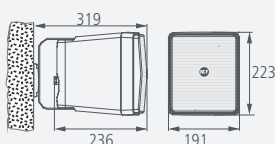

1) Measured on axis in the far field with 1 watt (2.83V RMS, 8 ohm) input and referenced to 1 meter distance using the inverse square law. Listed sound pressure represents an average from 300 Hz to 3 kHz.

2) Using 20 Hz to 20 kHz, Pink Noise Spectrum, 2 hours, + 6 dB crest factor, with RMS voltage calculated on speaker minimum impedance.

3) Recommended Amplifier is a power capability value that should be taken as a guide.

MQ

MONITOR Q SERIES

MQ 50

TWO-WAY COMPACT MONITOR

It is a two-way speaker with 5" woofer and waveguide-loaded dome tweeter to ensure intelligibility and correct dispersion of the sound over a wide angle of coverage.

The built-in support makes the MQ50 easy to install and enables close fitting to the wall, limiting its protrusion.

The exclusive attachment system designed for the MQ50 model allows the installer to fit the attachment bracket to the wall and make the electrical connections during the pre-installation phase; subsequently, when all the works are completed, the MQ50 is positioned, oriented, and connected with a simple "click", without the need for tools

- Two-way Bass reflex speaker for music reproduction
- Speaker: woofer 5" - tweeter 0,75" dome
- Crossover frequencies: 4500 Hz, 12/12 dB/oct
- Protection: Dynamic on woofer and tweeter
- Cabinet: Hi-density polystyrene HB grade
- Connectors: Euroblock, removable for easy installation

MQ 50i

TWO-WAY IN WALL SPEAKER

MQ 50i is a 2 way compact loudspeaker for indoor wall flush-mounting installation.

Its "bass-reflex" (/ vented) cabinet includes a 5" woofer and a waveguide loaded dome tweeter (to ensure a sound correct dispersion over a wide coverage angle).

It includes a transformer inside for the connection to (100 – 70 V) constant voltage lines, yet it can also be set to 16 Ω (low impedance connection).

The power / mode selection is made by means of the front panel rotary switch.

- In-wall speaker system for music reproduction
- Two-way bass refl ex construction for fl ush mount
- Speaker: woofer 5" neodymium magnet
0.75" dome tweeter
- Power: max. 60W (bypass)
- Crossover frequency: 3000 Hz, 12/12 dB/oct
- Cabinet: Plastic material self-extinguishing,
Tuned Alu-dome
- Connectors: Euroblock
- Suitable for standard Multibox enclosure, 2 modules





SPECIFICATIONS

MQ 50

p.n. 130.00.070 (-B: Black) - p.n. 130.00.056 (-W: White)

MQ 50i

p.n. 130.00.139

ACOUSTICAL

FREQ. RANGE (-10 dB):	70 Hz ÷ 20 kHz	180 Hz ÷ 20 kHz
HORIZ. COVERAGE ANGLE (-6 dB):	120°	120°
VERTICAL COVERAGE ANGLE (-6 dB):	100°	100°
SYSTEM SENSITIVITY:	89 dB, 1W @ 1m ⁽¹⁾	90 dB, 1W @ 1m ⁽¹⁾
RATED MAXIMUM SPL:	110 dB, @ 1m	108 dB, @ 1m
SYSTEM NOMINAL IMPEDANCE:	16 ohm	18 ohm
SYSTEM INPUT POWER RATING RMS:	60 W ⁽²⁾	60 W ⁽²⁾
SYSTEM INPUT POWER RATING PEAK:	240 W	240 W
RECOMMENDED AMPLIFIER:	120 W ⁽³⁾	120 W ⁽³⁾
CROSSOVER:	4.5 kHz	3 kHz
POWER:	30 - 20 - 10 - 5 W (100 V)	30 - 20 - 10 - 5 W (100 V)

TRANSDUCERS

LOW FREQUENCY:	5" (125 mm) woofer	5" (125 mm) woofer
HIGH FREQUENCY:	0,75" (19 mm) dome tweeter	0,75" (19 mm) dome tweeter

PHYSICAL

ENCLOSURE:	Self-extinguishing plastic	Self-extinguishing plastic
COLOR:	Black / White	White
INPUT CONNECTORS:	Euroblock	Euroblock
DIMENSIONS (H x W x D):	9.65" x 6.5" x 6.89" 245 x 165 x 175 mm	10.55" x 7.68" x 3.46" 268 x 195 x 88 mm
WEIGHT:	5.8 lb 2.63 kg	6.61 lb 3 kg

APPLICATIONS

- Music applications
- Audio visual applications
- Restaurants
- Places of worship
- Recreational facilities
- Shopping malls
- Pubs

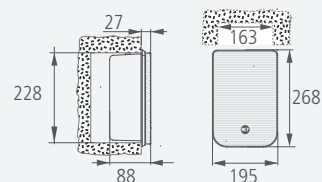
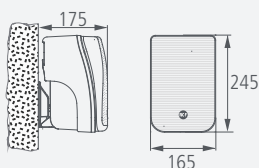

1) Measured on axis in the far field with 1 watt (2.83V RMS, 8 ohm) input and referenced to 1 meter distance using the inverse square law. Listed sound pressure represents an average from 300 Hz to 3 kHz.

2) Using 20 Hz to 20 kHz, Pink Noise Spectrum, 2 hours, + 6 dB crest factor, with RMS voltage calculated on speaker minimum impedance.

3) Recommended Amplifier is a power capability value that should be taken as a guide.

MQ

MONITOR Q SERIES

MQ 50C

TWO-WAY CEILING SPEAKER

Compact design, light weight and limited depth makes the RCF MQ50C 2-way ceiling monitor loudspeakers ideal for use in any PA systems and background/foreground music systems where the good sound is required.

The woofer is a high-excursion, PP coated paper cone – rubber surround design mounted in a tuned enclosure.

The fabric dome tweeter is loaded on a constant Q wave guide to provide natural, smooth sound reproduction on a wide dispersion angle. Installation of the MQ50C is fast and efficient using the built in rotating hooks.

No additional brackets or rings or other supports are required: thanks to its lightweight construction the speaker can be mounted as a conventional ceiling speakers. Connections are made to four polar loop thru Euroblock male and female to get parallel IN/OUT connection.

Wattage taps and voltage adjustments together with 16-ohm operation are selectable by means of a Rotary switch, accessible under the frontal grill.

The enclosure is constructed of high density UV resistant self-extinguishing polystyrene and includes a protective perforated steel grille. Back dome is made of aluminium.

- Two-way bass refl ex ceiling speaker for music reproduction
- Speaker: woofer 5" neodymium magnet tweeter 1" dome neodymium magnet
- Power/RMS: 120/60W Bypass
- Crossover frequencies: 3000 Hz, 12/12 dB/oct High pass fi lter at 150 Hz
- Angle of coverage: 120° horizontal x 120° vertical
- Cabinet: Plastic material self-extinguishing, Tuned Alu-dome

MQ 30P

MINIATURE TWO-WAY COAXIAL SPEAKER

The components are a 3" woofer and a coaxial dome tweeter that ensure a wide angle of coverage. The speaker faithfully reproduces announcements and provides a good music background where included.

Combined with a subwoofer, the MQ30P allows high quality music distribution with high output levels. An important feature of the MQ30P is that it provides consistent reproduction of all the frequencies involved in voice transmission and therefore, alone or in combination with a subwoofer, makes it possible to attain a high level of vocal intelligibility.

The MQ30P has been designed to adhere closely to the wall or ceiling and thus it has a limited protrusion.

The built-in hinged support makes the speaker easy to install and orient in any direction. Like the other Monitor Q products, MQ30P installation is simple and flexible. First, the support is mounted on the wall and the connector is wired; then, when the premises is completely furnished, the installation, orientation, and connection of the mini-speaker are immediate.

- Orientable mini-speaker fi r high quality reproduction
- Two-way coaxial speaker: LF 3,5" - tweeter 0,75" dome
- Power/RMS: 24/12 W Bypass
- Crossover frequencies: 5400 Hz, 6/6 dB/oct
- Built-in High-Pass fi lter at 150 Hz for integration with a subwoofer
- Cabinet: Hi-density polystyrene HB grade
- Connectors: Euroblock, removable for easy installation





SPECIFICATIONS

MQ 50C

p.n. 130.00.081

MQ 30P

p.n. 130.00.068 (-B: Black) - p.n. 130.00.058 (-W: White)

ACOUSTICAL

FREQ. RANGE (-10 dB):	70 Hz ÷ 20 kHz	150 Hz ÷ 20 kHz
HORIZ. COVERAGE ANGLE (-6 dB):	120°	120°
VERTICAL COVERAGE ANGLE (-6 dB):	120°	120°
SYSTEM SENSITIVITY:	91 dB, 1W @ 1m ⁽¹⁾	88 dB, 1W @ 1m ⁽¹⁾
RATED MAXIMUM SPL:	112 dB, @ 1m	102 dB, @ 1m
SYSTEM NOMINAL IMPEDANCE:	16 ohm	16 ohm
SYSTEM INPUT POWER RATING RMS:	30 W ⁽²⁾	12 W ⁽²⁾
SYSTEM INPUT POWER RATING PEAK:	120 W	48 W
RECOMMENDED AMPLIFIER:	60 W ⁽³⁾	24 W ⁽³⁾
CROSSOVER:	3 kHz	5.4 kHz
HF PROTECTION:	Dynamic	-
POWER:	30 - 20 - 10 - 5 W (100 V)	12 - 6 (100 V)

TRANSDUCERS

LOW FREQUENCY:	5" (125 mm) woofer	3.5" (90 mm) carbon fiber woofer
HIGH FREQUENCY:	1" (25 mm) dome tweeter	0,75" (19 mm) coaxial

PHYSICAL

ENCLOSURE:	Self-extinguishing plastic	Hi-density polystyrene HB grade
COLOR:	White	Black / White
INPUT CONNECTORS:	Euroblock	Euroblock
DIMENSIONS (H x W x D):	9.65" x 10.48" x 6.15" 245 x 266 x 156 mm	4.09" x 3.94" x 7.32" 104 x 100 x 186 mm
WEIGHT:	5.8 lb 2.1 kg	8.6 lb 1.2 kg

APPLICATIONS

- Music applications
- Audio visual applications
- Restaurants
- Places of worship
- Recreational facilities
- Shopping malls
- Pubs

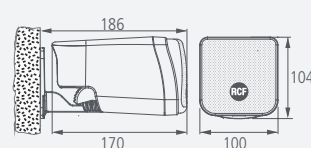
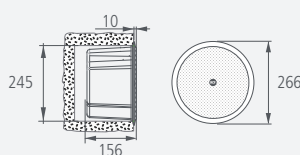

1) Measured on axis in the far field with 1 watt (2.83V RMS, 8 ohm) input and referenced to 1 meter distance using the inverse square law. Listed sound pressure represents an average from 300 Hz to 3 kHz.

2) Using 20 Hz to 20 kHz, Pink Noise Spectrum, 2 hours, + 6 dB crest factor, with RMS voltage calculated on speaker minimum impedance.

3) Recommended Amplifier is a power capability value that should be taken as a guide.

MQ

MONITOR Q SERIES

MQ 100L

THREE-WAY COLUMN LOUDSPEAKER

MQ 100L is a 3 way column array speaker system providing natural high intelligibility hi-fidelity sound for both speech and music, suitable for applications where the environment is acoustically critical or where architectural constraints require compact elements. The wide horizontal coverage angle (180°) and the 60° asymmetrical vertical dispersion allow the correct sound reproduction in a wide space, limit the downward tilting and helps reducing feedbacks and improving the sound directivity (important in halls having a long reverberation time). MQ 100L is equipped with: 2 rubber surround 3.5" woofers, 2 fabric surround 3.5" mid-woofers, 2 cloth coated 0.75" dome tweeters.

Mounting accessories are included. These have been studied to keep the column as close as possible to the wall and simplify its installation.

Even if the pre-oriented vertical acoustic axis allows to cover already the majority of the installations without requiring additional tilting, the MQ 100L is provided with accessories to physically orient the speaker down of extra 5° and 10°. Also on the horizontal plan the MQ 100L can be freely rotated for plus/minus several degrees.

- 2 rubber surround 3.5" woofers
- 2 fabric surround 3.5" mid-woofers
- 2 cloth coated 0.75" dome tweeters
- 118 dB (80 W/1 m) max. SPL
- Incl. 100V transformer multitap
- Power rotary switch
- Direct connection to Low-Z speaker lines
- Easy to install
- Simple power settings

MQ 90S

BAND PASS SUBWOOFER

MQ 90S is a compact band-pass 8" subwoofer.

It can be connected through a removable Euroblock plug that allows the parallel connection of other loudspeakers.

The cabinet material is MDF with a scratch resistant surface.

The subwoofer has internally a transformer for constant voltage lines (100 or 70 V). The power selection is made by means of its selector.

It is for indoor use only (avoid to use it in very humid places).

It should be put on the floor of a room where "satellite" loudspeakers (for mid / high frequencies) are already present. MQ 90S belongs to RCF Monitor Q series.

- SubWoofer 8", especially designed to be used with MonitorQ series speakers
- Well suitable also for other RCF speakers such as PL40, PL6X, DU 100X, DP 2X
- Power/RMS: 160/80W Bypass
- Crossover frequency: 200 Hz, 12 dB/oct
- As the subwoofer range is non-directional, the unit can be installed in a semi-hidden position
- Cabinet: material PVC covered Chipboard and Painted Front Medium density
- Input: Euroblock connector





SPECIFICATIONS

MQ 100L

p.n. 130.00.186 (Black) - p.n. 130.00.187 (-W: White)

MQ 90S

p.n. 130.00.097

ACOUSTICAL

FREQ. RANGE (-10 dB):	130 Hz ÷ 20 kHz	70 Hz ÷ 200 Hz
HORIZ. COVERAGE ANGLE (-6 dB):	180°	-
VERTICAL COVERAGE ANGLE (-6 dB):	60° (+20°, -40°)	-
SYSTEM SENSITIVITY:	93 dB, 1W @ 1m ⁽¹⁾	89 dB, 1W @ 1m ⁽¹⁾
RATED MAXIMUM SPL:	112 dB, @ 1m	107 dB, @ 1m
SYSTEM NOMINAL IMPEDANCE:	16 ohm	18 ohm
SYSTEM INPUT POWER RATING RMS:	80 W ⁽²⁾	60 W ⁽²⁾
SYSTEM INPUT POWER RATING PEAK:	320 W	240 W
RECOMMENDED AMPLIFIER:	160 W ⁽³⁾	120 W ⁽³⁾
CROSSOVER:	2 kHz	-
HF PROTECTION:	PTC	-
POWER:	40 - 20 - 10 - 5 W (100 V)	60 - 30 - 15 - 7.5 W (100 V)

TRANSDUCERS

LOW FREQUENCY:	4 x rubber surround 3.5" (89 mm) woofer	8" (203 mm) woofer
HIGH FREQUENCY:	2 cloth coated 0.75" (25 mm) dome tweeter	-

PHYSICAL

ENCLOSURE:	Self-extinguishing plastic	Self-extinguishing plastic
COLOR:	Black / White	Black
INPUT CONNECTORS:	Euroblock	4 x Euroblock
DIMENSIONS (H x W x D):	19.69" x 4.72" x 6.57" 500 x 120 x 167 mm	11.81" x 8.07" x 15.75" 300 x 205 x 400 mm
WEIGHT:	9.26 lb 4.2 kg	3.63 lb 8 kg

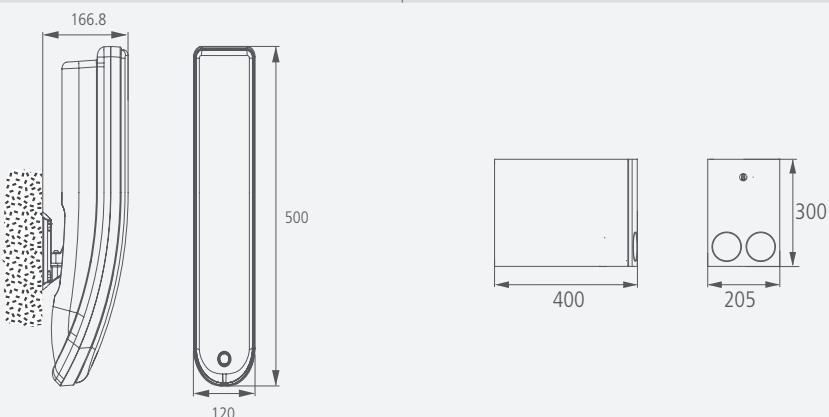

1) Measured on axis in the far field with 1 watt (2.83V RMS, 8 ohm) input and referenced to 1 meter distance using the inverse square law. Listed sound pressure represents an average from 300 Hz to 3 kHz.

2) Using 20 Hz to 20 kHz, Pink Noise Spectrum, 2 hours, + 6 dB crest factor, with RMS voltage calculated on speaker minimum impedance.

3) Recommended Amplifier is a power capability value that should be taken as a guide.

PRO AMPLIFIERS

QPS 9600

4 X 2400 HIGH POWER PRO AMPLIFIER

QPS 9600 is a 4 channel power amplifier that can handle exceptionally high power in a compact and lightweight 2 rack units space.

Thanks to the class HD technology, this amplifier delivers up to 4 x 2400 W RMS @ 2 ohm (4800 W RMS bridged @ 4 ohm), weighting just 16 kg.

It comes with switched mode power supply which ensures that a predominantly resistive load is presented to the mains power supply; this also leads to an improved amplifier performance at high output levels. Thanks to its high efficiency heat sinks and variable speed DC fans, the QPS 9600 can withstand the hardest heat conditions ensuring great reliability.

APPLICATIONS

- Small and medium sized PA systems
- Performance and sport venues
- Club sound
- DJs
- Worship systems
- Public spaces
- Cinema



- Fast response and low distortion
- Easy to configure in stereo / mono / bridge modes
- Extensive protective circuits ensure high reliability and operating safety
- Front panel signal / clippings / protection / temperature LEDs indicators
- Minimum load impedance (stereo / mono): 2 ohm
- XLR input connectors
- SPEAKON NL4 output connectors
- Voltage clip switchable limiters

HPS 2500

2 X 1100 POWER PRO AMPLIFIER

HPS 2500 is a 2 channel power amplifier that delivers up to 2 x 1100 W RMS @ 4 Ω (2200 W RMS bridged @ 8 Ω).

XLR inputs for patching in signals as well as Speakon ports for connecting speaker systems are provided for the maximum flexibility. A forced air cooling system maintains a low operating temperature.



- Fast response and low distortion
- Easy to configure in stereo / mono / bridge modes
- Extensive protective circuits ensure high reliability and operating safety
- Front panel signal / clip / protect LED indicators
- Minimum load impedance (stereo / mono): 4 ohm
- XLR input connectors
- SPEAKON output connectors
- Switchable limiter
- 2 unit 19" rack, low weight for easy transportation

HPS 1500

2 X 750 POWER PRO AMPLIFIER

HPS 1500 is a 2 channel power amplifier that delivers up to 2 x 750 W RMS @ 4 Ω (1500 W RMS bridged @ 8 Ω).

XLR inputs for patching in signals as well as Speakon ports for connecting speaker systems are provided for the maximum flexibility. A forced air cooling system maintains a low operating temperature.



APPLICATIONS

- Professional touring racks
- Installed Sound Systems



SPECIFICATIONS

	QPS 9600 p.n. 121.35.102 (230V) p.n. 121.35.103 (115V)	HPS 2500 p.n. 121.35.054	HPS 1500 p.n. 121.35.055
AMPLIFIER CLASS	HD	H	H
POWER OUTPUT RMS - STEREO	4 x 1300 W @ 8 Ω 4 x 2200 W @ 4 Ω 4 x 2400 W @ 2 Ω	2 x 1400 W @ 2 Ω 2 x 1100 W @ 4 Ω 2 x 700 W @ 8 Ω	2 x 750 W @ 4 Ω 2 x 450 W @ 8 Ω
POWER OUTPUT RMS - BRIDGED	2 x 4400 W @ 8 Ω 2 x 4800 W @ 4 Ω	2800 W @ 4 Ω 2200 W @ 8 Ω	1500 W @ 8 Ω
FREQUENCY RESPONSE	20 Hz ÷ 25 kHz	20 Hz ÷ 20 kHz	20 Hz ÷ 20 kHz
THD @ 1 KHZ	0.05 % (nominal power, 4 Ω)	0.05 % , 1 dB below clip	0.05 % , 1 dB below clip
SIGNAL / NOISE RATIO	110 dB	106 dB	106 dB
GAIN	23 – 44 dB (3 dB step)	26 – 32 dB	26 – 32 dB
INPUT IMPEDANCE	20 kΩ (bil.), 10 kΩ (unbal.)	20 kΩ (bil.), 10 kΩ (unbal.)	20 kΩ (bil), 10 kΩ (unbal.)
PROTECTIVE CIRCUITS	Temp., DC, RFI, short circuit	Temp., DC, RFI, short circuit	Temp., DC, RFI, short circuit
COOLING	Temperature-controlled fan	Temperature-controlled fan	Temperature-controlled fan
CROSSTALK (@ 1 KHZ)	> 70 dB	> 70 dB	> 70 dB
INPUT CONNECTORS	XLR female	XLR female	XLR female
POWER SUPPLY / OPERATION VOLTAGE	110 / 230 V, 50 / 60 Hz (depending on the model)	220 ÷ 240 V (50 / 60 Hz)	220 ÷ 240 V (50 / 60 Hz)
DIMENSIONS (W, H, D)	3.46" x 18.98" x 10.04" 88 x 482 x 255 mm	3.46" x 18.98" x 10.04" 88 x 482 x 255 mm	3.46" x 18.98" x 10.04" 88 x 482 x 255 mm
NET WEIGHT	35.27 lb 16 kg	41.89 lb 19 kg	37.47 lb 17 kg

PRO

PRO AMPLIFIERS

IPS 3700

2 X 1500W POWER PRO AMPLIFIER

IPS 3700 is a 2 channel power amplifier that offer exceptional sonic integrity in a compact and lightweight 2 rack units space.

This amplifier delivers up to 2 x 1500 W RMS @ 4 Ω (3000 W RMS bridged @ 8 Ω), weighing just 19,5 kg.

Thanks to its high efficiency class H design and high speed DC fans, the IPS 3700 can withstand the hardest heat conditions ensuring great reliability.

IPS 2700

2 X 1100W POWER PRO AMPLIFIER

IPS 2700 is a 2 channel power amplifier that offer exceptional sonic integrity in a compact and lightweight 2 rack units space.

This amplifier delivers up to 2 x 1100 W RMS @ 4 Ω (2200 W RMS bridged @ 8 Ω), weighing just 14,5 kg.

Thanks to its high efficiency class H design and high speed DC fans, the IPS 2700 can withstand the hardest heat conditions ensuring great reliability.

IPS 1700

2 X 450W POWER PRO AMPLIFIER

IPS 1700 is a 2 channel power amplifier that offer exceptional sonic integrity in a compact and lightweight 2 rack units space.

This amplifier delivers up to 2 x 450 W RMS @ 4 Ω (900 W RMS bridged @ 8 Ω), weighing just 12,7 kg.

Thanks to its high efficiency class H design and high speed DC fans, the IPS 1700 can withstand the hardest heat conditions ensuring great reliability.

IPS 700

2 X 300W POWER PRO AMPLIFIER

IPS 700 is a 2 channel power amplifier that offer exceptional sonic integrity in a compact and lightweight 2 rack units space.

This amplifier delivers up to 2 x 300 W RMS @ 4 Ω (600 W RMS bridged @ 8 Ω), weighing just 10,1 kg.

Thanks to its high efficiency heat sinks and high speed DC fans, the IPS 700 can withstand the hardest heat conditions ensuring great reliability.



- 2 unit 19" rack, easy transportation
- Fast response and low distortion
- Easy to configure in stereo / mono / bridge modes
- Extensive protective circuits ensure high reliability and operating safety
- Front panel signal / clip / protect LED indicators
- XLR input connectors
- SPEAKON NL4 output connectors

APPLICATIONS

- Small and medium sized PA systems
- Club sound
- DJs
- Performance and sport venues
- Worship systems
- Public spaces
- Cinema



SPECIFICATIONS

	IPS 3700 p.n. 121.35.093 (230V) p.n. 121.35.092 (115V)	IPS 2700 p.n. 121.35.091 (230V) p.n. 121.35.090 (115V)	IPS 1700 p.n. 121.35.089 (230V) p.n. 121.35.088 (115V)	IPS 700 p.n. 121.35.087 (230V) p.n. 121.35.086 (115V)
AMPLIFIER CLASS	H	H	H	AB
POWER OUTPUT (W) STEREO PER CHANNEL @ OHM	2 x 1500 W @ 4 Ω 2 x 1200 W @ 8 Ω	2 x 1100 W @ 4 Ω 2 x 700 W @ 8 Ω	2 x 450 W @ 4 Ω 2 x 350 W @ 8 Ω	2 x 300 W @ 4 Ω 2 x 150 W @ 8 Ω
BRIDGED POWER	3000 W @ 8 Ω	2200 W @ 8 Ω	900 W @ 8 Ω	600 W @ 8 Ω
FREQUENCY RESPONSE	20 Hz ÷ 20 kHz	20 Hz ÷ 20 kHz	20 Hz ÷ 20 kHz	20 Hz ÷ 20 kHz
THD @ 1 KHZ	< 1% (@ 1kHz)	< 1% (@ 1kHz)	< 1% (@ 1kHz)	< 0.5% (@ 1kHz)
SIGNAL / NOISE RATIO	> 100dB (@ 1kHz, 0dBu input)	> 100dB (@ 1kHz, 0dBu input)	> 100dB (@ 1kHz, 0dBu input)	> 100dB (@ 1kHz, 0dBu input)
IMPEDANCE	20 kΩ	20 kΩ	20 kΩ	20 kΩ
PROTECTIONS	DC, internal fault, input overload, RF interference, unmatched load, output short-circuit, thermal drift, power supply over-current			
COOLING	Internal heat sinks and forced ventilation			
CROSSTALK	> 75dB (@ 1kHz)	> 75dB (@ 1kHz)	> 75dB (@ 1kHz)	> 75dB (@ 1kHz)
INPUT CONNECTORS	XLR female	XLR female	XLR female	XLR female
POWER SUPPLY / OPERATION VOLTAGE	230V~ / 50-60 Hz	230V~ / 50-60 Hz	230V~ / 50-60 Hz	230V~ / 50-60 Hz
DIMENSIONS (H x W x D)	3.46" x 18.98" x 10.04" 88 x 482 x 255 mm	3.46" x 18.98" x 10.04" 88 x 482 x 255 mm	3.46" x 18.98" x 10.04" 88 x 482 x 255 mm	3.46" x 18.98" x 10.04" 88 x 482 x 255 mm
NET WEIGHT	36.6 lb 16.6 kg	26.9 lb 12.2 kg	24.69 lb 11.2 kg	20.95 lb 9.5 kg

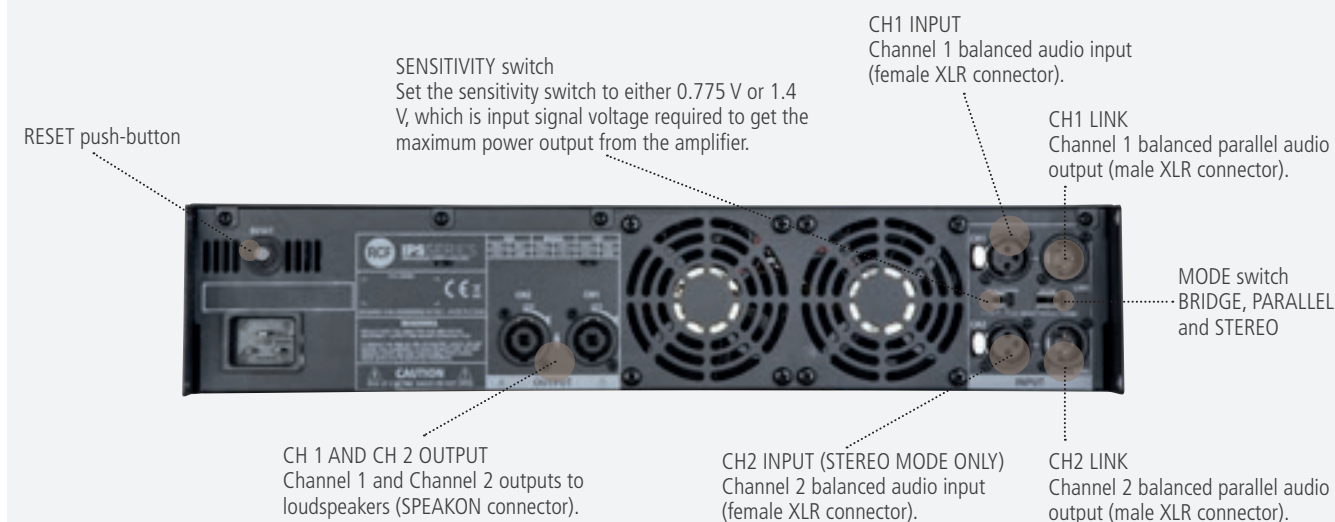

DMA

DIGITAL MIXER AMPLIFIERS

DMA

TWO CHANNEL DIGITAL MIXER AMPLIFIER

DMA series amplifiers are two channels class-D matrix amplifier equipped with a powerful DSP platform, allowing managing inputs and outputs in terms of routing and equalization: a complete set of processing functions is available, including RCF proprietary FIR filtering technology and bass enhancement algorithm. Dedicated presets for RCF speakers are also available, to optimize the global acoustic performance.

The DMA unit features extremely compact size and accurate design that, together with its robustness, makes it ideal for a wide range of business music applications, from retail stores to bars and restaurants, meeting rooms, education or public facilities, and generally to any A/V application. It offers user-friendly configuration through the front panel interface or via the RDNNet board (optional).



DMA 82

2 x 80 W RMS power handling (@ 4 ohm)

DMA 162

2 x 160 W RMS power handling (@ 4 ohm)

RELATED ACCESSORIES

RDNET BOARD DMA/DPA p.n. 123.99.048

RDNET BOARD is an additional board units that allows to connect your devices into an RDNNet network.

RM-KIT DMA-DPA p.n. 133.60.426

This accessory allows to install one or two DMA/DPA amplifier units inside 19" rack cabinets.

RC 401 EU B p.n. 123.99.051 (E.U.) black

RC 401 EU W p.n. 123.99.052 (E.U.) white

RC 401 US B p.n. 123.99.053 (E.U.) black

RC 401 US W p.n. 123.99.054 (E.U.) white

RC 401 is a wall mount remote that allows adjusting the output volume, mute or input program selection.

- Class-D amplifier unit
- 20 ÷ 20000 Hz frequency range
- Full on-board processing
- RCF speakers presets
- **FIRPHASE**
- Proprietary bass enhancer algorithm
- Flexible and scalable multi-room architecture
- Suitable for desk-top or rack installation
- RDNNet ready
- Remote controls and paging console accessories

REAR VIEW

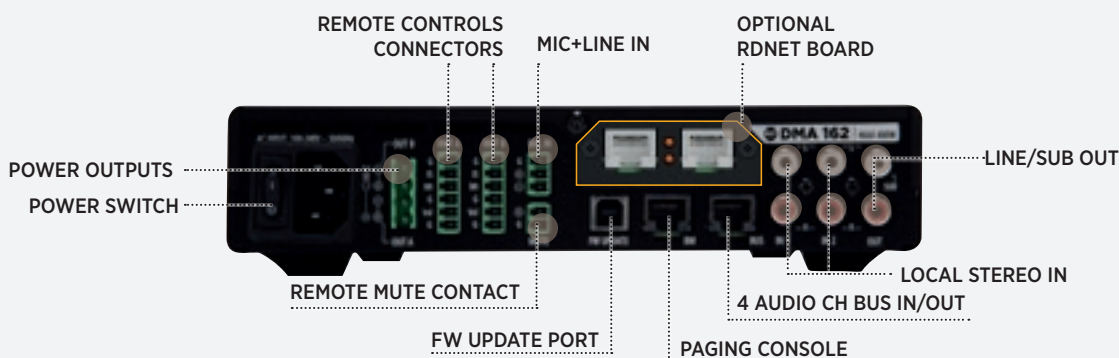

RC 401 EU



RC 401 US



SPECIFICATIONS

DMA 82

p.n. 121.00.026

DMA 162

p.n. 121.00.027

AMPLIFIER SPECIFICATIONS

POWER OUTPUT PER CHANNEL (@ 4 OHM):	80 W RMS	160 W RMS
POWER OUTPUT (BRIDGED @ 4 OHM):	160 W RMS	320 W RMS
POWER OUTPUT (@ 100 V):	160 W RMS	320 W RMS
FREQUENCY RESPONSE (-3DB):	20 Hz ÷ 20000 kHz	20 Hz ÷ 20000 kHz
SIGNAL/NOISE RATE ("A" WEIGHTED)	>93 dB dB	>93 dB dB
DISTORTION (THD+N) @ 1 KHZ NOMINAL POWER:	<0.01 %%	<0.01 %%
PROTECTIONS:	Cooling (Forced), Short circuit, Thermal, DC, Fuses, VHF (Very High Frequencies),	

INPUT / OUTPUT SECTION

TOTAL NUMBER OF INPUTS:	4	4
BALANCED:	2	2
UNBALANCED:	2	2
MONO:	2	2
STEREO:	2	2
VOX:	Yes	Yes
LINE INPUTS:	2	2
LINE CONNECTORS:	JACK, RCA	JACK, RCA
MIC+LINE INPUTS:	1	1
MIC+LINE CONNECTORS:	Euroblock	Euroblock
VOX:	Yes	Yes
PAGING INPUTS:	1	1
PAGING CONNECTORS:	RJ45	RJ45
PAGING COMMAND:	Contact	Contact
GENERAL PURPOSE INPUTS (GPI):	1	1
SIGNAL OUTPUT NUMBER:	1	1
SIGNAL OUTPUT CONNECTORS:	RCA	RCA
POWER OUTPUT CONNECTORS:	Euroblock	Euroblock

PROCESSING

PROCESSING:	DSP, EQ Filters, FIR, Compressors, Tone controls, High-pass filter,
HIGH-PASS FILTER:	80 ÷ 200 Hz

CONTROLS

CONFIGURATION:	Front panel, PC Software	Front panel, PC Software
----------------	--------------------------	--------------------------

GENERAL

OPERATING VOLTAGE:	90-240 V~ 50/60HzV ~ Hz	90-240 V~ 50/60HzV ~ Hz
POWER CONSUMPTION:	200 W	400 W
CABINET/CASE MATERIAL:	Metal	
COLOR:	Black	
RACK MOUNTING:	1/2 19", 1U , Optional rack mounting accessory required	
DIMENSIONS: H x W x D	1.73" x 8.39" x 12.36" (44 x 213 x 314 mm)	
WEIGHT:	6.61 lb - 3 kg	8.82 lb - 4 kg

DPA

DIGITAL POWER AMPLIFIERS

DPA

320W TWO CHANNELS POWER AMPLIFIER

DPA 162 is a two channels class-D power amplifier, equipped with on-board signal processing. Its natural use is in combination with a DPA unit, in order to increase Commercial Audio systems installed power and to implement multi-room architectures. However, its configurability, control tools and available inputs allow to use it as a stand alone amplifier.

DPA 162 features an extremely compact size and accurate design that, together with its environmental robustness, make it ideal for a wide range of business music applications, from retail stores to bars and restaurants, meeting rooms, education or public facilities, and more in general to any A/V application. It offers easy configuration through DIPSWITCH or (optional) RNet board.



DPA 162
320 W RMS power
handling (@ 4 ohm)

RELATED ACCESSORIES

RDNET BOARD DMA/DPA p.n. 123.99.048

RDNET BOARD is an additional board units that allows to connect your devices into an RNet network.

RM-KIT DMA-DPA p.n. 133.60.426

This accessory allows to install one or two DPA/DMA amplifier units inside 19" rack cabinets.

- 2 x 160W RMS power handling (@ 4 ohm)
- Class-D amplifier unit
- 20 ÷ 20000 Hz frequency range
- Full on-board processing
- RCF speakers presets and proprietary bass enhancer algorithm
- **FIRPHASE**
- Flexible and scalable multi-room architecture
- Remote MUTE command for the connection to Voice Alarm Systems
- Suitable for desk top or rack installation (optional accessory required)

REAR VIEW

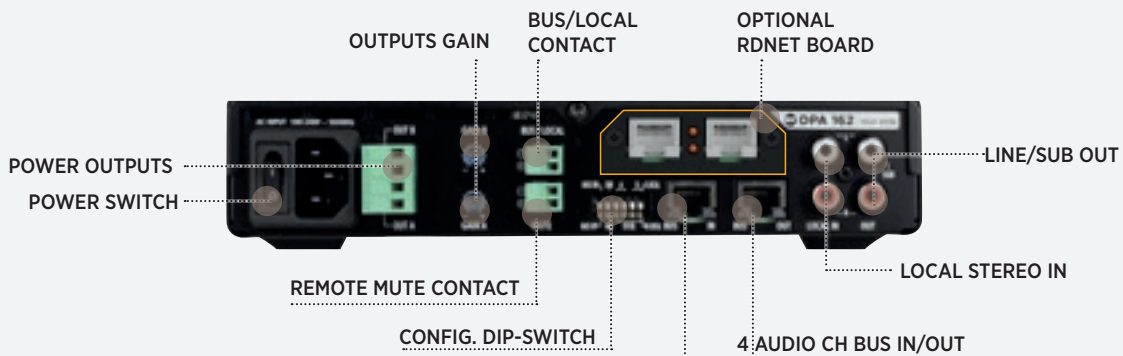



SPECIFICATIONS

DPA 162

p.n. 121.00.028

AMPLIFIER SPECIFICATIONS

POWER OUTPUT PER CHANNEL (@ 4 OHM):	160 W RMS
POWER OUTPUT (BRIDGED @ 4 OHM):	320 W RMS
POWER OUTPUT (@ 100 V):	320 W RMS
FREQUENCY RESPONSE (-3DB):	20 Hz ÷ 20000 kHz
SIGNAL/NOISE RATE ("A" WEIGHTED)	>93 dB dB
DISTORTION (THD+N) @ 1 KHZ NOMINAL POWER:	<0.01 %%
PROTECTIONS:	Cooling (Forced), Short circuit, Thermal, DC, Fuses, VHF (Very High Frequencies),

INPUT / OUTPUT SECTION

TOTAL NUMBER OF INPUTS:	5
BALANCED:	4
UNBALANCED:	1
MONO:	4
STEREO:	1
LINE INPUTS:	5
LINE CONNECTORS:	RCA, RJ45
GENERAL PURPOSE INPUTS (GPI):	2
SIGNAL OUTPUT NUMBER:	1
SIGNAL OUTPUT CONNECTORS:	RCA
POWER OUTPUT CONNECTORS:	Euroblock

PROCESSING

PROCESSING:	DSP, EQ Filters, FIR, Compressors, Tone controls, High-pass filter,
HIGH-PASS FILTER:	80 ÷ 200 Hz

CONTROLS

CONFIGURATION:	DIP switch, PC Software
----------------	-------------------------

GENERAL

OPERATING VOLTAGE:	90-240 V~ 50/60HzV ~ Hz
POWER CONSUMPTION:	400 W
CABINET/CASE MATERIAL:	Metal
COLOR:	Black
RACK MOUNTING:	1/2 19", 1U , Optional rack mounting accessory required
DIMENSIONS: H x W x D	1.73" x 8.39" x 12.36" (44 x 213 x 314 mm)
WEIGHT:	6.61 lb - 3 kg

604

DPS AMPLIFIER

DPS 604X

4 CHANNEL CLASS D POWER AMPLIFIER WITH CROSSOVER

DPS 604X is a 4-channel class D power amplifier designed for professional use in installed sound systems. It has 4 inputs and 4 outputs that could be combined in different configurations: a DIP switch on the rear panel allows to choose among 8 operational modes, and easily adapt the system to the specific installation. Moreover, it has two hi-pass filters (on channels A and B) and a low-pass filter for subwoofers, with cutoff frequencies in the range from 50 Hz to 250 Hz.

- Fast response and low distortion.
- Eight different operation modes, two of which with internal crossover.
- Extensive protective circuits ensure high reliability and operating safety.
- Level control for each channel on the front panel.
- Signal and peak LED for each channel.

/ OPERATIONAL MODES

Depending on the installation, the RCF DPS 604X can be configured in 8 different operational modes from the multiple DIP Switch on the back panel. Four independent channels linked directly to the four inputs are the standard functioning mode, but it is possible to select 7 different combinations with and without crossover, with linked, bridged channels and an active configurable crossover with 2 independent hi-pass filters and a single lowpass for the subwoofer.

APPLICATIONS

- Pubs
- Restaurants
- Shops
- Worship systems
- Small and medium sized PA systems





SPECIFICATIONS

DPS 604X

p.n. 121.00.008

RMS OUTPUT POWER (SINGLE CHANNELS)	4 x 80 W @ 8 Ω 4 x 150 W @ 4 Ω 4 x 230 W @ 2 Ω
RATED OUTPUT POWER (BRIDGED OUTPUTS)	2 x 300 W @ 8 Ω 2 x 400 W @ 4 Ω
FREQUENCY RESPONSE	20 Hz ÷ 14.1 kHz (+0/-3 dB) @ 2 Ω 20 Hz ÷ 24 kHz (+0.5/-3 dB) @ 4 Ω 20 Hz ÷ 33 kHz (+1.5/-3 dB) @ 8 Ω
TOTAL HARMONIC DISTORTION	0.1%
SIGNAL / NOISE RATIO	> 95 dB
AMPLIFIER VOLTAGE GAIN	28 ±0.5 dB
DAMPING FACTOR	> 200
CROSSTALK	< 70 dB
INPUT IMPEDANCE	20 kΩ (balanced), 10 kΩ (unbalanced)
INPUT SENSITIVITY	0.9-1.1 V (0±1dBV)
PROTECTIONS	Short circuit, open circuit, thermal drift, ultrasonic, RF protection, reactive or mismatched loads, internal fuses.
CONNECTORS	Euroblock
OPERATING VOLTAGE	115 / 230 V (according to the model), 50/60 Hz
DIMENSIONS (W x H x D)	483 x 44 x 281 mm (1U – 19" rack)
NET WEIGHT	4.5 kg

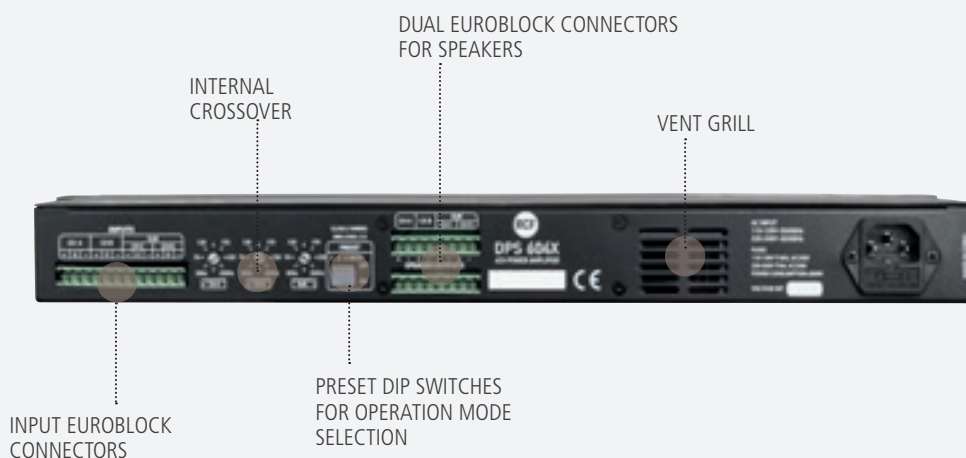

DX DIGITAL PROCESSOR

DX 1616

MATRIX AUDIO PROCESSOR

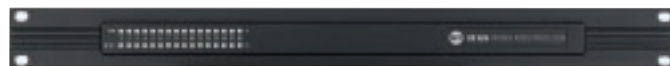

DX 1616 AES-Dante remote software. This network-based software designed for Microsoft Windows and Mac OSX allows the management of the DX 1616 Matrix Sound Processor. The DX 1616 matrix audio processor features Ethernet control, Dante redundant inputs, eight AES/EBU inputs and outputs. The signals are managed from a 40 bit floating point, high resolution DSP.

The home screen gives the most important information of the signal flow to the system engineer in one view. All inputs with pre-fade level meters including the routing to dedicated DSP modules for typical system tasks for main PA, side PA, subwoofer and distributed speakers. Useful groups of inputs allow easy setup and configuration for any large event application with several mixing desks or multiple sources.

The powerful source processing window allows the configuration of the input preamps (analog, AES/EBU, mic/line) and Dante inputs as well. For each source the user can adjust gain, polarity, input EQ, input compressor and input delay. Thanks to 16 analog outputs, DX 1616 offers flexible routing possibilities.

The engineer can use up to 16 individual DSP modules for each output or he can even assign several analog outputs to a specific DSP module to use these outputs as high quality line drivers. In combination with the RCF CP16 control panel any demand of wiring the audio system is supported.

DX 4008

4 INPUT - 8 OUTPUT DIGITAL PROCESSOR

he DX 4008 is a complete 4 input - 8 output digital loudspeaker management system designed for the touring or fixed sound installation markets.

The absolute latest in available technology is utilized with 32-bit (40-bit extended) floating point processor and high performance 24-bit Analog Converters. The high-bit DSP prevents noise and distortion induced by truncation errors of the commonly used 24-bit fixed-point devices. A complete set of parameters include I/O levels, delay, polarity, 6 bands of parametric EQ per channel, multiple crossover selections and full function limiters. The DX 4008 can be controlled or configured in real time on the panel or with the intuitive PC GUI accessed via the RS 232 interface. Software upgrade for CPU and DSP via PC keeps the device current with newly developed algorithms and function once available. Multiple setup storage and system security complete this professional package.

DX 2006

2 INPUT - 6 OUTPUT DIGITAL PROCESSOR

The DX 2006 is a 2 input - 6 output loudspeaker management device with 40 bit floating point DSP and 96 kHz sampling rate, suitable for the optimization of passive loudspeaker systems.

The DX 2006 offers flexible routing, signal processing and equalization and can be used also for multiple ways and multi-amplified systems managing. LCD, controls and LED indicators are available on the frontal panel and it is also possible to set up and control the processor through a PC. Various crossover modes are available and 30 programs/Settings can be stored.

The DX 2006 is shipped with a special PC Graphic User Interface (GUI) application - Xlink that gives the user an option to control the digital processor. The GUI application makes it much easier to control and monitor the device, allowing the user to get the whole picture on screen. Programs can be recalled and stored from/to PC hard drive, thus expanding the storage to become virtually limitless.

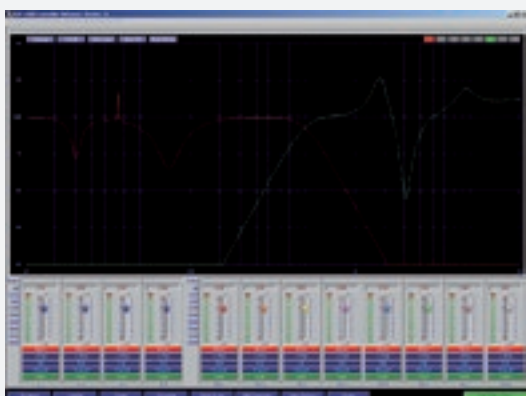
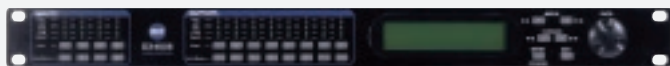

The DX 4008 and DX 2006 are shipped with a special PC Graphic User Interface (GUI) application – Xlink that gives the user an option to control the digital processors. The GUI application makes it much easier to control and monitor the devices, allowing the user to get the whole picture on one screen. Programs can be recalled and stored from/to PC hard drive, thus expanding the storage to become virtually limitless.



SPECIFICATIONS

DX 1616

p.n. 123.99.033

DX 4008

p.n. 121.35.033

DX 2006

p.n. 121.35.068

IN AND OUT

INPUT IMPEDANCE:	>10k ohm	>10k ohm	>10k ohm
OUTPUT IMPEDANCE:	< 120 ohm	50 ohm	50 ohm
MAXIMUM LEVEL:	=+20 dBu	=+20 dBu	=+20 dBu
TYPE:	Electronically balanced	Electronically balanced	Electronically balanced

AUDIO PERFORMANCE

FREQUENCY RESPONSE:	=+/- 0.1dB (20 to 30 kHz)	=+/- 0.1dB (20 to 30 kHz)	=+/- 0.1dB (20 to 30 kHz)
DYNAMIC RANGE:	110 dB typ (unweighted)	115 dB typ (unweighted)	115 dB typ (unweighted)
CMMR:	100 dB (50 to 10 kHz)	> 60 dB (50 to 10 kHz)	> 60 dB (50 to 10 kHz)
CROSSTALK:	< -100 dB	< -100 dB	< -100 dB
DISTORTION:	0.001% (1kHz @+4dBu)	0.002% (1kHz @+4dBu)	0.002% (1kHz @+4dBu)

DIGITAL AUDIO PERFORMANCE

PROCESSOR:	40-bit floating point	32-bit (40-bit extended)	40-bit (DX 2006)
SAMPLING RATE:	96kHz	96kHz	96kHz
ANALOG CONVERTERS:	High Performance 24-bit	High Performance 24-bit	High Performance 24-bit
PROPAGATION DELAY:	3.2ms	3ms	1.5ms

FRONT PANEL

DISPLAY:	-	4 x 26 Character Backlit LCD	2 x 16 Character Backlit LCD
LEVEL METERS:	-	5 segment LED	5 segment LED
BUTTONS:	-	Mute/Edit Controls Menu Controls	Mute/Edit Controls Menu Controls
SIGNAL LEADS:	1 per input and output channel	-	-
STATUS LEADS:	Power and network	-	-
DIAL ENCODER:	-	Embedded Thumb Wheel	Embedded Thumb Wheel
CONNECTORS:			
ANALOG INPUTS:	Phoenix 3.5mm (included)	3-pin Female XLR	3-pin Female XLR
DIGITAL I/O	DB25 (AES/EBU)	-	-
ANALOG OUTPUTS:	Phoenix 3.5mm (included)	3-pin Male XLR	3-pin Male XLR
LOGICAL IN-RELAY OUT:	Phoenix 3.5mm (included)	-	-
TCP/IP:	RJ45	-	-
RS-232:	-	Female DB-9 (DX4008)	Female DB-9 (DX4008)
USB:	-	Type B (DX 2006)	Type B (DX 2006)
NETWORK AUDIO I/O:	RJ45 for Dante A, Dante B	-	-
POWER:	Standard IEC Socket	Standard IEC Socket	Standard IEC Socket

GENERAL

POWER:	90-240 VAC (50-60Hz)	90-240 VAC (50-60Hz)	90-240 VAC (50-60Hz)
DIMENSIONS:	19" x 1.75" x 9" (483x44x229mm)	19" x 1.75" x 9" (483x44x229mm)	19" x 1.75" x 9" (483x44x229mm)
WEIGHT:	11 lb - 5 kg	6.1 lb - 3 kg	10 lb - 4.5 kg

MZ

AUDIO MATRIX

MZ 8060

AUDIO MATRIX

MZ 8060 is a highly versatile digital audio matrix designed on a powerful DSP platform, based on advanced electronics.

It features a 8x6 matrix, where 8 universal MIC-LINE inputs and 6 outputs can be processed through a large number of audio parameters, such as parametric equalizers, compressors, gates, limiters, delays, duckers, priorities, auto-mixer.

The Automatic Level Control facility is also available, a probe can be connected on input 8, in order to automatically adjust the volume level according to the environmental noise measured.

Moreover, it is possible to link two MZ 8060 (in master-slave configuration) to create a 16-input 12-output matrix.

A slot on the rear panel allows the integration of an optional RCF RDNet module, to access MZ 8060 through an RDNet control network.

LED indicators to allow the supervision of the audio input and output activities.

A dedicated PC Control Software is available for unit setup and control: a standard USB connector is located on the front panel.

- 40-bit floating point processing DSP and 48 kHz 24-bit HI-Q Analogue/Digital Conversion, dynamic range > 112 dB.
- 8 universal inputs with 48V phantom facility and full audio processing, 6 hi-level routable balanced outputs with full audio processing.
- 10 programmable logic inputs (GPI), 6 programmable logic outputs (GPO), 2 of which supported by relay.
- Configurable parametric EQs, gates, compressors, limiters, delays, priority levels, automatic gain control, levels, gains on in-out and cross points, auto-mixer operations, filters.
- Each unit can work as dual-room combiner with independent auto-mixer facility for each room.
- Configurable ALC (Automatic Level Control) facility by using Input 8 to connect a noise detection microphone. The control is then assignable to any output or group of outputs.
- USB connectivity for device configuration.



TS 9918 p.n. 133.60.235

TOUCH-SENSITIVE REMOTE CONTROL

TS 9918 is a touch sensitive remote control mainly dedicated to MZ 8060 digital mixer preamplifier. Its 8 buttons and scroll-wheel are fully configurable using the PC Control Software and the slim-line structure allows installation in any environment. Three back-light operation modes are available according to application: night, eco, daylight.



SPECIFICATIONS

MZ 8060

p.n. 171.00.004

A/D – D/A CONVERTERS	24 bits
SAMPLING RATE:	48 kHz
MAX. AUDIO INPUT LEVEL	+24 dBu (balanced)
MAX. MIC INPUT GAIN	+50 dB
OUTPUT IMPEDANCE	50 Ω
FREQUENCY RESPONSE	20 Hz ÷ 20 kHz (±0.5 dB)
DYNAMIC RANGE	> 114 dB
DISTORTION (THD+N, 1kHz@ +22 dBu):	< 0.01% (analogue input to analogue output)
POWER:	100 ÷ 240 V ac (50 / 60 Hz)
PHANTOM POWER:	48 V
DIMENSIONS (W x H x D):	482 x 44 x 320 mm (1 unit - 19" rack) (18.98" x 1.73" x 12.60")
NET WEIGHT	3.475 kg (7.66 lbs)

APPLICATIONS

- Fixed installations
- Meeting rooms
- Houses of worship
- Restaurants
- Bars
- Court rooms

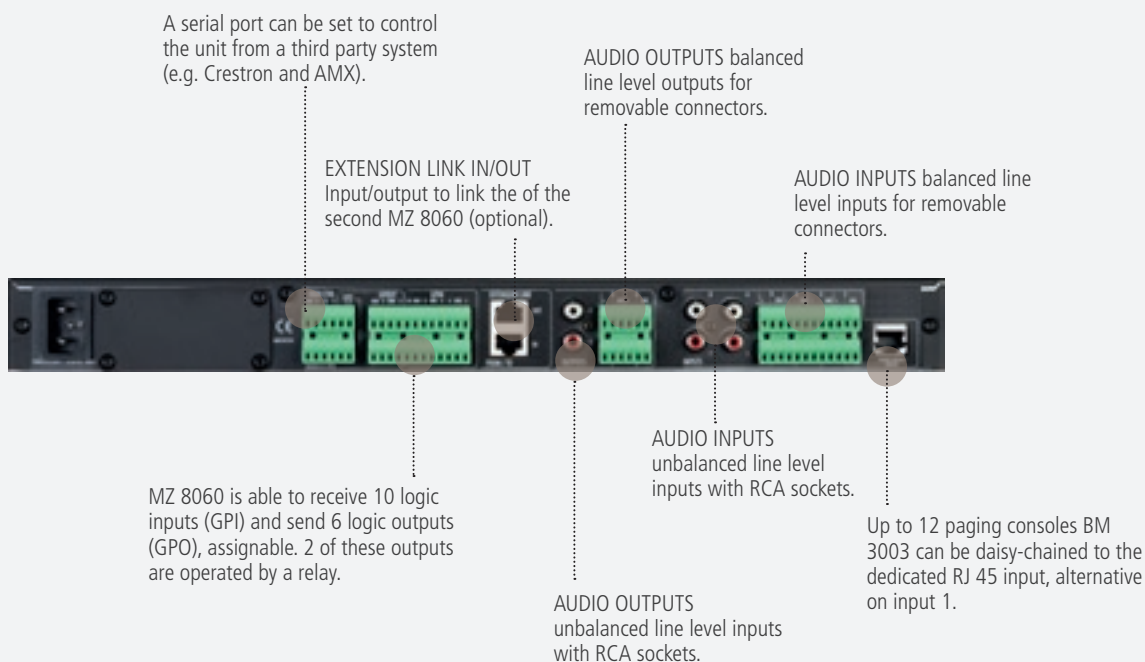

1033

AUDIO SOURCE

MS 1033

CD-USB MP3 PLAYER WITH FM RADIO TUNER

The MS 1033 is really a dual sound source, built on two independent sections that can be used at the same time.

CD player with anti-shock mechanism and electronics. It plays both audio tracks and MP3 files on compact discs (CD, CD-R, CD-R/W). It plays MP3 files (only) on USB flash drives and 'Secure Digital' (SD) cards (this port is also compatible for 'MultiMedia Cards').

Tuner (FM: 87.5 ÷ 108 MHz) with 60 memories (10 accessed directly and 50 through the remote control) to store and recall preferred stations quickly.

- Double sound source with two independent sections and outputs (Tuner - CD/MP3)
- CD player to reproduce audio tracks and MP3 files from a compact disc (CD, CD-R, CD-R/W) or from the USB drive ("Flash" memory-stick with only MP3 files)
- The USB port is available on both front and back panels to provide maximum flexibility
- The SD card port is available on front panels
- I/R remote control for CD and Tuner included
- LCD backlit display gives information on the CD and MP3 files
- FM radio tuner (87.5 - 108 MHz) with possibility to memorize your 30 favourite radio stations
- Stereo / Mono selector for applications where stereo signals are not needed
- LCD backlit display shows the frequency and stations that are in the memory

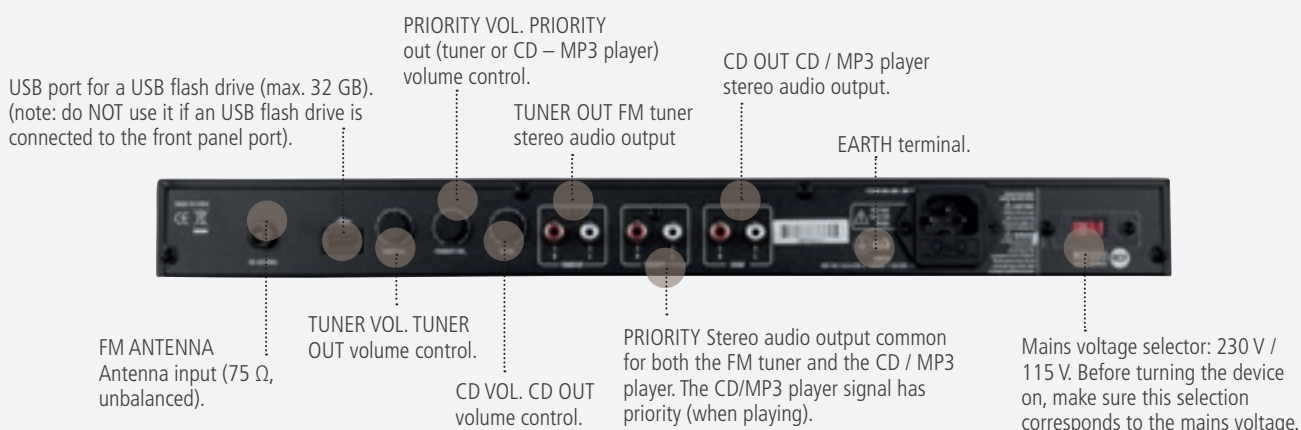



SPECIFICATIONS

MS 1033

p.n. 171.70.108

AMPLIFIER SPECIFICATIONS

FREQUENCY RESPONSE (-3DB):	20 Hz ÷ 20 kHz
SIGNAL/NOISE RATE ("A" WEIGHTED)	>80 dB dB
CROSSTALK	<60 dB dB
DISTORTION (THD+N) @ 1 KHZ NOMINAL POWER:	<0.15 %%
PROTECTIONS:	Cooling (Convection)

OUTPUT SECTION

SIGNAL OUTPUT NUMBER:	3
SIGNAL OUTPUT CONNECTORS:	RCA

CONTROLS

CONFIGURATION:	Front panel
PRIORITY:	Yes

AUDIO SOURCES

AUDIO SOURCES:	CD, FM Tuner, USB pen drives, SD card:
----------------	--

GENERAL

OPERATING VOLTAGE:	220-240/115 V~ 50/60HzV ~ Hz
VOLTAGE SELECTION:	External
POWER CONSUMPTION:	50 W
CABINET/CASE MATERIAL:	Metal
COLOR:	Black
RACK MOUNTING:	19", 1U
DIMENSIONS: H x W x D	1.73" x 18.98" x 9.84" (44 x 482 x 250 mm)
WEIGHT:	8.16 lb - 3.7 kg

APPLICATIONS

- Restaurants
- Boutique
- Pub
- Beauty Centre
- Market
- Fitness Centre / Gym
- Dentist's surgery

ACCESSORIES

UNIVERSAL ACCESSORIES FOR LOUDSPEAKERS

RCF offers a complete range of universal high quality accessories for loudspeakers.



AC S260

Steel speaker floor stand with folding base and telescopic rod, tube diameter 35mm. - Equipped with damping system and safety plug; central die-cast joint - Load capacity up to 60 kg - Weight 7,8 kg - H MIN/MAX 170 cm / 240 cm - Max base opening 130 cm diameter - Length once folded 123 cm.

p.n. 133.60.035



AC S140

Aluminium speaker floor stand with folding base and telescopic rod, tube diameter 35mm. - Equipped with damping system and safety plug - Load capacity up to 40 kg - Weight 2,7 kg - H MIN/MAX 140 cm / 214 cm - Max base opening 130 cm diameter - Length once folded 107 cm.

p.n. 133.60.036



AC PMA

Aluminium pole mount stand with telescopic rod, tube diameter 35 mm. - Load capacity up to 40 kg

p.n. 133.60.034



AC EB 4X

Set of four eye bolts

p.n. 133.60.031



AC NL4F 4X

Kit including No. 4 Neutrik Speakon NL4F connectors.

p.n. 133.60.033



AC PRO-FS

Steel speaker floor stand with folding base and telescopic rod, tube diameter 35mm. Load capacity up to 50 kg, Weight 4.5 kg, H MIN/MAX 137 cm / 210 cm. Length once folded 102 cm

p.n. 133.60.109



AC PRO-LF

Steel professional adapter sleeve for loudspeaker floor stands, tube diameter 35 mm. Load capacity up to 50 kg, Weight 0.7 kg, H 275 cm.

p.n. 133.60.111



AC PRO-PM

Steel pole mount accessory for a satellite loudspeaker on a subwoofer, tube diameter 35 mm. Load capacity up to 35 kg, Weight 2.4 kg, H MIN/MAX 95 cm / 137 cm.

[p.n. 133.60.110](#)



AC XLR-3M3F

3 XLR Female connector with nickel body and silver contacts. 3 XLR Male connector with nickel body and silver contacts.

[p.n. 133.60.102](#)



AC PMA TT

Pole mount cap for TTS18, TTS 18-A, TTS 28 and TTS 28-A subwoofer.

[p.n. 133.60.068](#)



AC PMX

Speaker pole mount with pushbutton system and hand crank to avoid uncontrolled reverse motion. Locking screw provides additional safety.

[p.n. 133.60.232](#)



CVR ART 312

Protection cover for all ART 315 and Art 312.

[p.n. 133.60.043](#)



CVR ART 310

Protection cover for ART 310.

[p.n. 133.60.044](#)



CVR ART 725

Protection cover for ART 725. Protects the speaker from scratches and hits. Strong nylon construction.

[p.n. 133.60.115](#)

ACCESSORIES

UNIVERSAL LINE TRANSFORMERS

High quality transformers suitable to connect loudspeakers with 4-8 Ω impedance to constant voltage lines (70-100V). It's possible to select different power values. Thanks to material over-sizing and alternate layer windings, they offer high performance: dynamics and frequency response are particularly extended. They are suitable to drive professional speakers through constant voltage power amplifiers.



TD 10

p.n. 133.60.045

OUTPUT POWER 4 Ω	1.2 - 2.5 - 5 - 10 W
OUTPUT POWER 8 Ω	0.6 - 1.2 - 2.5 - 5 - 10 W
FREQUENCY RESPONSE	50 ÷ 18.000 Hz
DIMENSIONS	86 x 53 x 59 mm
WEIGHT	0.5 kg



TD 30

p.n. 133.60.046

OUTPUT POWER 4 Ω	15 - 30 W
OUTPUT POWER 8 Ω	7.5 - 15 - 30 W
FREQUENCY RESPONSE	50 ÷ 18.000 Hz
DIMENSIONS	87 x 53 x 68 mm
WEIGHT	0.74 kg



TD 60

p.n. 133.60.047

OUTPUT POWER 4 Ω	15 - 30 - 60 W
OUTPUT POWER 8 Ω	7.5 - 15 - 30 - 60 W
FREQUENCY RESPONSE	50 ÷ 18.000 Hz
DIMENSIONS	77 x 77 x 79 mm
WEIGHT	1.22 kg



TD 120

p.n. 133.60.048

OUTPUT POWER 4 Ω	30 - 60 - 120 W
OUTPUT POWER 8 Ω	15 - 30 - 60 - 120 W
FREQUENCY RESPONSE	50 ÷ 18.000 Hz
DIMENSIONS	85 x 85 x 90 mm
WEIGHT	1.87 kg



TD 240

p.n. 133.60.049

OUTPUT POWER 4 Ω	60 - 120 - 240 W
OUTPUT POWER 8 Ω	30 - 60 - 120 - 240 W
FREQUENCY RESPONSE	50 ÷ 18.000 Hz
DIMENSIONS	98 x 89 x 100 mm
WEIGHT	3.1 kg

ACCESSORIES FOR VSA II



IT 4000

INPUT TRANSFORMER 100V TO 0 DB

IT 4000 is an accessory that consists of a transformer that allows the connection of a 100V (or 70V) passive speakers line directly to the audio input (0 dBu) of an active speaker.

p.n. 133.60.341



TA1000 VSA

100V TRANSFORMER FOR VSA ACTIVE SPEAKERS

TA 1000 is an accessory that consists of a small printed circuit board with a transformer that allows the connection of a 100 V line (amplifier output) directly to the aux audio input (0 dBu) of an active speaker.

p.n. 133.60.318



www.rcf.it

HEADQUARTERS:

RCF S.p.A. Italy
tel. +39 0522 274 411
e-mail: info@rcf.it

RCF UK
Int. +44 (0) 1702 800846
e-mail: info@rcfaudio.co.uk

RCF France
tel. +33 6 24 15 81 76
e-mail: france@rcf.it

RCF Germany
tel. +49 2203 925370
e-mail: germany@rcf.it

RCF Spain
tel. +34 91 817 42 66
e-mail: info@rcfaudio.es

RCF Benelux
tel. +49 (0) 2203 9253724
e-mail: benelux@rcf.it

RCF USA Inc.
tel. +1 732-9026100
e-mail: info@rcf-usa.com